

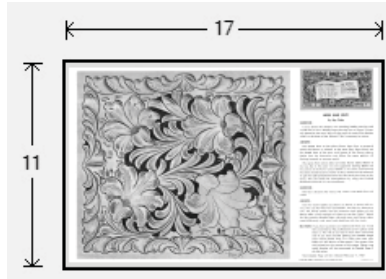

## Doodle Page Digital Download

This PDF file contains 1 (one) Doodle Page. The PDF has been put together to give you options when it comes to printing. Pages and patterns that are larger than 8½x11 have been provided in two formats:



### 1) Full Size

If you would like to have a full size print out, take the full size pages to your local print shop and they can print it for you. All full size Doodle Pages are 11x17

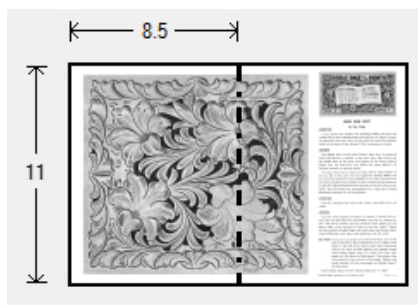

### 2) Tiled

The tiled pages give you the option of printing the full sized Doodle Pages at home. You print the tiled pages and then assemble them to make the larger patterns.

The Doodle Page PDF files are typically laid out like this:

Front – full sized, front – tiled, back – full sized, back – tiled

(Some Doodle Pages do not have backs)

Please note: When printing on a home printer, the edges may get cut off. To avoid this, make sure “Page Scaling” is set to “Shrink to Printable Area” in the Adobe Reader print dialogue box. This will decrease the size of the Doodle Page a very small amount.

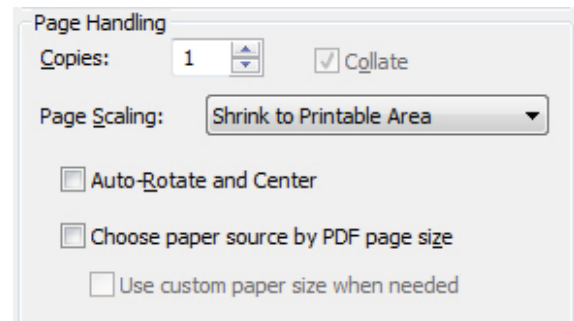

You may take this PDF file to your local print shop to have the full-size pages printed for your own personal use.



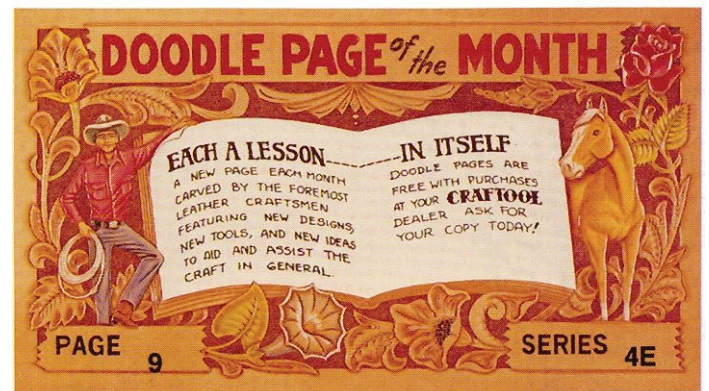
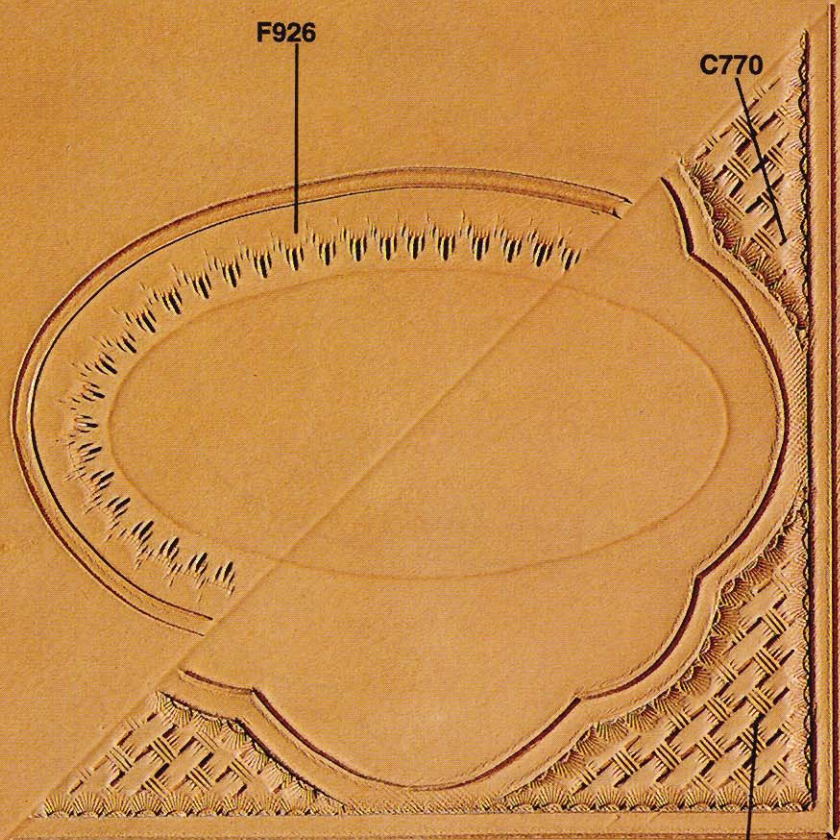
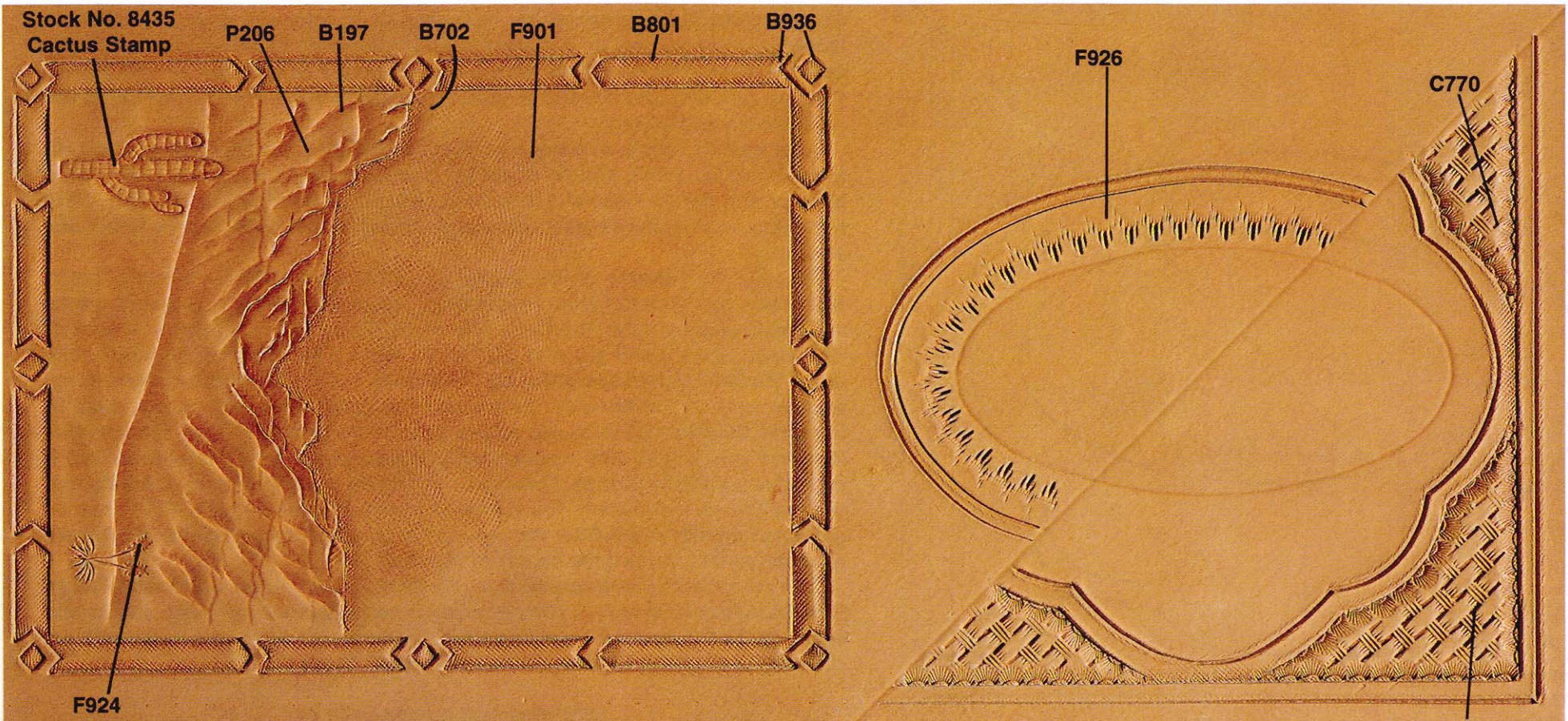

# Tissue Box Cover

(for cube shaped Dispenser)  
By Harold Arnett and Jana Zettl

This is the first in our series of home and office decor projects. Actual box cover should be cut from 4/5 oz. tooling leather. Follow the cutting pattern shown. Punch all of the lacing holes and cut the oval dispensing hole. After cutting out the shape, rubber cement the piece, flesh side down, to heavy paper or stiff cardboard. This prevents stretching and causes your tooling to take on a darker burnish.

Sample A : The basketweave/floral pattern is the more traditional of the two designs. It requires the following tools: F976, C830, P213, P975, C770, X500, B702, A104, P236, C828, V462, B701, and a swivel knife. You will also need tracing film, a ball point stylus, and a soft lead pencil for tracing. Depending on the lacing or stitching that you choose, you will need a 3/64" hole punch, and a V-Gouge No. 8082. You may also want some "Lexol" conditioner. When wetting my leather I use a spray bottle, and I always add some Lexol to the water. It makes your swivel knife cut more easily, makes natural leather turn a prettier color with age, and adds oils back to the leather that repeated wetting pulls out.

Cut out your leather shape, trace your pattern, and transfer to the leather. Jana and I used a full cover basketweave on 2 opposite sides and the framed basketweave/floral, as shown, on the other two sides. If you are a novice, refer to Al Stohlman's book "How To Carve Leather" Stock No. 6047, for tooling tips. The natural colored leather of the finished samples, as seen in the inset, had two coats of Super Shene® applied before the entire project was antiqued. We used Tandy's Mahogany Antique and finished with spray Saddle-Lac. After the finish was completely dry, we peeled the leather off of the backing and cut a groove along the flesh side of the top, all the way around the edges, where it was going to fold. After gouging, we lightly dampened the flesh side, to aid in forming the folds. Then, we used a Mexican Basketweave lace (10 yds. of 3/32" calf #5004) technique, as seen in, "Leather Braiding" Stock No. 1931, to finish the corners.

Sample B: The Southwest design, with skulls, may be painted in any combination of colors to compliment any interior. With the continuing interest in Southwest decor, we wanted something that could go in the office, the den or even the bathroom. Try to stay with muted colors to go with the Southwest theme, even though all of the panels are the same, we added the skulls (Stock No. 1529 Bolo Slide) and painted each one differently to give all of the sides a distinct look.

This pattern required these tools: F901, B801, B197, B936, B702, P206, F926, F924, Cactus stamp Stock No. 8435, Stylus Stock No. 7059, Swivel Knife, Needle-nose pliers, tracing film, a pencil, V-Gouge Stock No. 8082, a 3/64" hole punch, and a Stylus. Again, refer to the book "How To Carve Leather", if you need tooling help or just jump into it. After tooling, paint with Tandy's Cova

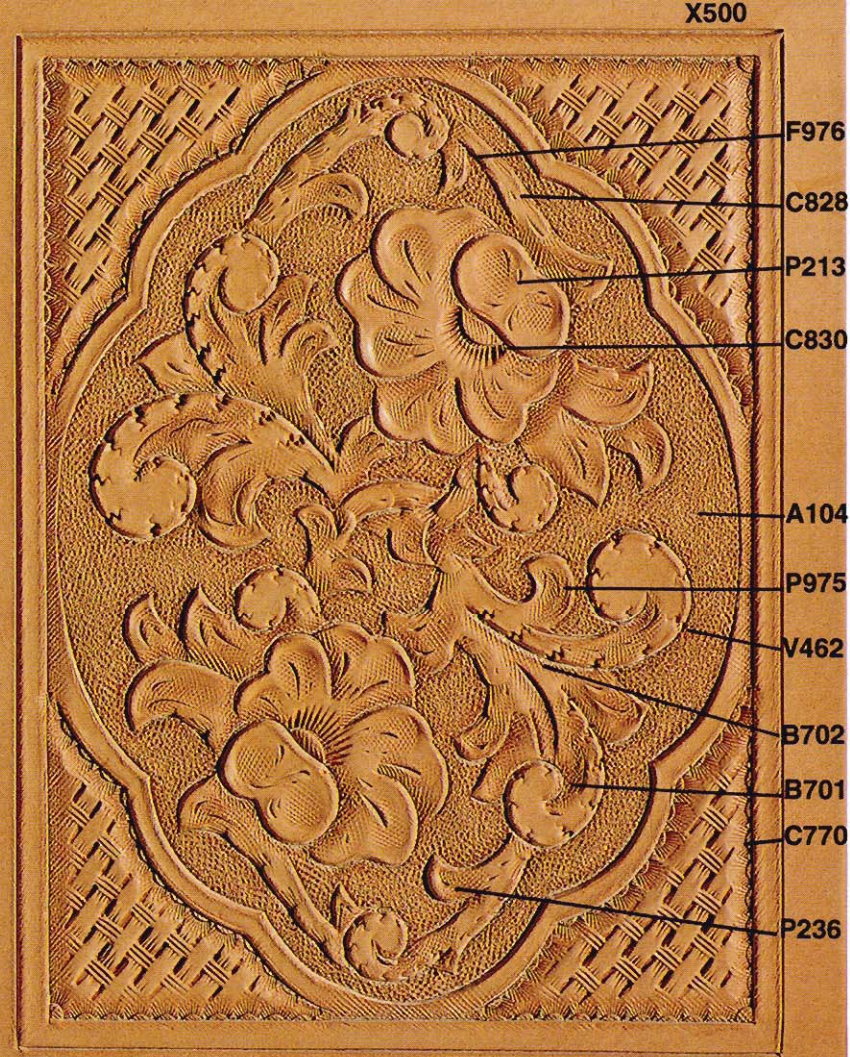



Stock No. 8435  
Cactus Stamp

P206

B197

B702

F901

B801

B936

F926

F924

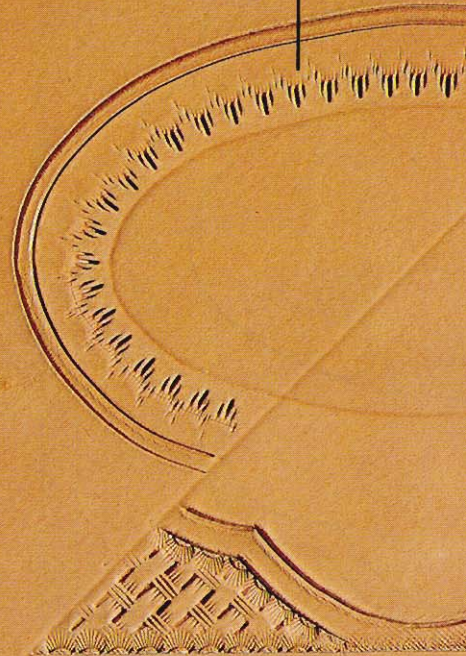



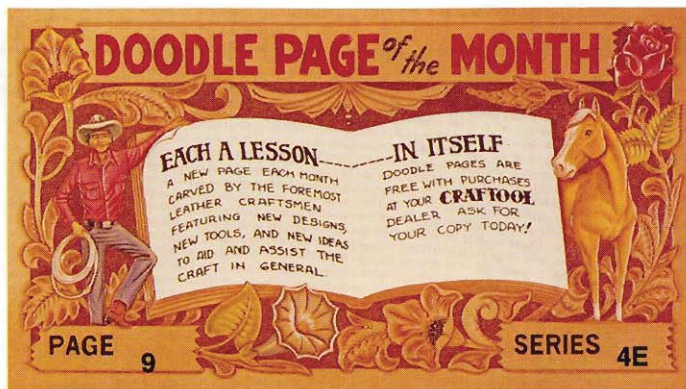
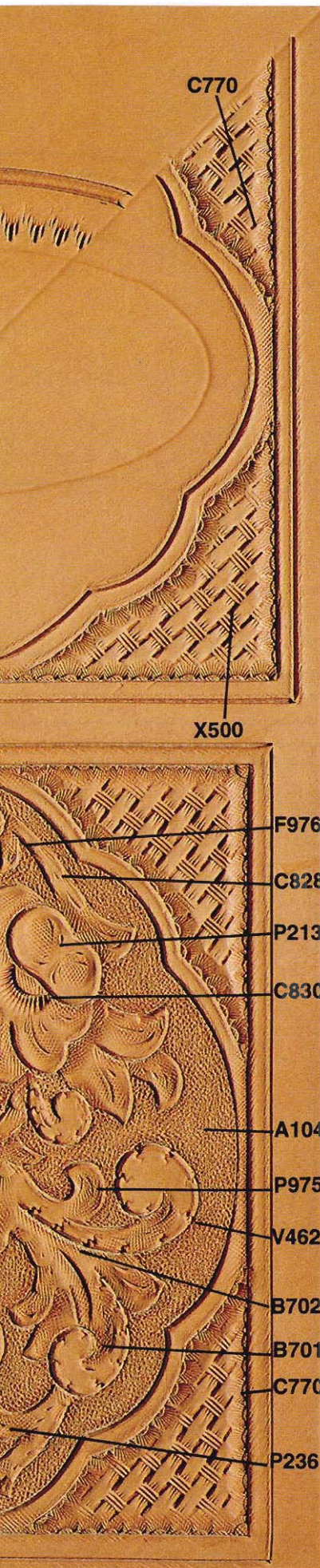

## Tissue Box Cover

(for cube shaped Dispenser)  
By Harold Arnett and Jana Zettl

This is the first in our series of home and office decor projects. Actual box cover should be cut from 4/5 oz. tooling leather. Follow the cutting pattern shown. Punch all of the lacing holes and cut the oval dispensing hole. After cutting out the shape, rubber cement the piece, flesh side down, to heavy paper or stiff cardboard. This prevents stretching and causes your tooling to take on a darker burnish.

Sample A : The basketweave/floral pattern is the more traditional of the two designs. It requires the following tools: F976, C830, P213, P975, C770, X500, B702, A104, P236, C828, V462, B701, and a swivel knife. You will also need tracing film, a ball point stylus, and a soft lead pencil for tracing. Depending on the lacing or stitching that you choose, you will need a 3/64" hole punch, and a V-Gouge No. 8082. You may also want some "Lexol" conditioner. When wetting my leather I use a spray bottle, and I always add some Lexol to the water. It makes your swivel knife cut more easily, makes natural leather turn a prettier color with age, and adds oils back to the leather that repeated wetting pulls out.

Cut out your leather shape, trace your pattern, and transfer to the leather. Jana and I used a full cover basketweave on 2 opposite sides and the framed basketweave/floral, as shown, on the other two sides. If you are a novice, refer to Al Stohlman's book "How To Carve Leather" Stock No. 6047, for tooling tips. The natural colored leather of the finished samples, as seen in the inset, had two coats of Super Shene® applied before the entire project was antiqued. We used Tandy's Mahogany Antique and finished with spray Saddle-Lac. After the finish was completely dry, we peeled the leather off of the backing and cut a groove along the flesh side of the top, all the way around the edges, where it was going to fold. After gouging, we lightly dampened the flesh side, to aid in forming the folds. Then, we used a Mexican Basketweave lace (10 yds. of 3/32" calf #5004) technique, as seen in, "Leather Braiding" Stock No. 1931, to finish the corners.

Sample B: The Southwest design, with skulls, may be painted in any combination of colors to compliment any interior. With the continuing interest in Southwest decor, we wanted something that could go in the office, the den or even the bathroom. Try to stay with muted colors to go with the Southwest theme, even though all of the panels are the same, we added the skulls (Stock No. 1529 Bolo Slide) and painted each one differently to give all of the sides a distinct look.

This pattern required these tools: F901, B801, B197, B936, B702, P206, F926, F924, Cactus stamp Stock No. 8435, Stylus Stock No. 7059, Swivel Knife, Needlenose pliers, tracing film, a pencil, V-Gouge Stock No. 8082, a 3/64" hole punch, and a Stylus. Again, refer to the book "How To Carve Leather", if you need tooling help or just jump into it. After tooling, paint with Tandy's Cova



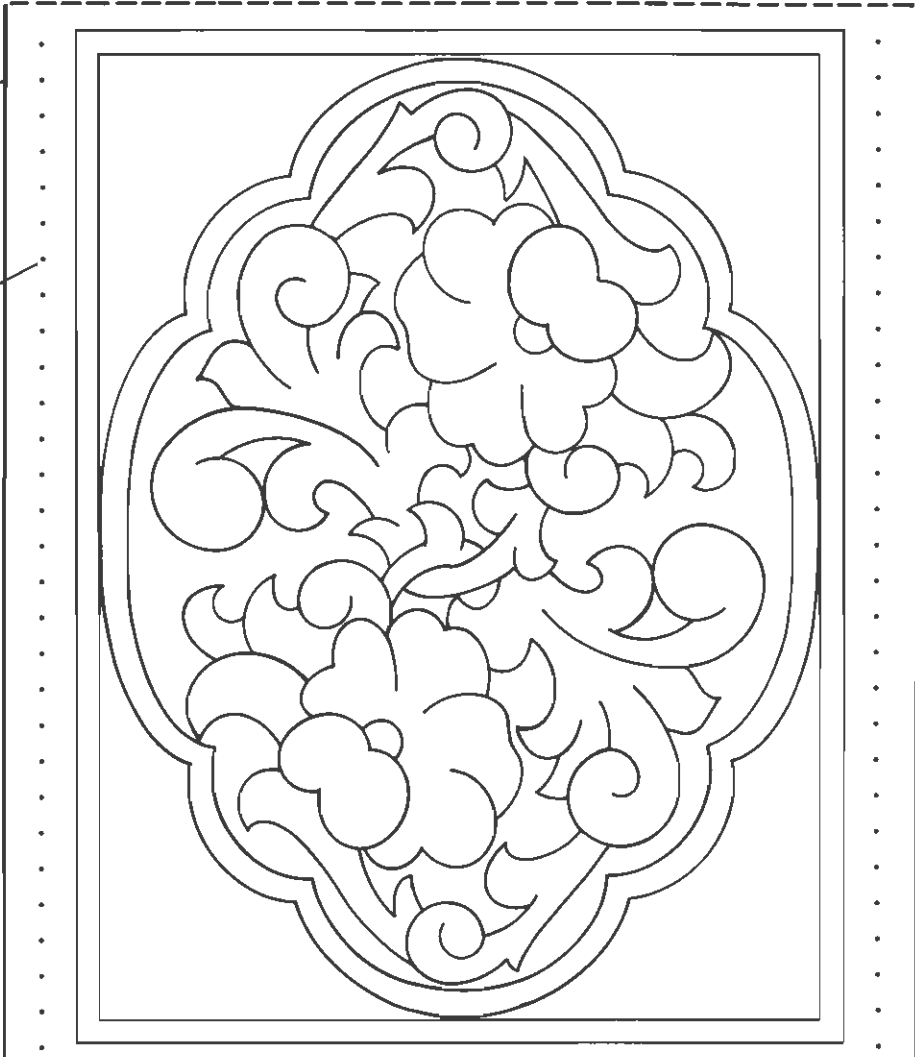
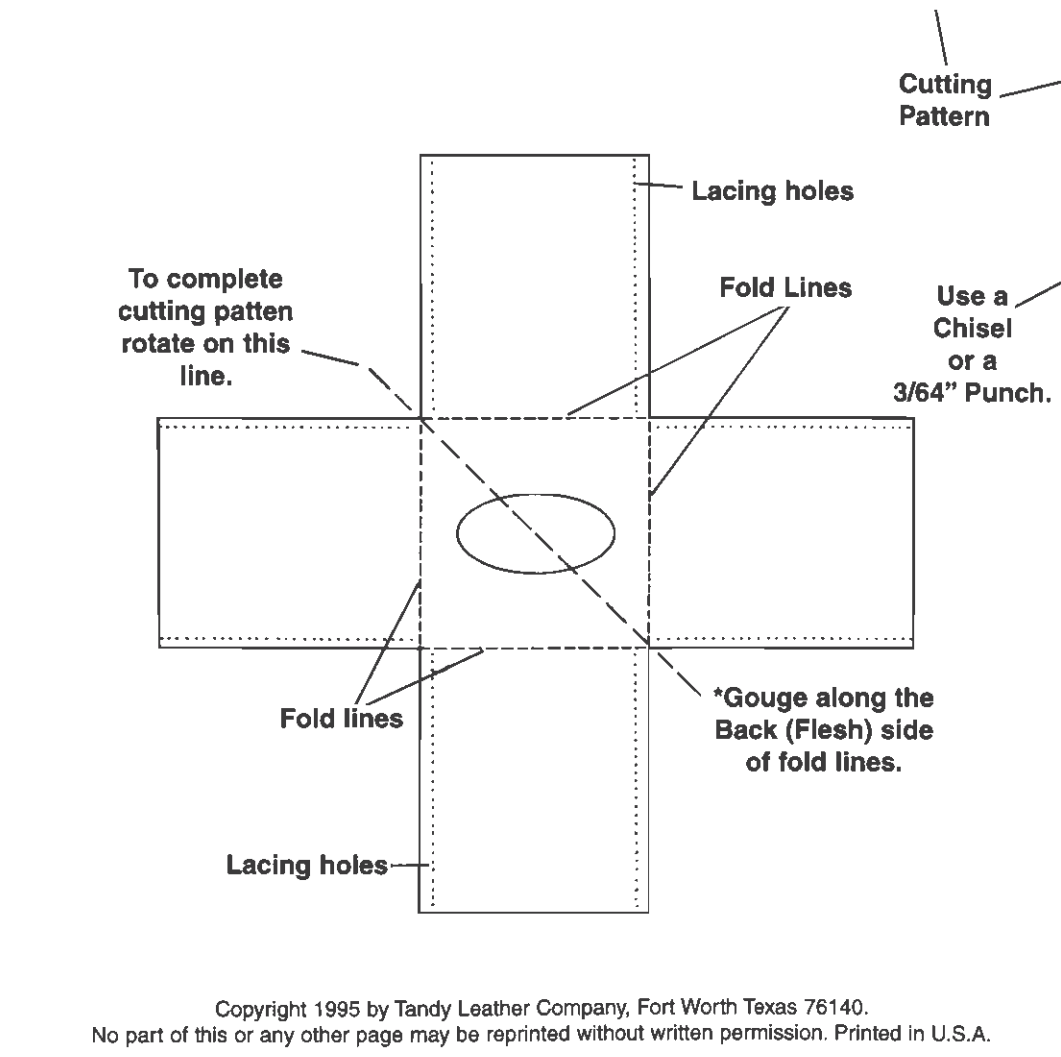
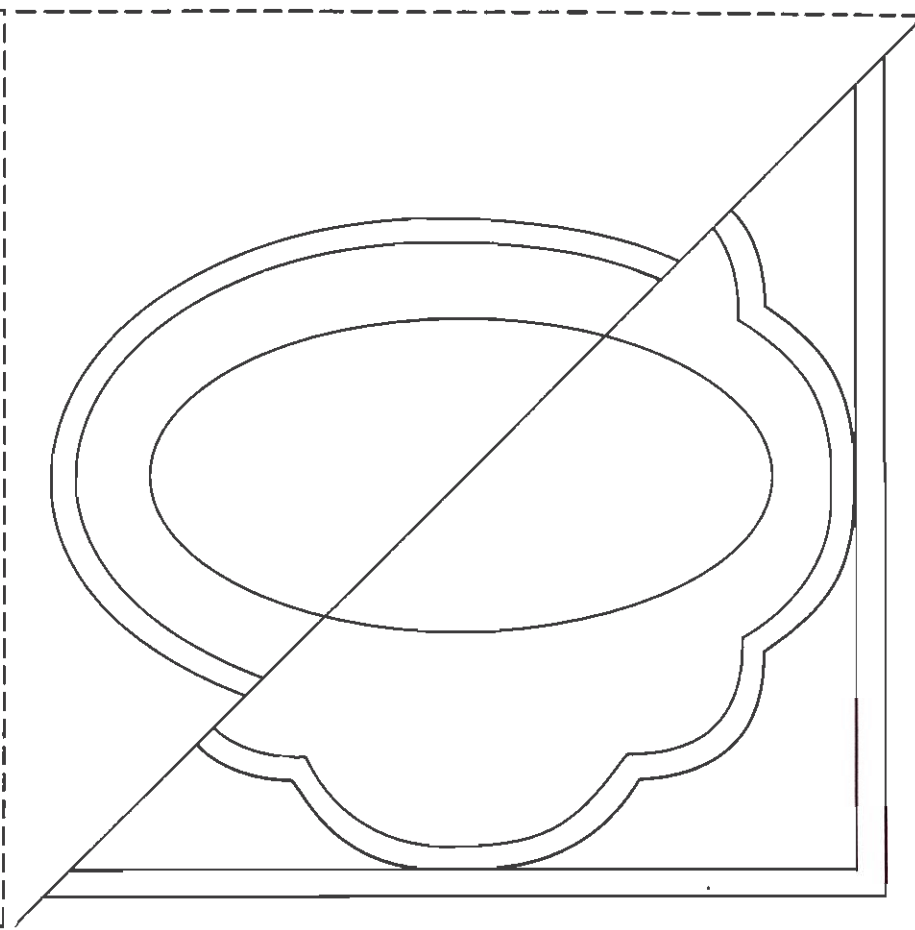
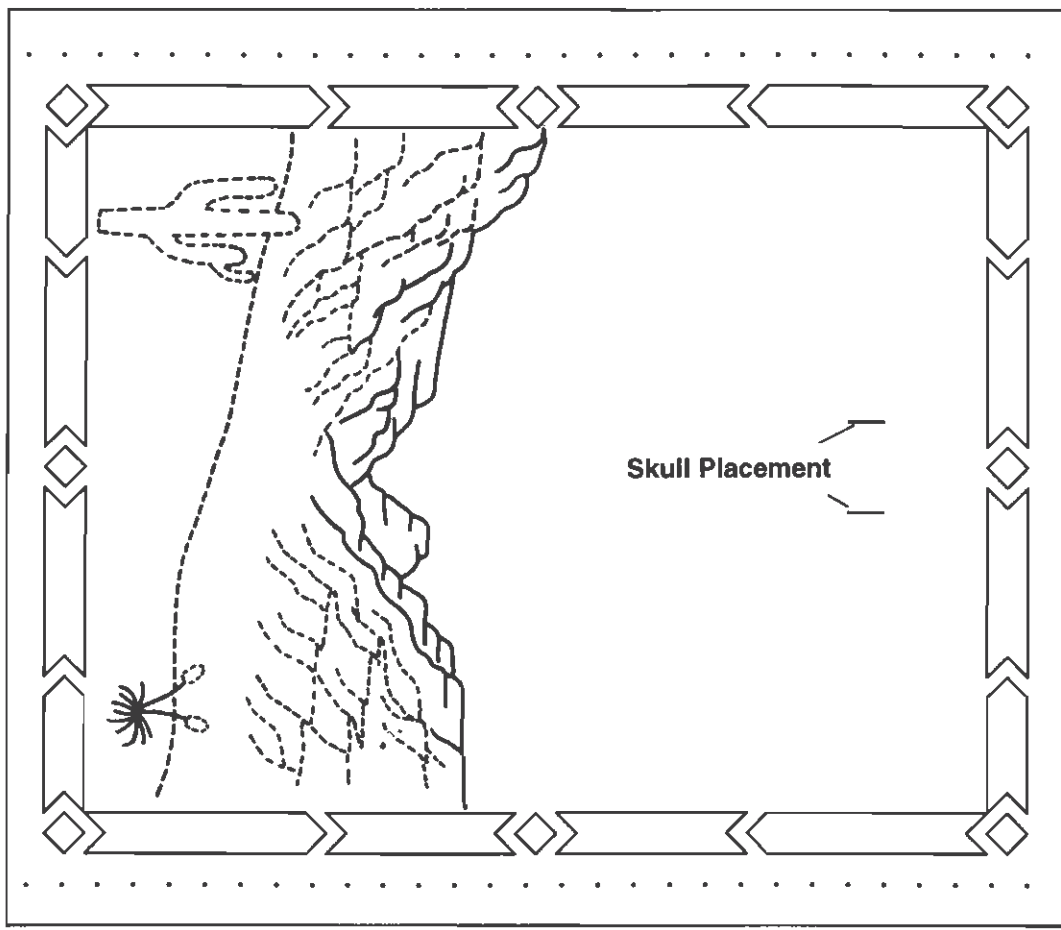

Color®. Cova Color is known for its brilliance of color and covering ability. In this case, however, we do not want to take advantage of these qualities. Every color that we used we diluted with water at about a 50/50 mix. The more water that you mix with, the more of a color wash you achieve. This is how to get the nice transparent colors.

After painting apply a heavy coat of spray Saddle-Lac, allow to dry. Apply Hi-Liter Stock No. 2042, and let it set for about 30 seconds. Use a clean damp sponge and gently remove the excess Hi-Liter using a circular motion. After removing most of the excess, use a paper towel in the same manner to remove streaks.

To paint the patterns on the skulls, use the Cova Color full strength. This is where you can express your imagination. These may be very simple or somewhat extravagant. After the Cova has dried (20 to 30 mins.) spray a coat of Saddle-Lac over it and allow to dry. Gently apply a thin coat of Hi-Liter to tone down the skull colors and enhance the lines in the skull. After that dries, spray another coat of Saddle-Lac. You are ready to prepare the back of the skull to attach to the box. The Bolo clip on the back of the skull is a piece of brass that is rolled into shape. Use needlenose pliers to unroll the Bolo clip so that it makes two straight prongs. These prongs will be pushed through the slits that are marked on the pattern. You will need to cut or chisel these slits in order to get the prongs through. After the prongs are punched through, bend them down against the box, toward the center of the skull.

Now you're ready to assemble the box. On our sample Jana and I used, "Night Glo" Stock No. 3903 lace (4 yds.) because it had a rawhide look, was subtle, and even makes the tissues easy to find in the dark. For Whipstitch instructions, refer to "Lacing and Stitching for Leathercraft" Stock No. 1906.

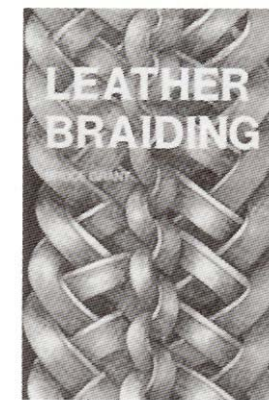

**Leather Braiding**  
Braid like a pro! Learn to braid bridles, belts, hat-bands, cane handles and more. Includes glossary. 192 pages. **Stock No. 1931**

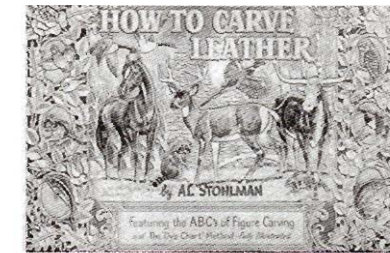

**How To Carve Leather**  
Shows the basics of carving. Over 60 patterns for billfolds, belts, and more. Alternate figures, scrolls, flowers. 48 pages. **Stock No. 6047**



**Lacing and Stitching for Leathercraft.**  
Shows 10 lacing and stitching techniques. Tips on splicing, hole punching, needle threading. 22 pages. **Stock No. 1906**



Distributed by Tandy Leather Co.  
Fort Worth, Texas 76140.

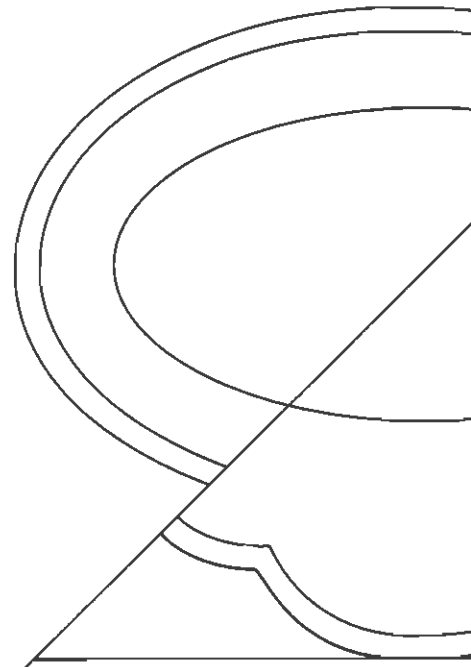
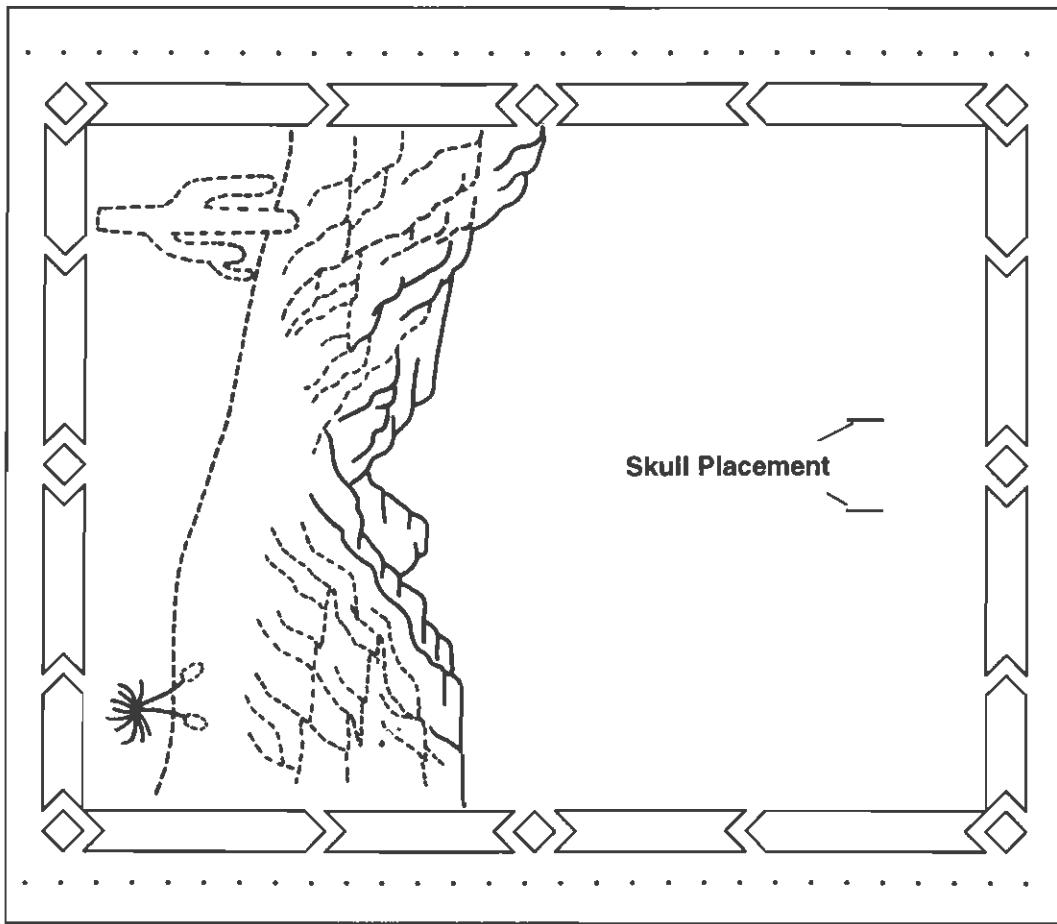

To complete cutting patten rotate on this line.

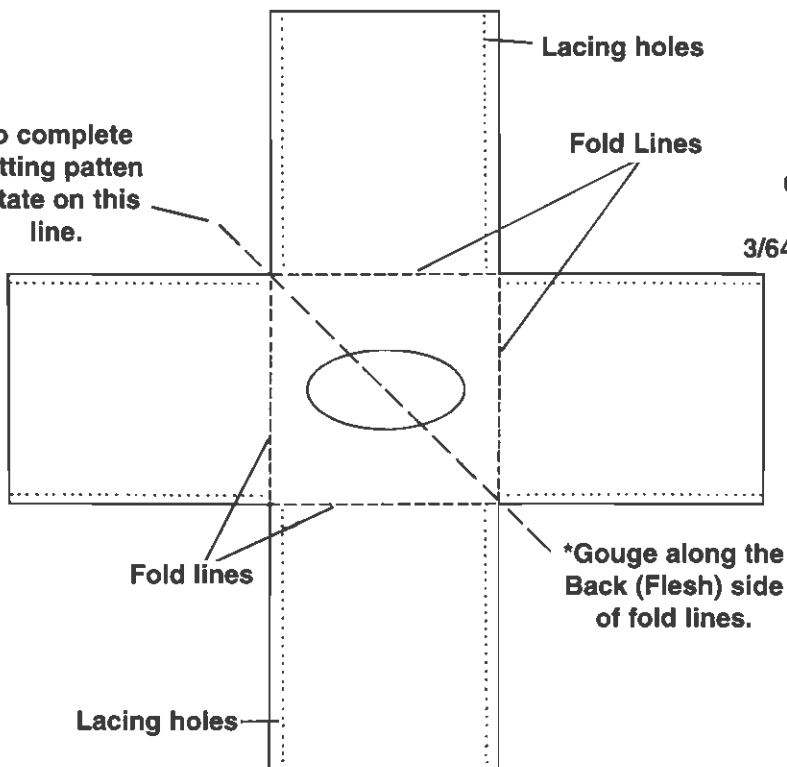

Cutting Patten

Use a Chisel or a 3/64" Punch.

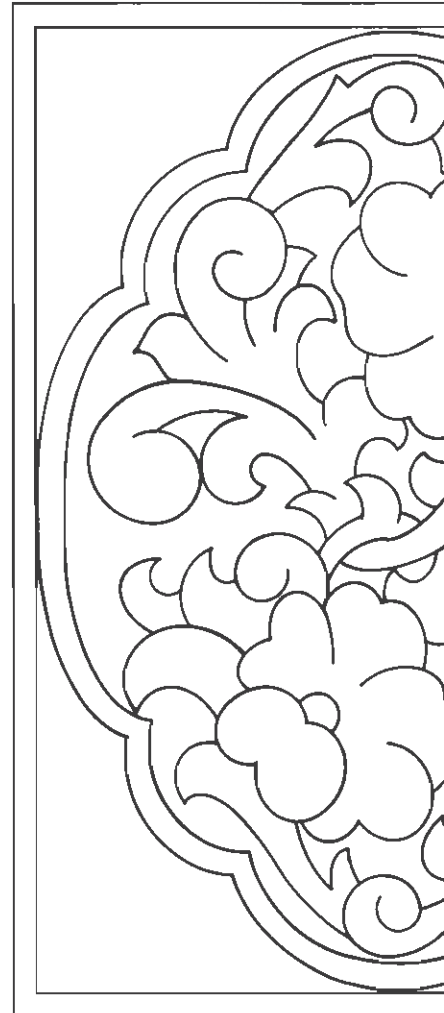

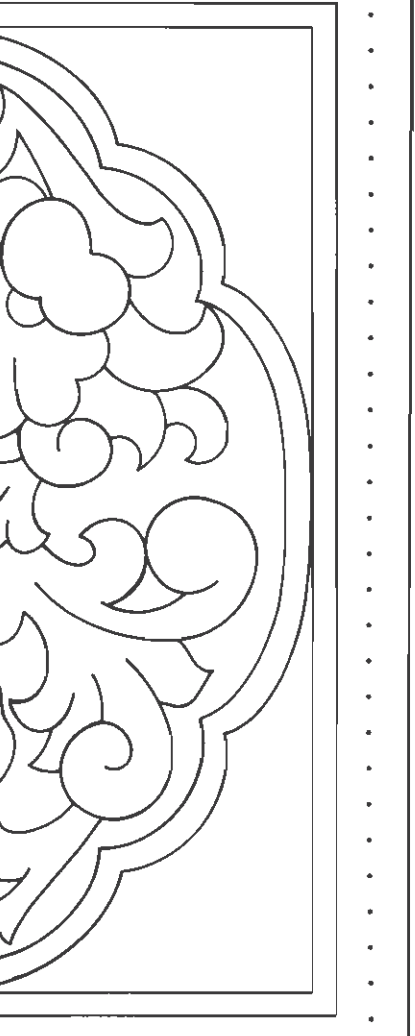
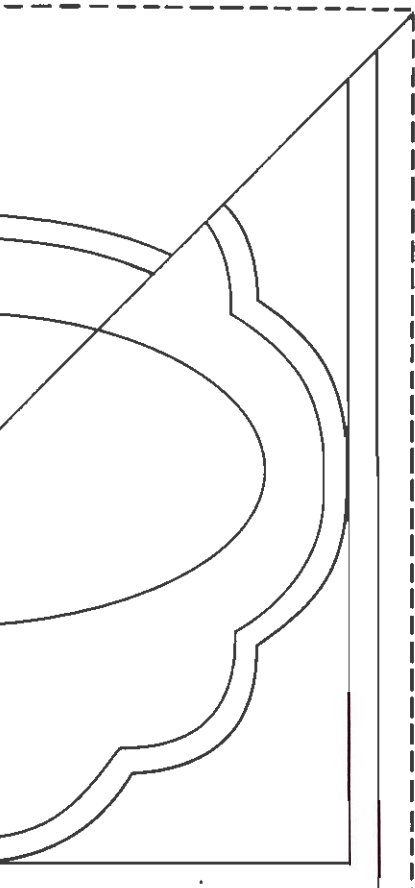

Color®. Cova Color is known for its brilliance of color and covering ability. In this case, however, we do not want to take advantage of these qualities. Every color that we used we diluted with water at about a 50/50 mix. The more water that you mix with, the more of a color wash you achieve. This is how to get the nice transparent colors.

After painting apply a heavy coat of spray Saddle-Lac, allow to dry. Apply Hi-Liter Stock No. 2042, and let it set for about 30 seconds. Use a clean damp sponge and gently remove the excess Hi-Liter using a circular motion. After removing most of the excess, use a paper towel in the same manner to remove streaks.

To paint the patterns on the skulls, use the Cova Color full strength. This is where you can express your imagination. These may be very simple or somewhat extravagant. After the Cova has dried (20 to 30 mins.) spray a coat of Saddle-Lac over it and allow to dry. Gently apply a thin coat of Hi-Liter to tone down the skull colors and enhance the lines in the skull. After that dries, spray another coat of Saddle-Lac. You are ready to prepare the back of the skull to attach to the box. The Bolo clip on the back of the skull is a piece of brass that is rolled into shape. Use needle-nose pliers to unroll the Bolo clip so that it makes two straight prongs. These prongs will be pushed through the slits that are marked on the pattern. You will need to cut or chisel these slits in order to get the prongs through. After the prongs are punched through, bend them down against the box, toward the center of the skull.

Now you're ready to assemble the box. On our sample Jana and I used, "Night Glo" Stock No. 3903 lace (4 yds.) because it had a rawhide look, was subtle, and even makes the tissues easy to find in the dark. For Whipstitch instructions, refer to "Lacing and Stitching for Leathercraft" Stock No. 1906.

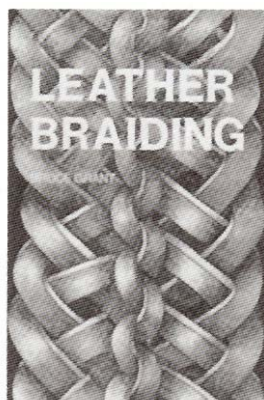

**Leather Braiding**  
Braid like a pro! Learn to braid bridles, belts, hatbands, cane handles and more. Includes glossary. 192 pages. **Stock No. 1931**



**How To Carve Leather**  
Shows the basics of carving. Over 60 patterns for billfolds, belts, and more. Alternate figures, scrolls, flowers. 48 pages. **Stock No. 6047**



**Lacing and Stitching for Leathercraft.**  
Shows 10 lacing and stitching techniques. Tips on splicing, hole punching, needle threading. 22 pages. **Stock No. 1906**



Distributed by Tandy Leather Co.  
Fort Worth, Texas 76140.