



Doodle Page Digital Download

This PDF file contains 1 (one) Doodle Page. The PDF has been put together to give you options when it comes to printing. Pages and patterns that are larger than 8½x11 have been provided in two formats:



1) Full Size

If you would like to have a full size print out, take the full size pages to your local print shop and they can print it for you. All full size Doodle Pages are 11x17



2) Tiled

The tiled pages give you the option of printing the full sized Doodle Pages at home. You print the tiled pages and then assemble them to make the larger patterns.

The Doodle Page PDF files are typically laid out like this:

Front – full sized, front – tiled, back – full sized, back – tiled

(Some Doodle Pages do not have backs)

Please note: When printing on a home printer, the edges may get cut off. To avoid this, make sure “Page Scaling” is set to “Shrink to Printable Area” in the Adobe Reader print dialogue box. This will decrease the size of the Doodle Page a very small amount.



You may take this PDF file to your local print shop to have the full-size pages printed for your own personal use.

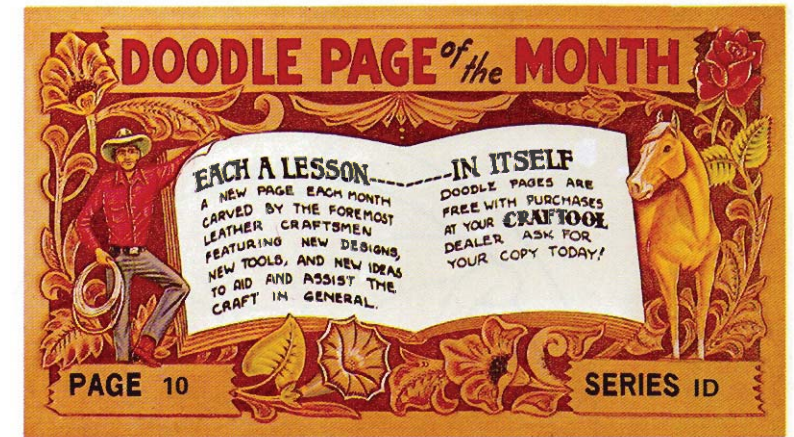

"ROUNDER BUCKLES"

by DAN NOLAND

These Rounder Buckle designs were designed in a modernistic and ecologicistic way. I have made other belt buckle designs, and I've seen Dad make some, but I was tooling some Rounders for coasters and thought these would make good buckles. You just carve one (#3) and put a buckle back ring and hook (#1) and the other (#2) and then glue them together with Craftsman cement. You can even lace them together if you want to.

Dad helped me a little on the layout of these designs and I am sure you can think of other designs for your own Rounders. I just hope these will give you the idea on how to make them.

After I did all the carving I colored them with Cova Dye. You may wish to use different colors than what I did or just make natural ones without color.

I am studying Drafting and Design at our Vo-Tech school and hope it will help me do other designs in the future.

I hope you like these designs that I've done and Good Luck in your Leather Carving.

Photo Carve Patterns

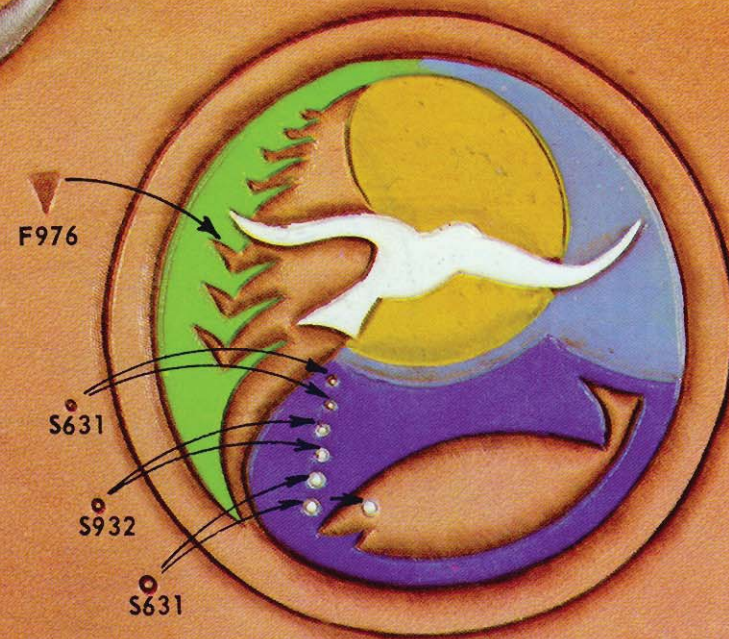
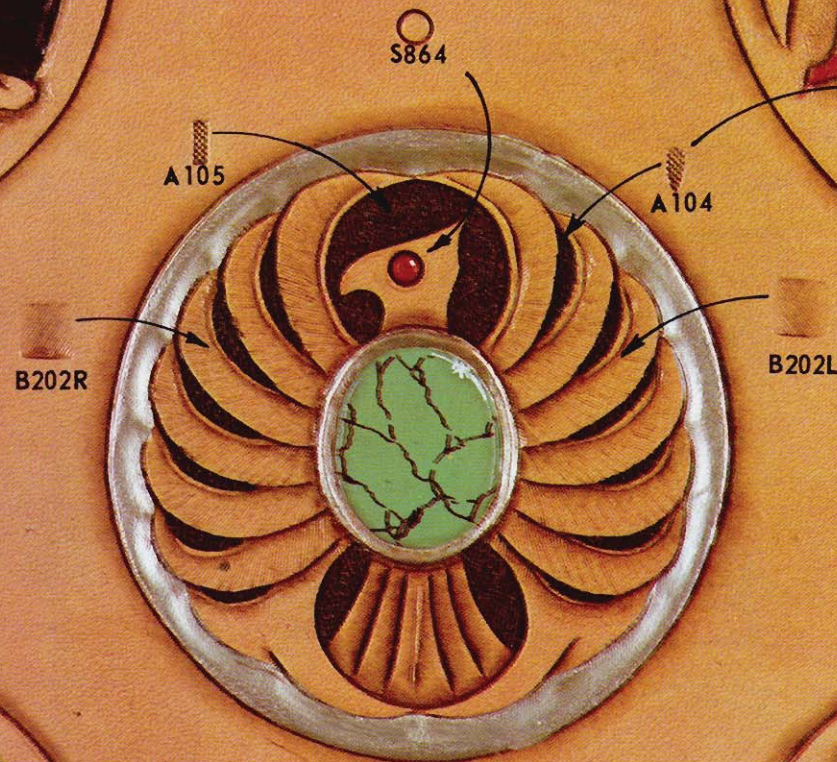
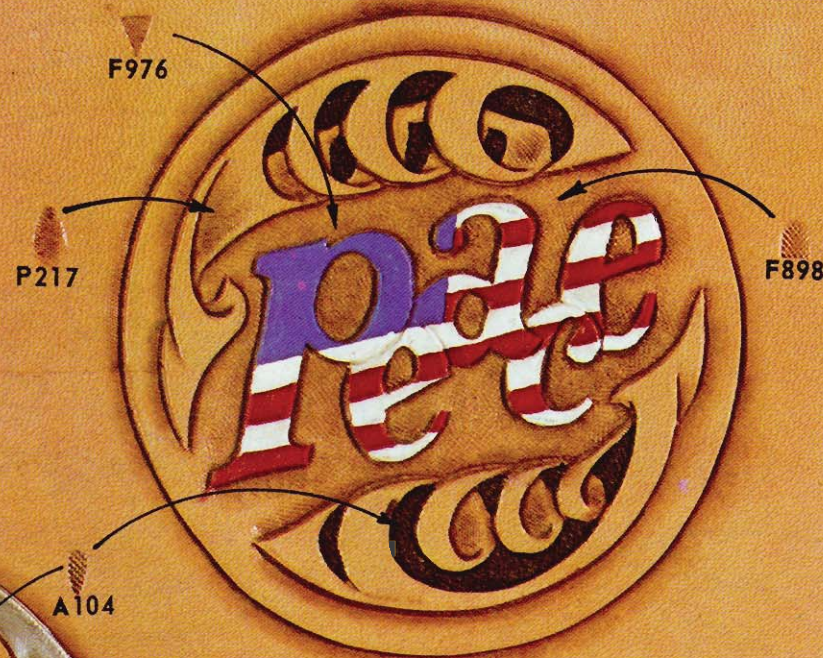
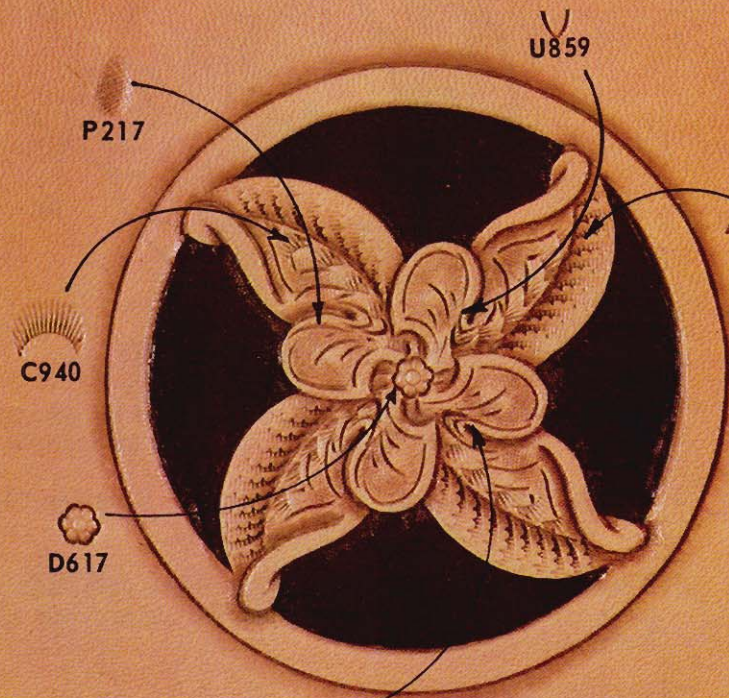

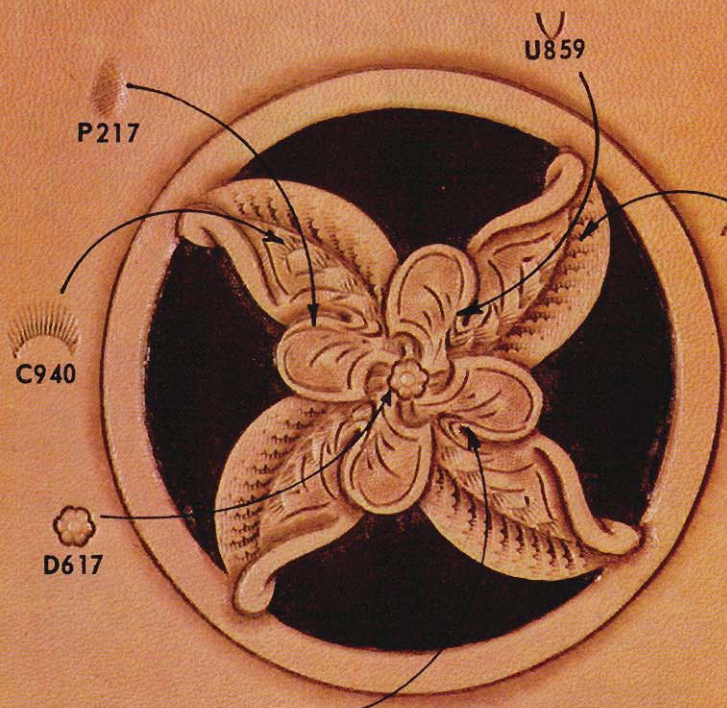

P217

U859

V708

C940

D617

H359



F976

P217

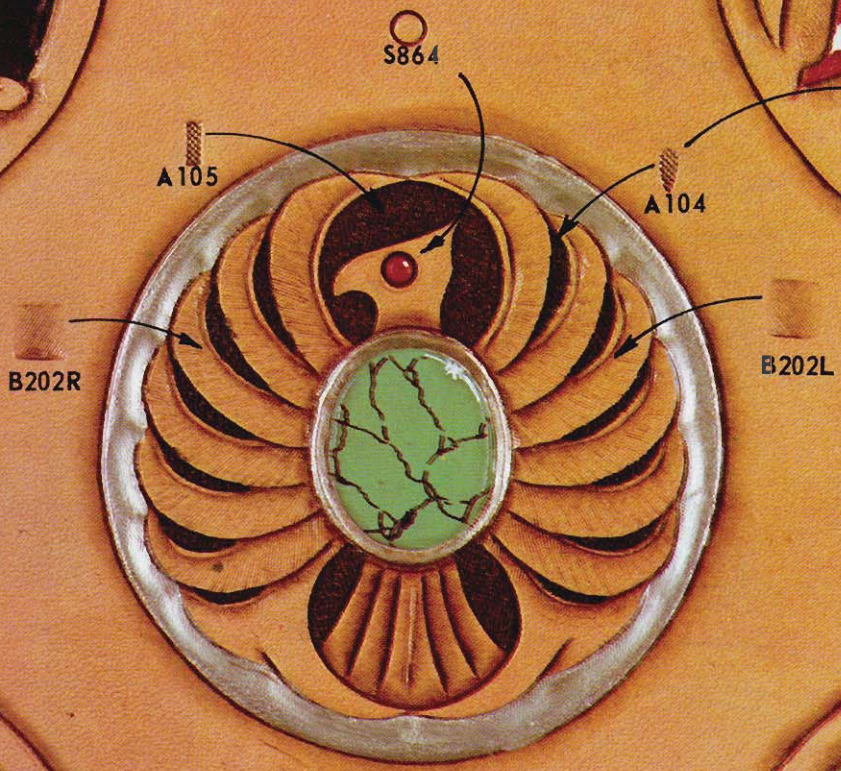

S864

A105

A104

B202R

B202L



F976



F976

S631

S932

S631

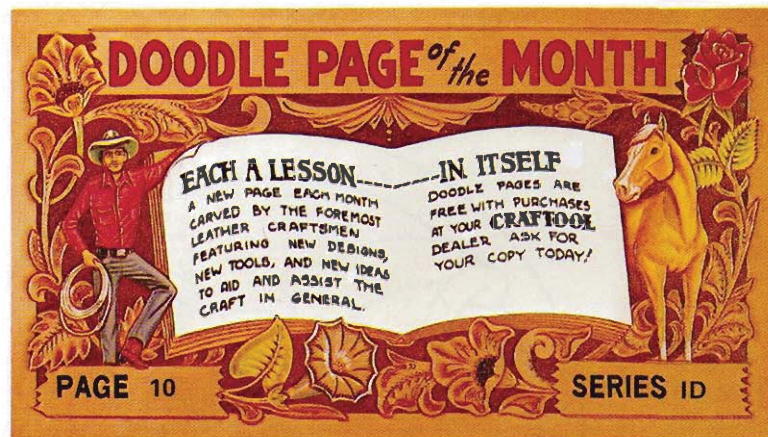
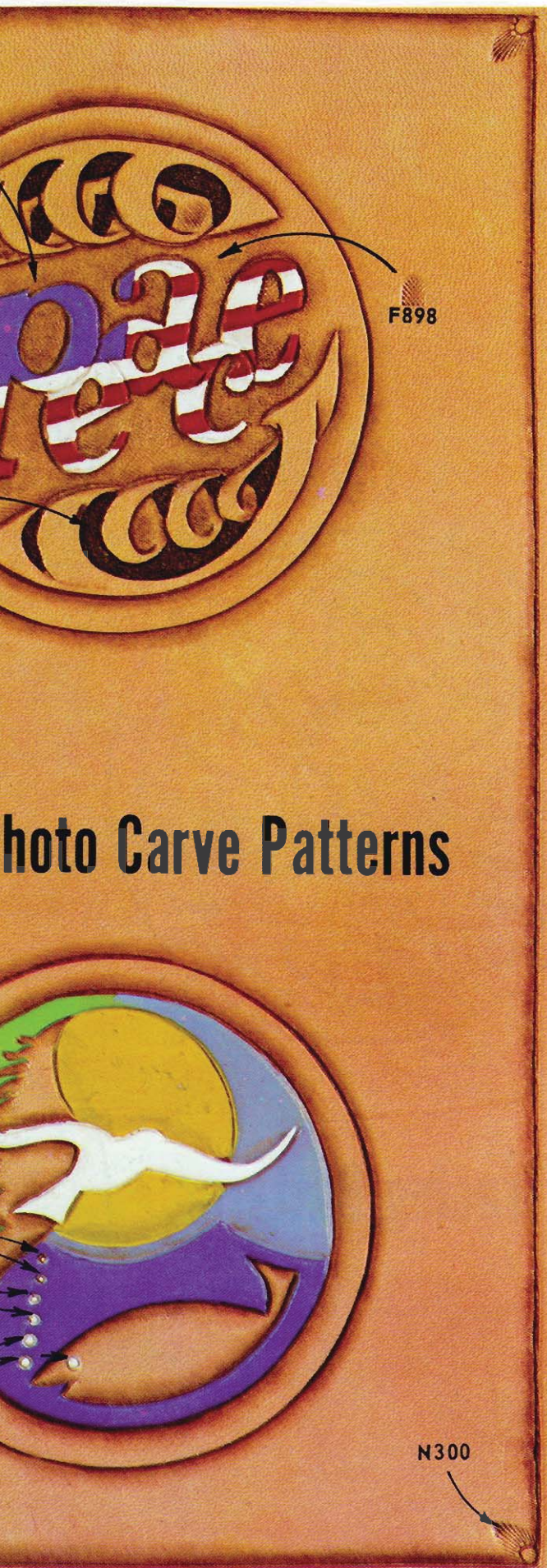

"ROUNDER BUCKLES"

by DAN NOLAND

These Rounder Buckle designs were designed in a modernistic and ecologicistic way. I have made other belt buckle designs, and I've seen Dad make some, but I was tooling some Rounders for coasters and thought these would make good buckles. You just carve one (#3) and put a buckle back ring and hook (#1) and the other (#2) and then glue them together with Craftsman cement. You can even lace them together if you want to.

Dad helped me a little on the layout of these designs and I am sure you can think of other designs for your own Rounders. I just hope these will give you the idea on how to make them.

After I did all the carving I colored them with Cova Dye. You may wish to use different colors than what I did or just make natural ones without color.

I am studying Drafting and Design at our Vo-Tech school and hope it will help me do other designs in the future.

I hope you like these designs that I've done and Good Luck in your Leather Carving.

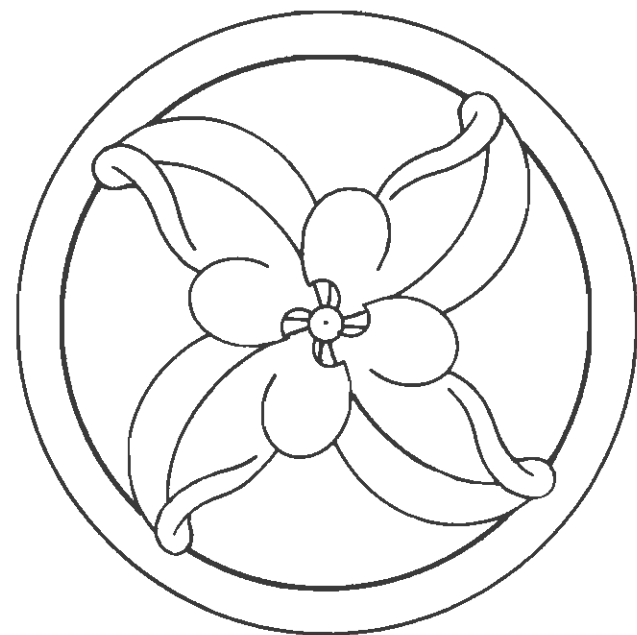

1



4

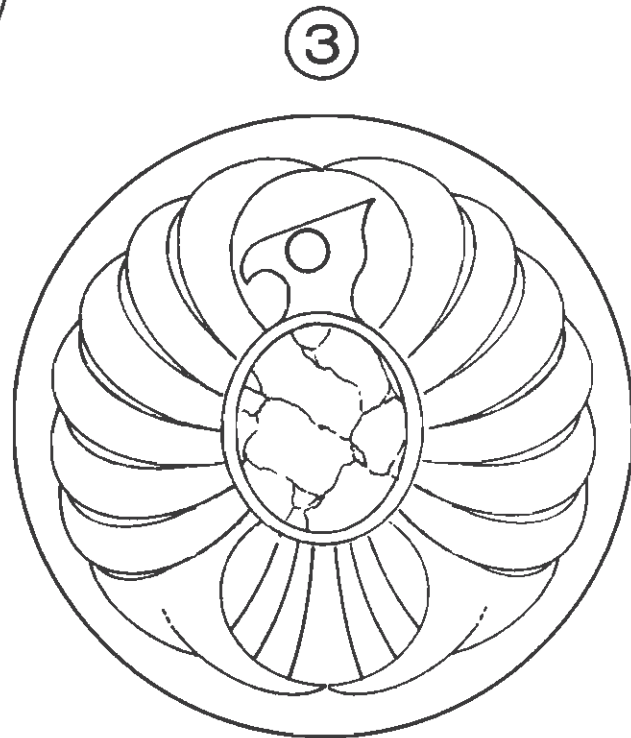

3

5

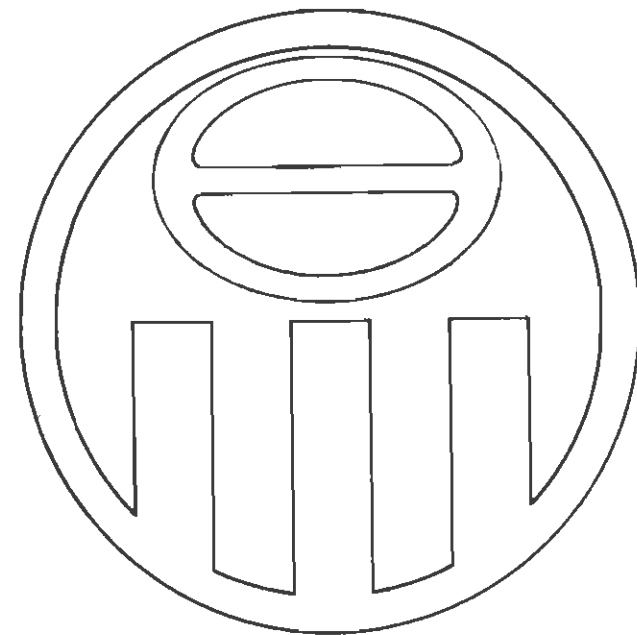

2



Tracing Patterns

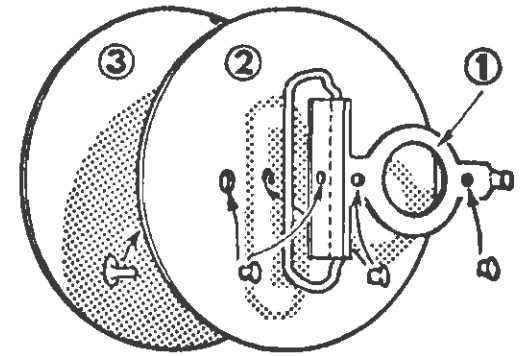

ASSEMBLY INSTRUCTIONS

1. Attach buckle back ring and hook (1) to the grain side of the Rounder (2) to be used for the back using rapid rivets.
2. Attach this assembly to the finished Rounder (3) with craftsman cement.
3. Round the edges with a large bevel-eze and slick with a piece of canvas or punch and lace using your favorite lacing technique.

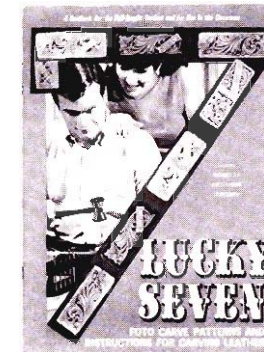

LUCKY 7 TEXT BOOK

Written for the home craftsman. Also for classroom. Fully illustrated. Wallet designs by 7 professional western craftsmen. . . . \$2.00

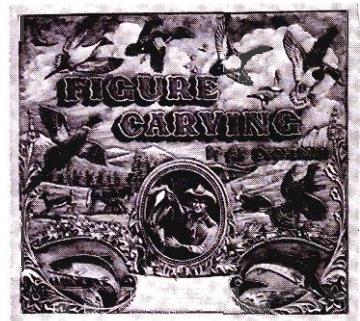
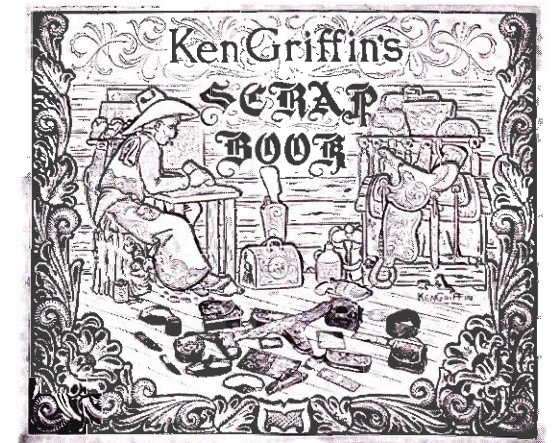

FIGURE CARVING

Featuring a NEW METHOD of instruction. Dozens of Figures and Dye-Charts. Covers are printed in full color. . . . \$2.00



Ken Griffin's SCRAP BOOK

A jumbo size book of designs and patterns. Pages 18" x 15" with full size tracings and Photocarve Patterns. Leather carving made easy. . . . \$5.00

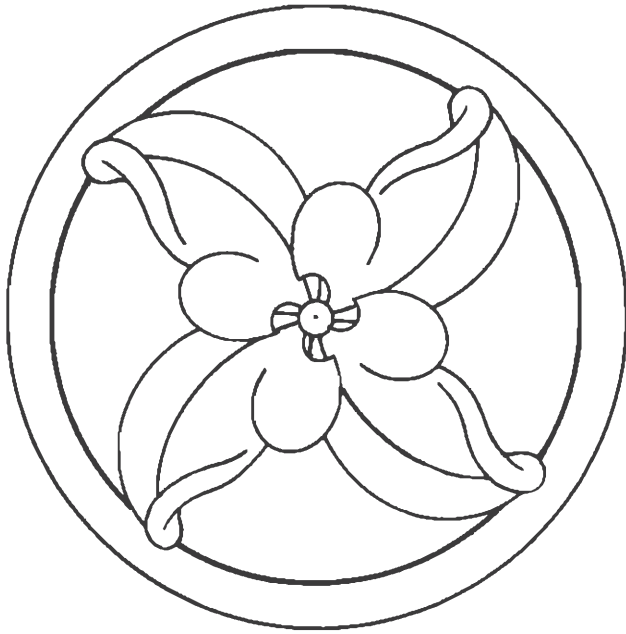

①

②

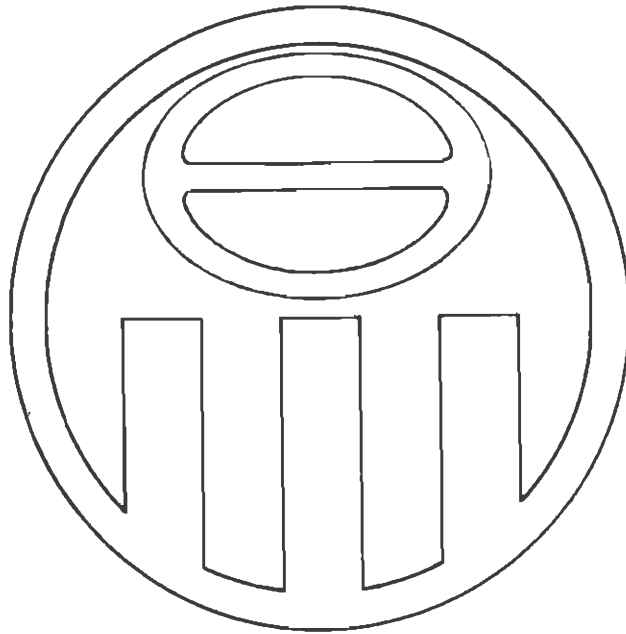

③



Tracing Patterns

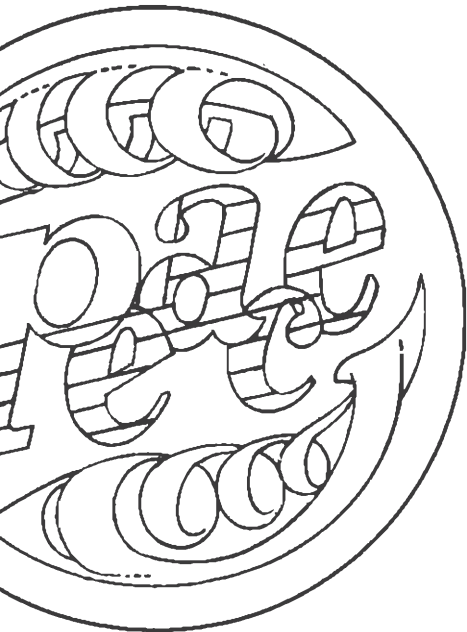

4

5

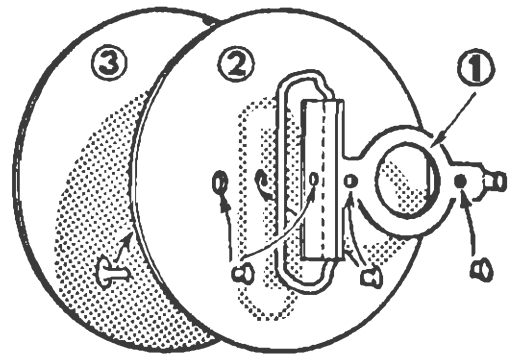

ASSEMBLY INSTRUCTIONS

1. Attach buckle back ring and hook (1) to the grain side of the Rounder (2) to be used for the back using rapid rivets.
2. Attach this assembly to the finished Rounder (3) with craftsman cement.
3. Round the edges with a large bevel-eze and slick with a piece of canvas or punch and lace using your favorite lacing technique.

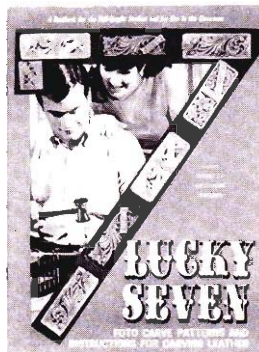

LUCKY 7 TEXT BOOK

Written for the home craftsman. Also for classroom. Fully illustrated. Wallet designs by 7 professional western craftsmen. . . . \$2.00



FIGURE CARVING

Featuring a NEW METHOD of instruction. Dozens of Figures and Dye-Charts. Covers are printed in full color. \$2.00

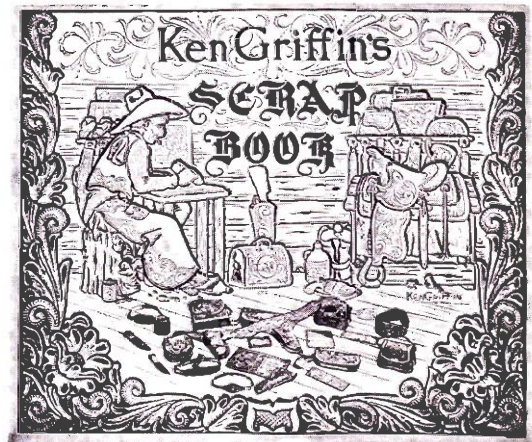

Ken Griffin's SCRAP BOOK

A jumbo size book of designs and patterns. Pages 18" x 15" with full size tracings and Photocarve Patterns. Leather carving made easy. \$5.00