

0-2700-04

HANDBAG KIT

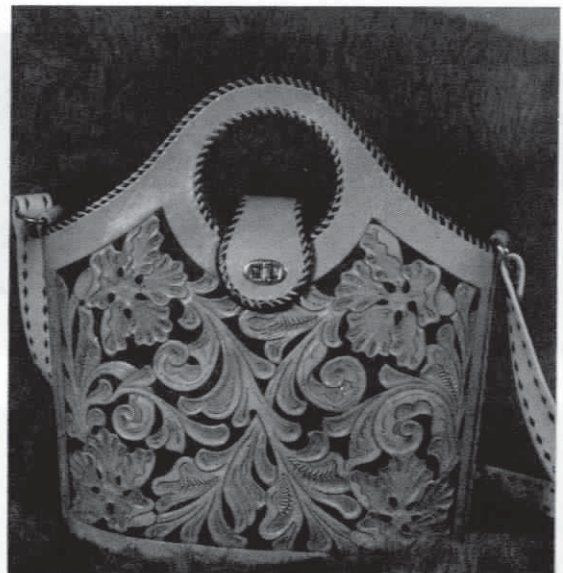

KIT CONTAINS:
Pre-Cut Leather Parts
Hardware
Patterns
Instructions

YOU WILL NEED:
Pliers
Wing Dividers
Knife
Cement
25 yds. 1/8" Lace
Lacing Needle
1/8" Multi-Prong Chisel
1/8" Single-Prong Chisel
Rivet Setter
No. 2 Round Drive Punch
No. 3 Round Drive Punch
Poundo Board
No. 8103 Snap Setter
Bone Folder

Lacing Nippers
Lining (Optional)
For Decorative Buckstitch:
4 yds. 3/16" or 5/32" Lace
5/32" Multi-Prong Chisel
5/32" Single-Prong Chisel

tandy Est. 1919
LEATHER COMPANY

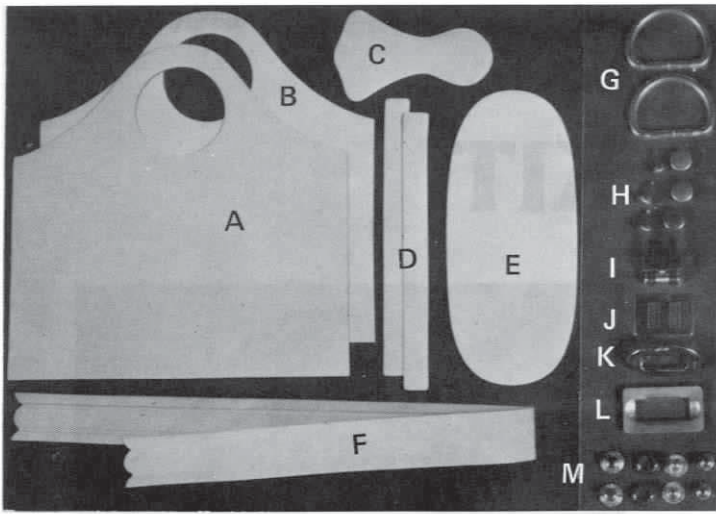

KIT PARTS:

- A— Bag Front
- B— Bag Back
- C— Closure Tab
- D— Side Strips
- E— Bottom Gusset
- F— Handle Strap
- G— Dees
- H— Rivets
- I— Bag Clasp
- J— Bag Clasp Back Plate
- K— Bag Clasp Eyelet
- L— Eyelet Back Plate
- M— Snaps

READ ALL INSTRUCTIONS CAREFULLY BEFORE BEGINNING

If you have chosen a pattern with decorative Buckstitching, follow Steps 1-3. If not, tool, dye and finish bag and begin at Step 4.

STEP 1. Before you transfer your tracing pattern to the leather, very, very lightly trace the Buckstitch line onto the DRY leather following line provided on tracing pattern.

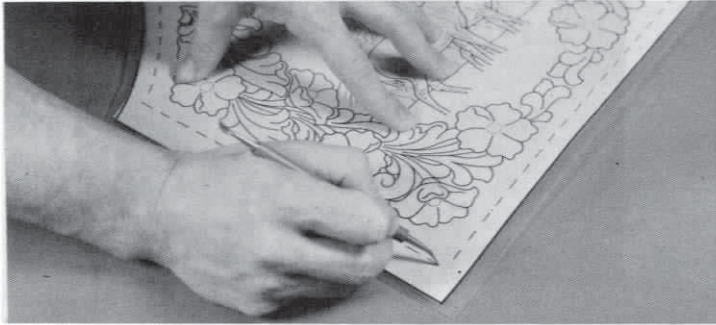

STEP 2. Place leather on rubber poundo board and punch Buckstitch holes using a 5/32" angled multi-prong chisel on the straight lines and a 5/32" single-prong chisel on the curved lines. A single-prong chisel is also used to even out the spacing as you reach a corner or the end holes. REMEMBER: You must have an even number of holes for Buckstitching. Place prongs on the inside of the guide line all the way around the bag.

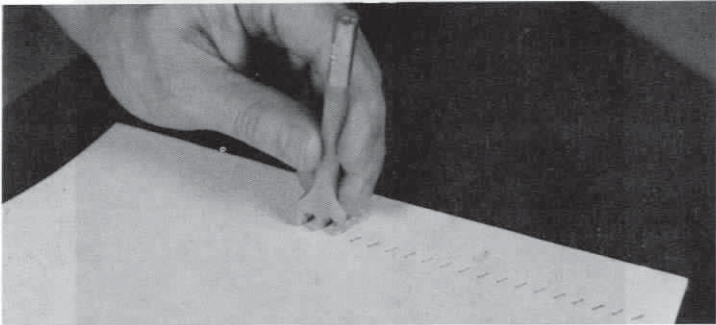

DO ALL TOOLING, DYEING AND FINISHING BEFORE CONTINUING

STEP 3. Using 2 yds. of 3/16" Florentine lace or 5/32" Buckstitch lace on each piece of the bag, do all decorative Buckstitching following instructions below.

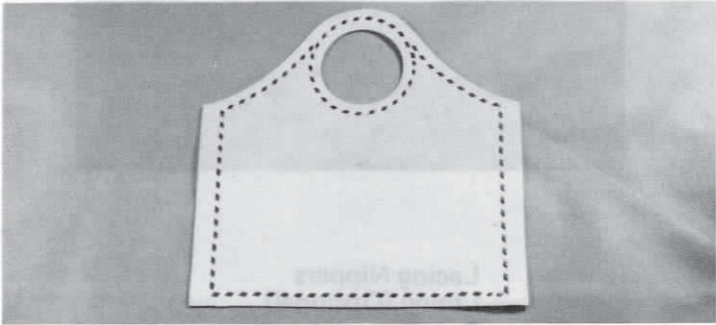

DECORATIVE BUCKSTITCHING INSTRUCTIONS

<p>A—Begin with 2 yds. of lace and cut a slit in one end as shown; place a two-prong lacing needle on other end.</p>	<p>B—From flesh (rough) side, push needle through first hole, leaving slit end on flesh side of leather.</p>	<p>C—Push needle through next hole, keeping lace straight, and through slit in end of lace. Pull stitch tight.</p>
--	--	--

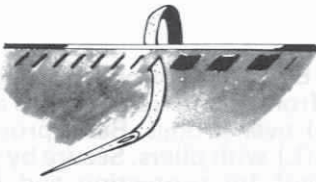

D—Lace up through next hole, being sure lace is not twisted. Grain (smooth) side of lace should be on grain side of bag. Continue stitching until you have about 4" of lace in needle.

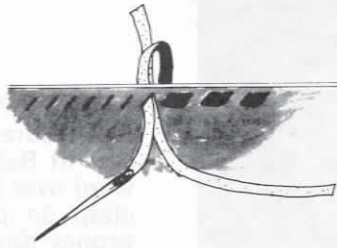

E—Leave a loose loop on back side of bag and remove needle from lace. Attach needle to new length of lace and pull needle through last hole stitched. (Flesh side of new lace rests on grain side of old lace.) Leave about 3/4" of new lace on flesh side of leather.

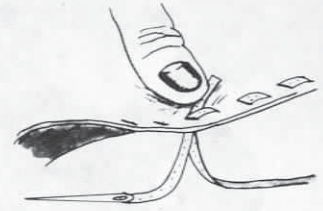

F—Hold end of new lace down with thumb. Pull old lace through until stitch is tight.

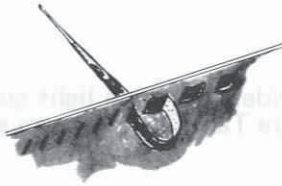

G—Trim off end of old lace just before next hole and run new lace through next hole, keeping end of old lace concealed under the stitch.

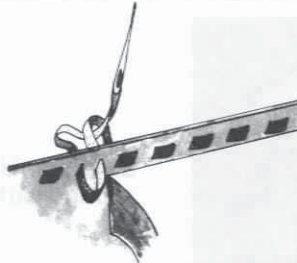

H—Continue lacing as before. Stitch up to the last two holes. To finish off, push lace through from back leaving a loose loop. Continue lacing, leaving a loose loop on front and run end of lace back through loop on back.



I—Pull all stitches tight and trim off end. Tap all stitches flat with a mallet.

STEP 4. Using a 1/8" single-prong chisel, punch holes for Bag Clasp (I) in Bag Front (A). (See tracing pattern for position of holes.) Insert prongs of Bag Clasp (I) through holes from grain side of Bag Front (A). Turn Bag Front (A) over and fit Clasp Back Plate (J) over prongs. Using pliers, bend prongs over Back Plate (J). Rest Clasp (I) on the edge of a poundo board and use a mallet to tap prongs flat against the Back Plate (J).

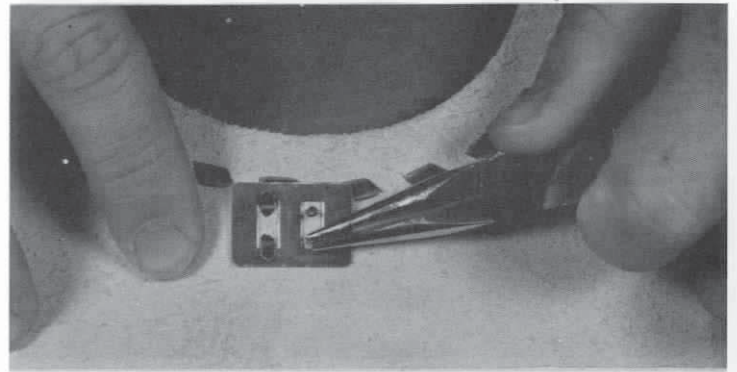

STEP 5. OPTIONAL. If you are lining your bag, cement closure tab lining to flesh side of Closure Tab (C) at this time. Trim lining if necessary.

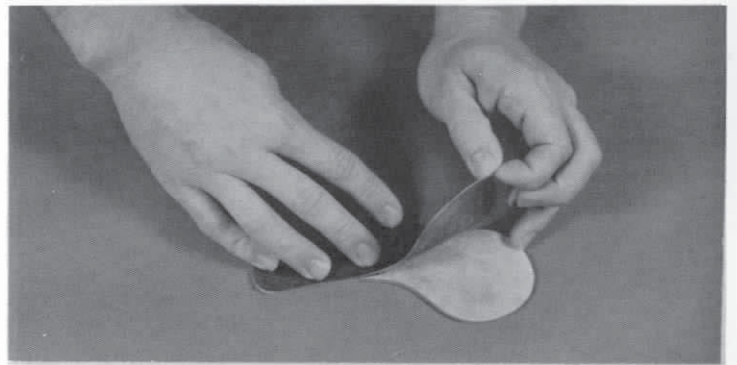

STEP 6. Using a sharp knife, cut out hole in Closure Tab (C) and lining for Bag Clasp Eyelet (K). (See tracing pattern for position.)

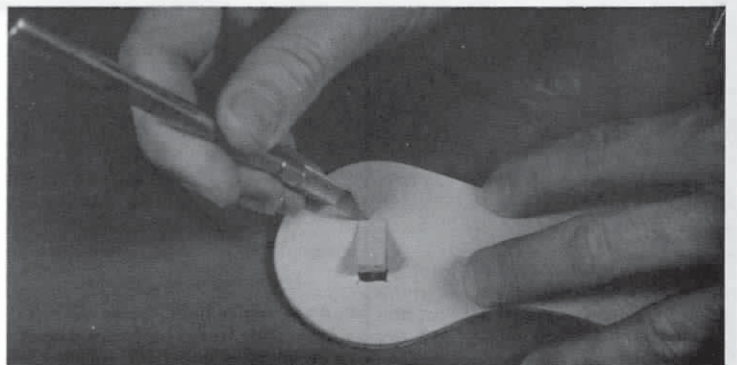

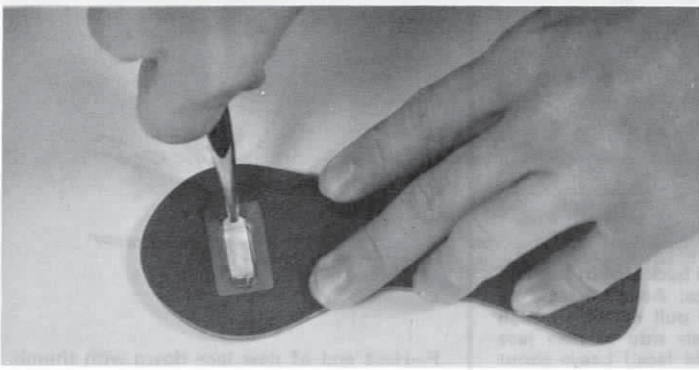

STEP 7. Push Clasp Eyelet (K) prongs through hole in Closure Tab (C) from grain side. Turn Tab over and fit Back Plate (L) over prongs. Bend prongs outward over Back Plate (L) with pliers. Secure by placing clasp on pounbo board for protection and tapping prongs down with a mallet into depressions in Back Plate (L).

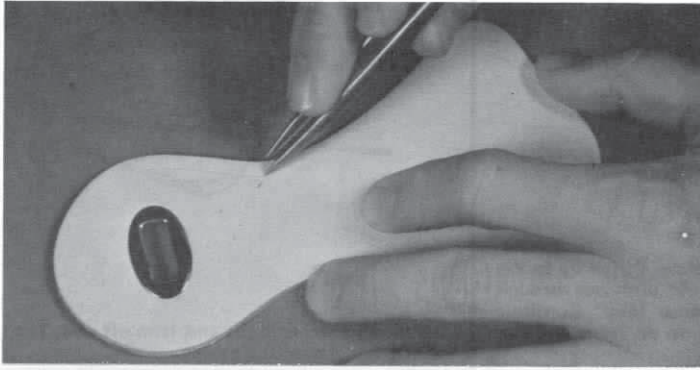

STEP 8. Using wing dividers, scribe a light guide line around outside of Closure Tab (C) 1/8" from edge.

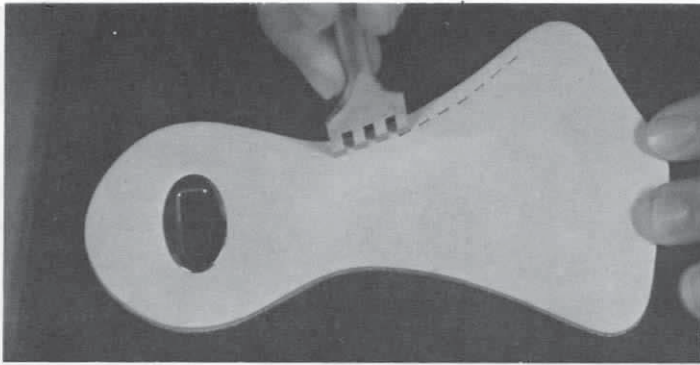

STEP 9. Using 1/8" multi-prong and single-prong chisels, punch lacing holes along scribed line 1/8" apart.

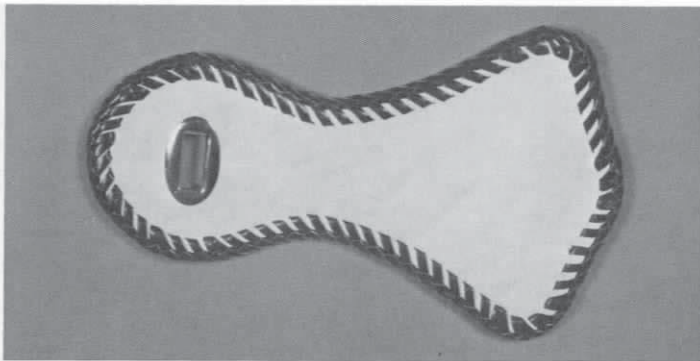

STEP 10. Using 1 1/2 yds. of lace at a time, (3 yds. in all) lace around Closure Tab (C) following Double Loop Lacing Instructions.

DOUBLE LOOP LACING INSTRUCTIONS

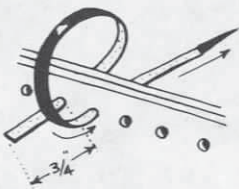

Beginning on front side of project, pull the needle and lace through the 1st hole. leave about 3/4" of the lacing end and go on to lace the next hole.

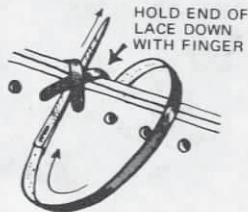

Pull the stitch tight, lacing over the end you left free. This forms a cross or "bight".

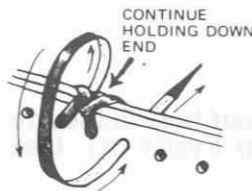

Pull the stitch under the bight snug but not tight. Lace through the next hole.

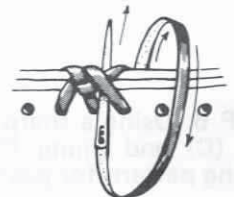

Follow the same procedure as in Steps 1 and 2 making a cross or bight. Once again go under the bight and pull the stitch snug.

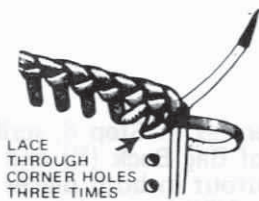

When lacing a corner, stitch it three times. Be sure to go through bight on corner stitches.

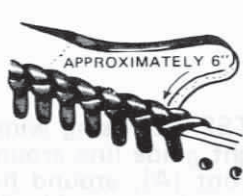

Lace until only 5" or 6" of lacing remain. You will now have to splice with a new length of lace.

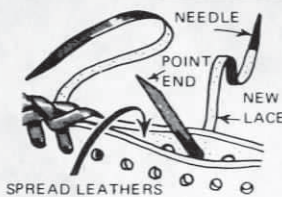

Insert new lacing down between leathers, 4 holes from lacing; pull out back side. Leave 3/4" of lacing with the old lace.

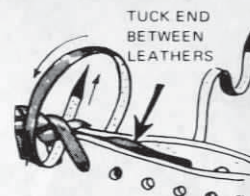

Tuck end of lace between leathers and continue lacing your project with the old lace.



Pull the old lace up tight, cut off the end at an angle, allowing about 3/4" to remain. Attach needle to new lacing.

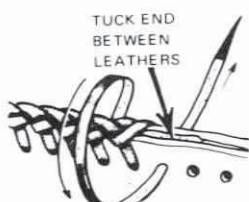

Tuck the end of the old lacing between the leathers and lace over it with the new lace so that it is caught and won't show.

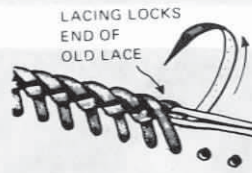

Continue lacing to starting point.

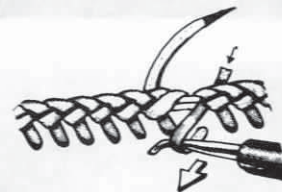

To tie off lacing, pull end of beginning lace free of stitches.



From back side pull the end of lace out of the hole.

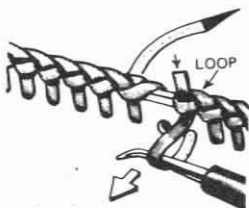

From front side, pull end of lace out of the loop.

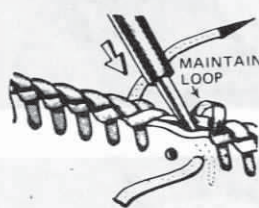

Push tool or needle down between leathers and hook it over the lace.



Pull end of lace out of hole and up between leathers. Two empty holes should appear on the front side; one on the back.

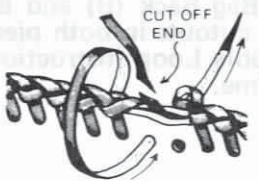

Cut off the end of the lace you have pulled out and tuck the end of the lace between the leathers. Lace through the next hole.

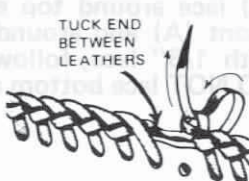

Pull stitch tight and lace up through loop from the back side. All holes on the back should be filled.



Lace under the bight. . . do not pull this stitch tight.

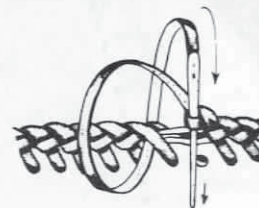

Carefully cross over as shown. . . and push needle down through the loop.

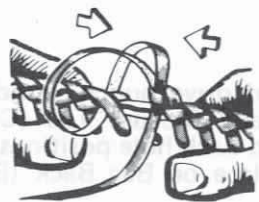

Pull needle through. Push laced edges together to adjust starting loops for easier completion.

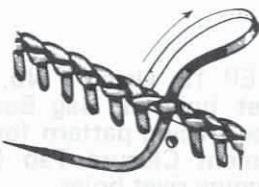

Pull any slack out of the first loop and adjust lacing with fingers to make all your stitches appear equal.



Pull the end of the lacing down tight. Make sure all stitches appear even and equally spaced.

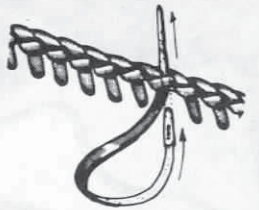

Push needle through the last hole as shown. Bring it up between the leathers and out between the lacing. Cut off the excess lace.

STEP 11. OPTIONAL: If you are lining your bag, cement Bag Front (A) and Bag Back (B) linings in place at this time. Trim linings if necessary.

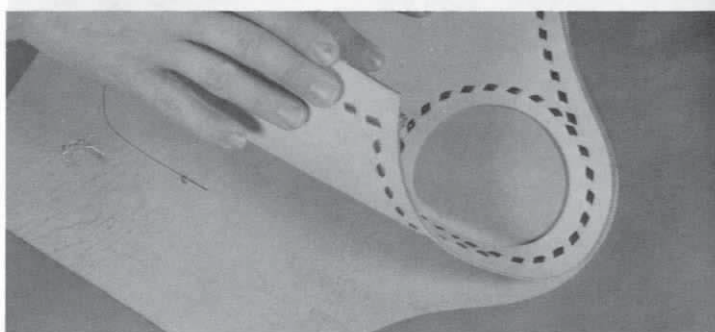

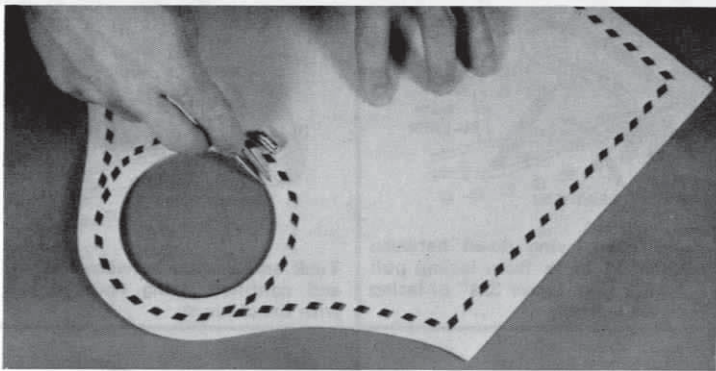

STEP 12. Using wing dividers as in Step 8, scribe a light guide line around top of Bag Back (B) and Bag Front (A), around handle cutout in both pieces and across bottom of both pieces, 1/8" from edges.

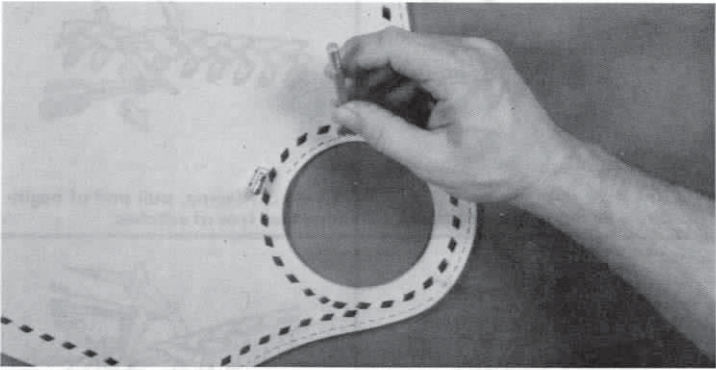

STEP 13. Using 1/8" multi-prong and single-prong chisels, punch lacing holes along scribed lines of handle cutouts and bottom of Bag Front (A) and Bag Back (B).

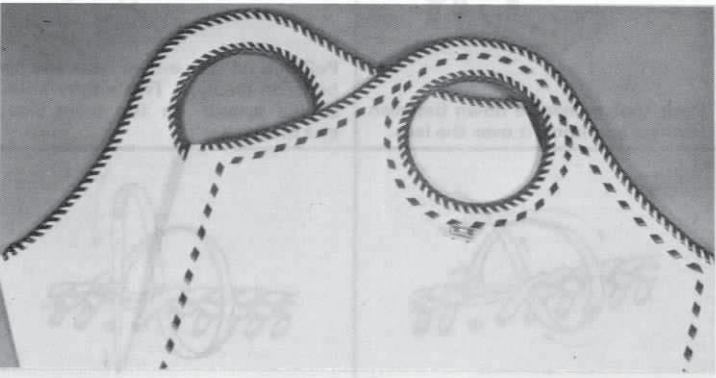

STEP 14. Using 1 1/2 yds. of lace at a time (10 yds. in all) lace around top edge of Bag Back (B) and Bag Front (A) and around handle cutouts in both pieces with 1/8" lace, following Double Loop Instructions. DO NOT lace bottom at this time.

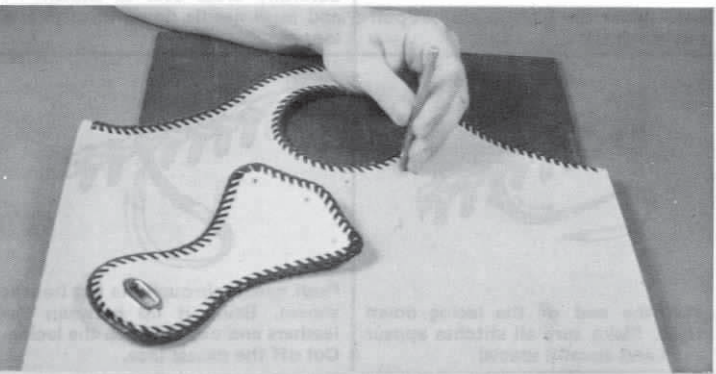

STEP 15. Using a No. 2 round drive punch, punch rivet holes in Bag Back (B) and Closure Tab (C). (See tracing pattern for tab and back hole positions.) Cement Closure Tab (C) in place on Bag Back (B) aligning rivet holes.

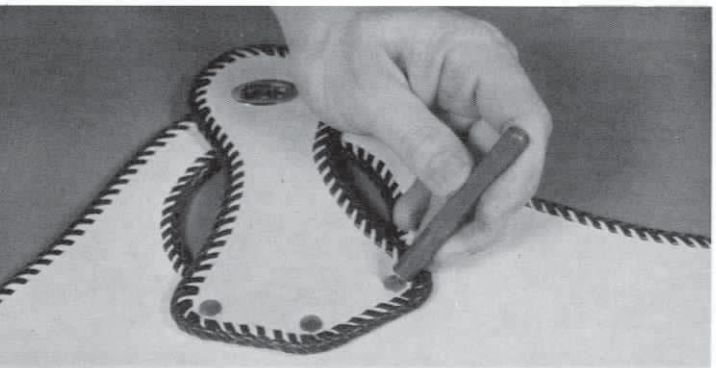

STEP 16. Insert rivet base through hole from flesh (lining) side of Bag Back (B) and place base of rivet on anvil or hard riveting surface. Place rivet cap on top of rivet base on grain side of Closure Tab (C) and place concave end of rivet setter on rivet cap. Strike setter sharply with a mallet until cap and base lock together. Set other two rivets.

STEP 17. Butt sides of Bag Front (A) and Bag Back (B) against each other. Center flesh side of Side Strip (D) over grain side of seam and using rubber cement, cement in place with bottom of Side Strip (D) even with bottom of Bag Front (A) and Bag Back (B).

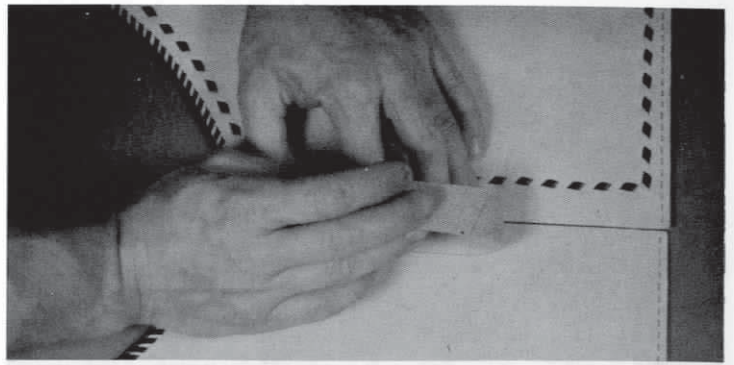

STEP 18. Fold top of Side Strip (D) over dee ring and top of bag, pulling it down snug against top of bag. Cement in place on flesh (lining) side of bag.

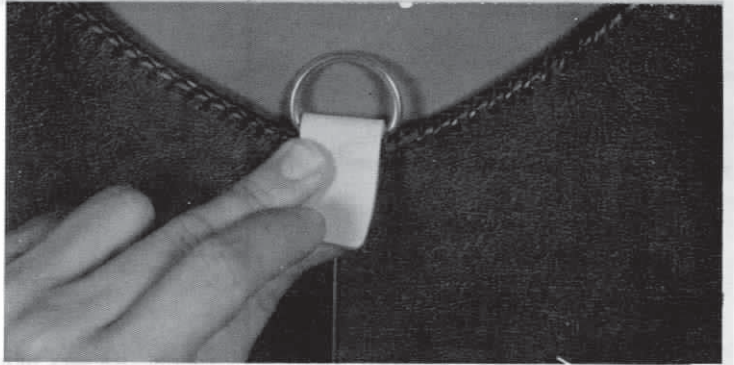

STEP 19. Lightly scribe a line down each side of the Side Strip (D) 1/8" from edge.

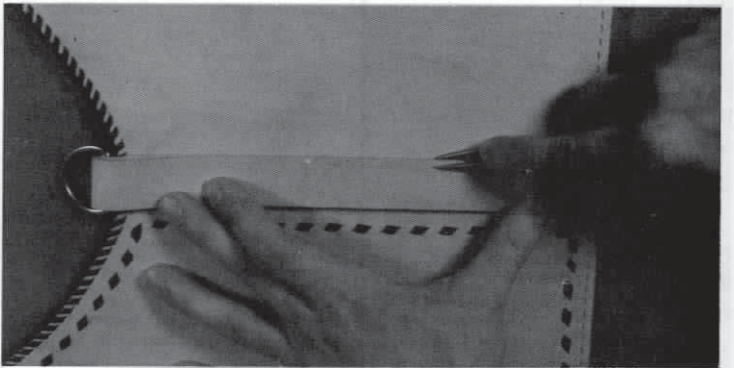

STEP 20. Using 1/8" straight multi-prong chisel, punch holes through Side Strip (D) and bag bodies. Holes should start 3/8" from bottom of strip, and stop 5/8" from fold at top of strip. Be sure to punch an even number of holes in each side of Side Strip (D). Adjust spacing with 1/8" single-prong chisel as necessary.

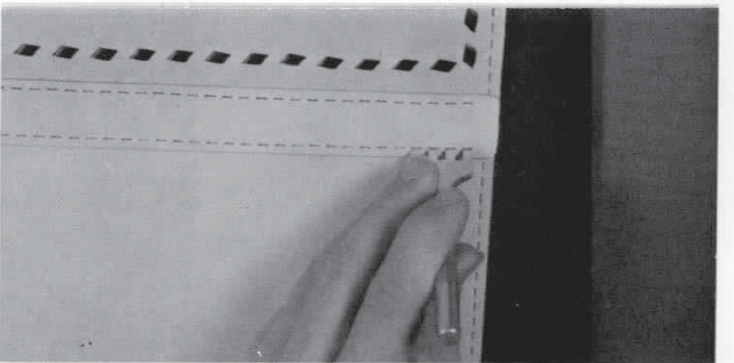

STEP 21. When you have punched all holes in Side Strip (D) and bag bodies, peel one side of Side Strip (D) off and repeat Steps 17-20 on other side of bag with other Side Strip (D).

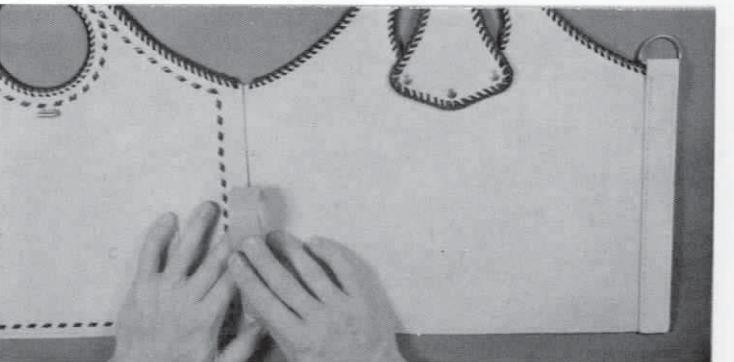

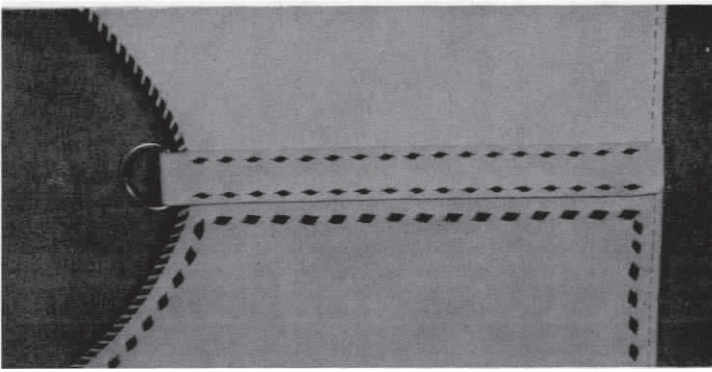

STEP 22. Using 1 yd. per side of bag, Buckstitch Side Strip (D) to sides of bag with 1/8" lace, following Functional Buckstitch Instructions below.

FUNCTIONAL BUCKSTITCH INSTRUCTIONS

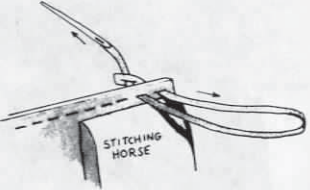
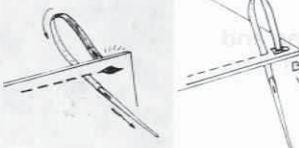
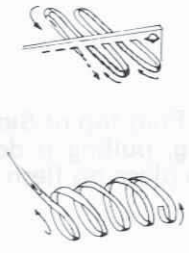
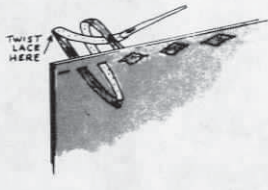
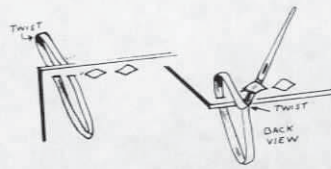
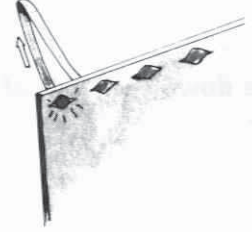
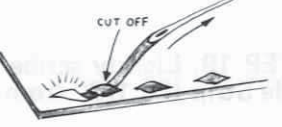
 <p>A—Prepare lace as in Step A of Decorative Buckstitch Instructions. Begin lacing in top hole in side being sure to catch folded part of strip on inside of bag. Pull lace through first slit, flesh side up. Go through next slit, with grain side of lace up and through slit in end of lace. Pull stitch tight.</p>	 <p>B—Bring lace back through 3rd slit, flesh side up.</p>	 <p>C—Continue lacing through slits as shown; grain side up, going to the back and flesh side up, coming to front. Pull each stitch tight as you go.</p>	
 <p>D—Continue lacing to bottom of bag and then lace back up to top of bag. Lace through last two slits as shown. Run end under back loop. Twist end so that flesh side of lace is against back of project.</p>	 <p>E—Pull back loop down tight. End should be flesh side against lining.</p>	 <p>F—Pull front loop down tight.</p>	 <p>G—Pull end through to tighten the twist in the end and tap all stitches down with a mallet.</p>

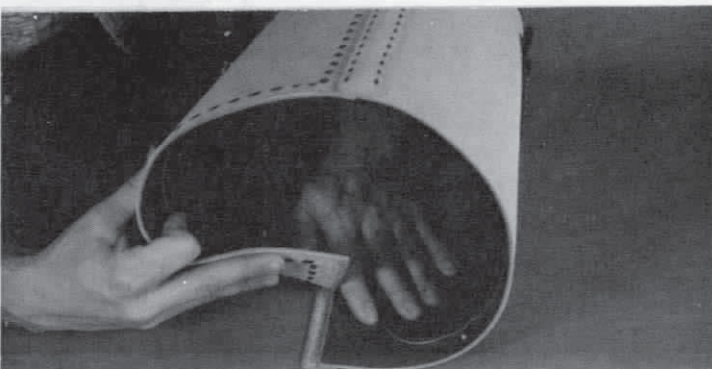

Step 23. Re-cement other Side Strip (D) to other edge of the bag and repeat Step 22 on this end of bag.

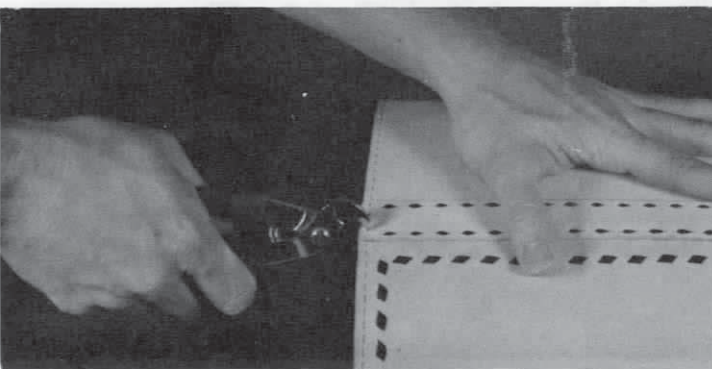

STEP 24. Using Lacing Nippers, punch lacing holes in bottom ends of side strips by aligning bottom prong of nippers in holes in bottom of bag body and punching through side strip.

STEP 25. With a sharp knife, cut 45 degree notches in Bottom Gusset (E) as shown on pattern sheet. Dampen the skived area on flesh side of Bottom Gusset (E). Lay gusset on table, grain side up and fold edges up approximately $5/16''$ all the way around. Form edges to stand at a 90 degree angle to the bottom. Using a bone folder, crease the inside edge at the fold. This will help the Bottom Gusset (E) hold its form. Allow to dry.

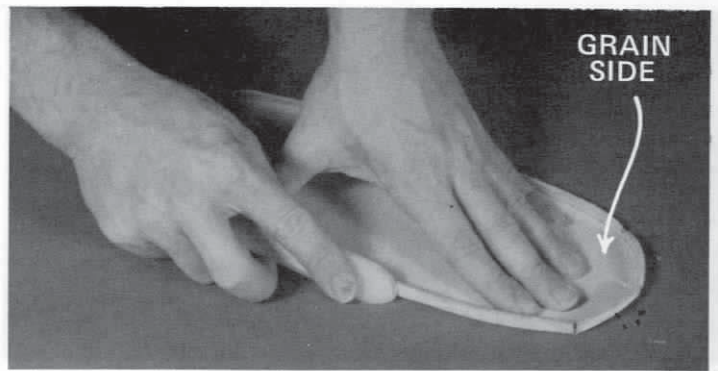

STEP 26. OPTIONAL: If you have lined your bag, cement the bottom gusset liner to the Bottom Gusset (E) at this time. It will be necessary to cut corresponding notches in the liner to make it adhere smoothly. Trim excess lining if necessary.



STEP 27. Apply cement to turned edges of Bottom Gusset (E) and corresponding edges inside Bag Front (A) and Bag Back (B). (If you have lined your bag you will need to scuff the turned edge of the bottom gusset liner to make the cement adhere better.) Cement Bottom Gusset (E) in bag aligning the two notches in the very ends of Bottom Gusset (E) with side seams. Adhere ends of bottom in first and carefully work around bottom adhering edges as you go.

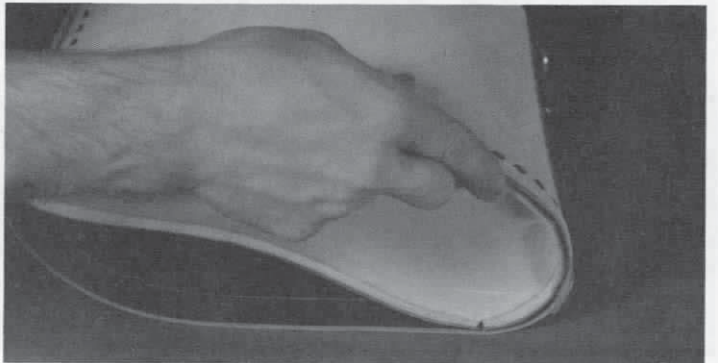

STEP 28. Using Lacing Nippers, punch lacing holes in Bottom Gusset (E) by aligning top prong of nippers in lacing holes in bottom of bag body and punching holes in bottom of gusset to correspond.

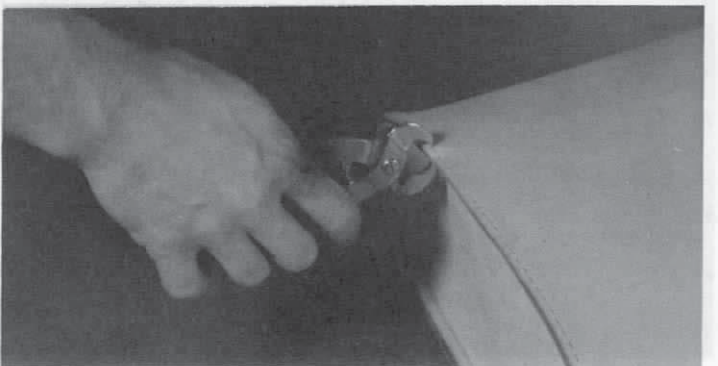

STEP 29. Using $1\frac{1}{2}$ yds. of $1/8''$ lace at a time, (6 yds. in all) lace around bottom of bag following Double Loop Instructions.

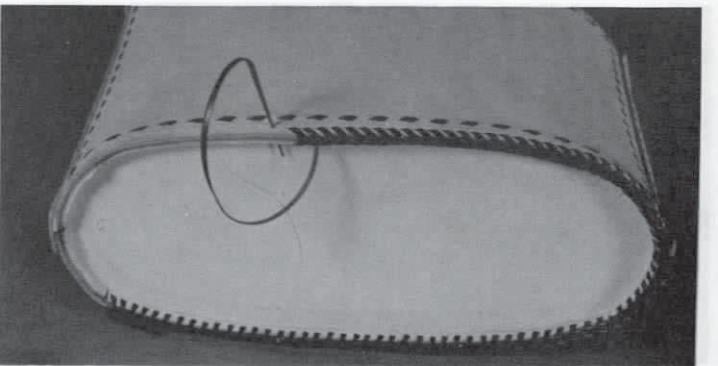



STEP 30. Fold edges of Handle Strap (F) over and cement in place as shown. Tap flat with a mallet.

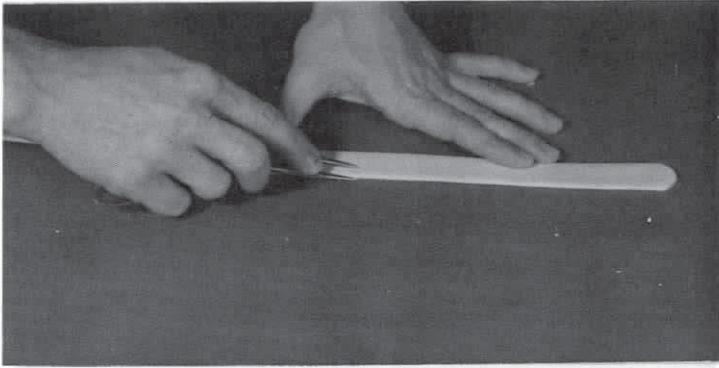

STEP 31. Scribe guide lines down each side of strap 1/4" from edges.

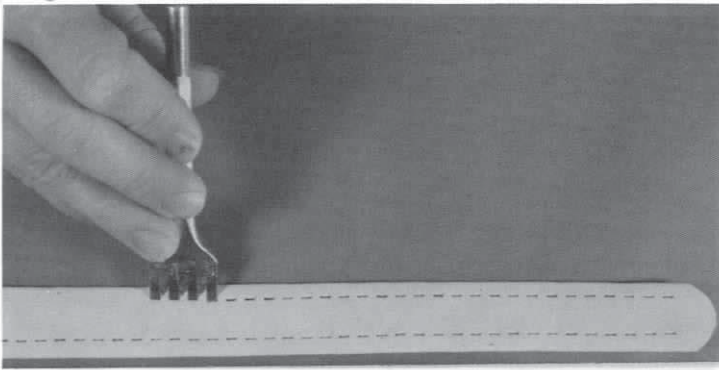

STEP 32. Punch Buckstitch holes with 1/8" straight multi-prong chisel; punch holes down both edges of entire length of Handle Strap (F). Adjust spacing as necessary to make number of holes come out to an even number.

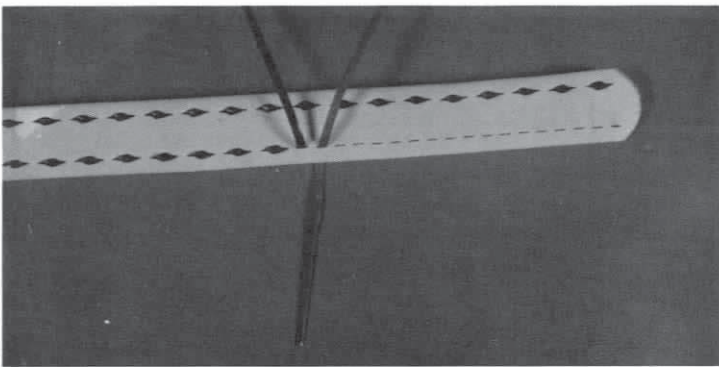

STEP 33. Using 1 1/2 yds. of 1/8" lace on each side, buckstitch Handle Strap (F) as you did in Functional Buckstitching, Step 22.

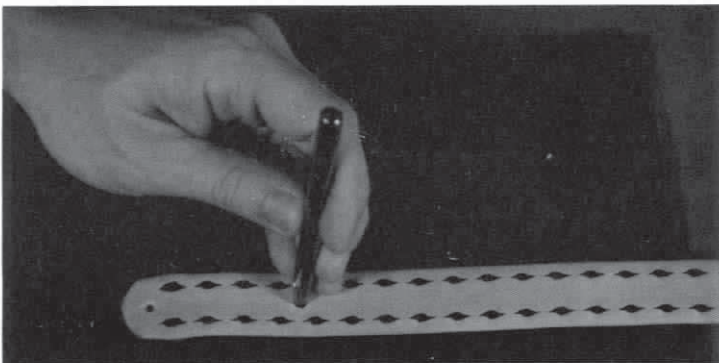

STEP 34. Using No. 2 round drive punch for eyelet holes, punch a hole in Handle Strap (F) about 3/4" from end of strap in each end of Handle Strap (F). Using No. 3 round drive punch for socket holes, punch a hole in each end of the strap about 3" up from eyelet holes.

STEP 35. Install snaps in ends of Handle Strap (F) following Snap Setting Instructions below.

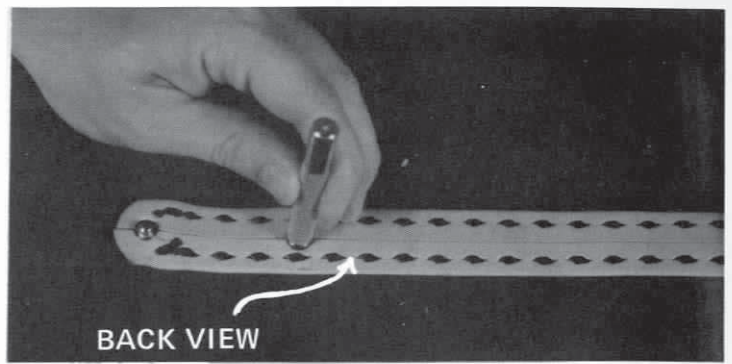

SNAP SETTING INSTRUCTIONS

HOW TO SET SEGMA SNAPS

SNAP PARTS

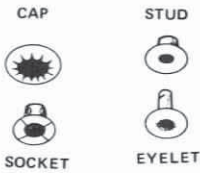

SETTING THE STUD AND EYELET

To set the stud and eyelet use large opening for line 16 belt snaps and small opening for line 16 glove snaps. Place stud in proper opening. Align hole in leather over stud and insert eyelet through hole in leather and into opening in stud. Place prong of proper setter into opening in base of eyelet. Strike setter sharply with mallet. NOTE: If you are using belt snaps with finished backs, do not use this setter. The procedure is the same except use your #8100 Rivet Setter or strike sharply with a metal hammer. If a metal hammer is used, be sure the eyelet is straight when using this procedure or the eyelet may bend and not set properly.

SETTING THE CAP AND SOCKET

Place anvil on a hard work surface with concave snap cap side up. Position cap in place. Center snap hole in leather over the cap and insert socket through hole in leather into opening in cap. Insert prong of proper setter (SB 16 for belt, SG 16 for glove) in opening of socket. Strike setter sharply with mallet, but don't overdo it.

1 SEGMA BELT SETTER FOR CAP AND SOCKET



1 STUD AND EYELET SETTER

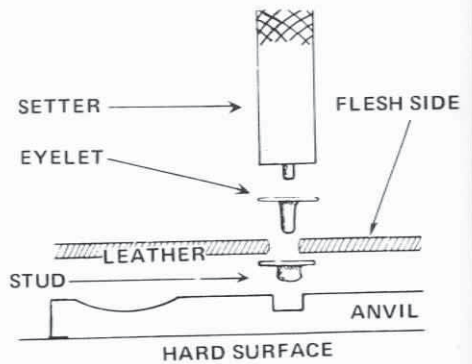
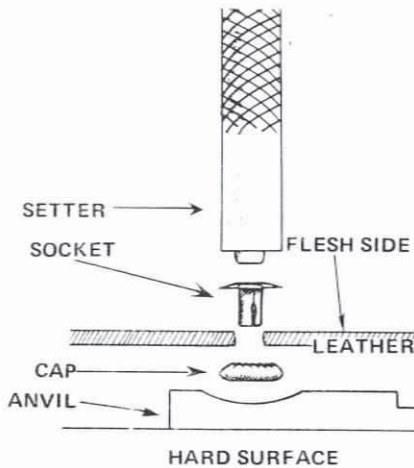

SETS: LINE 16 SEGMA GLOVE SNAPS (16SG)
LINE 16 SEGMA BELT SNAPS (16SB)

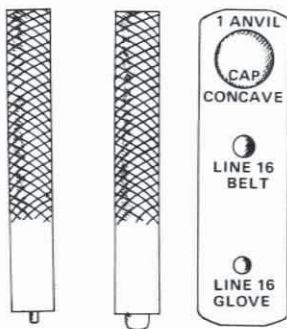

STEP 36. Snap Handle Strap (F) around dee rings on sides of bag. Congratulations! You've finished.



Pattern by Kathleen Bond

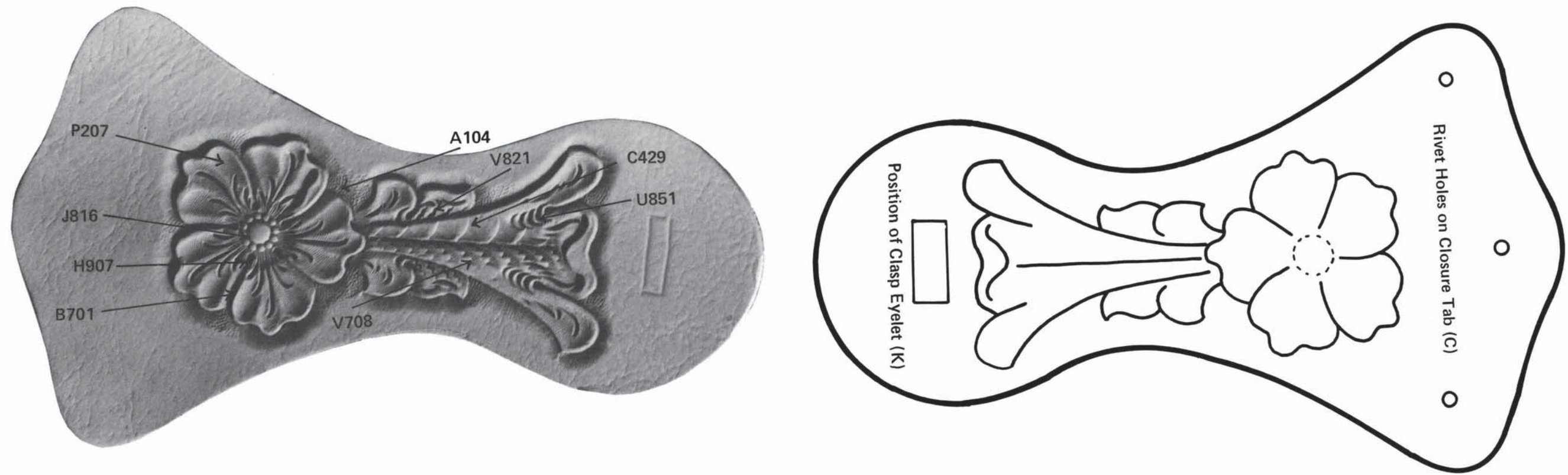
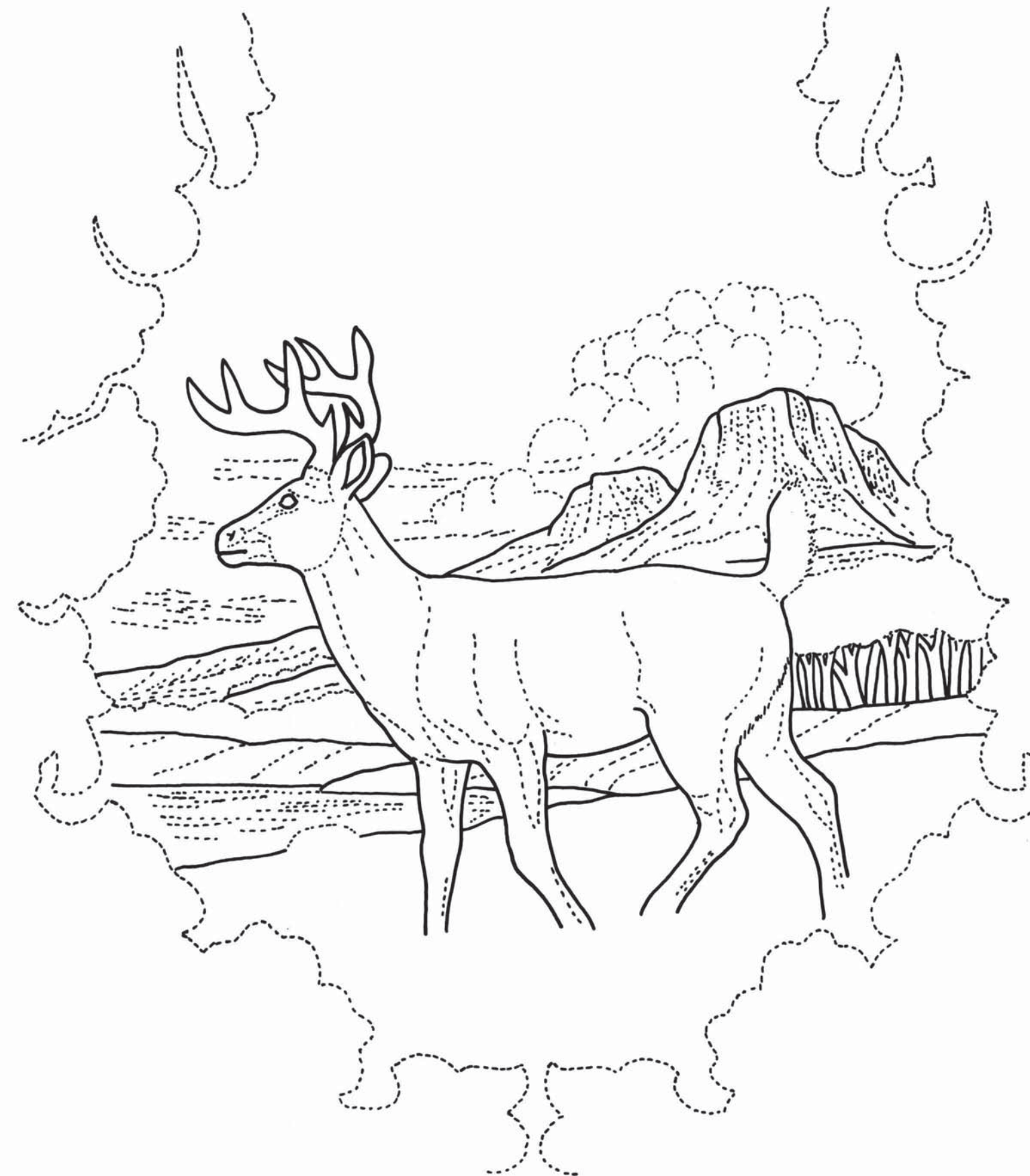
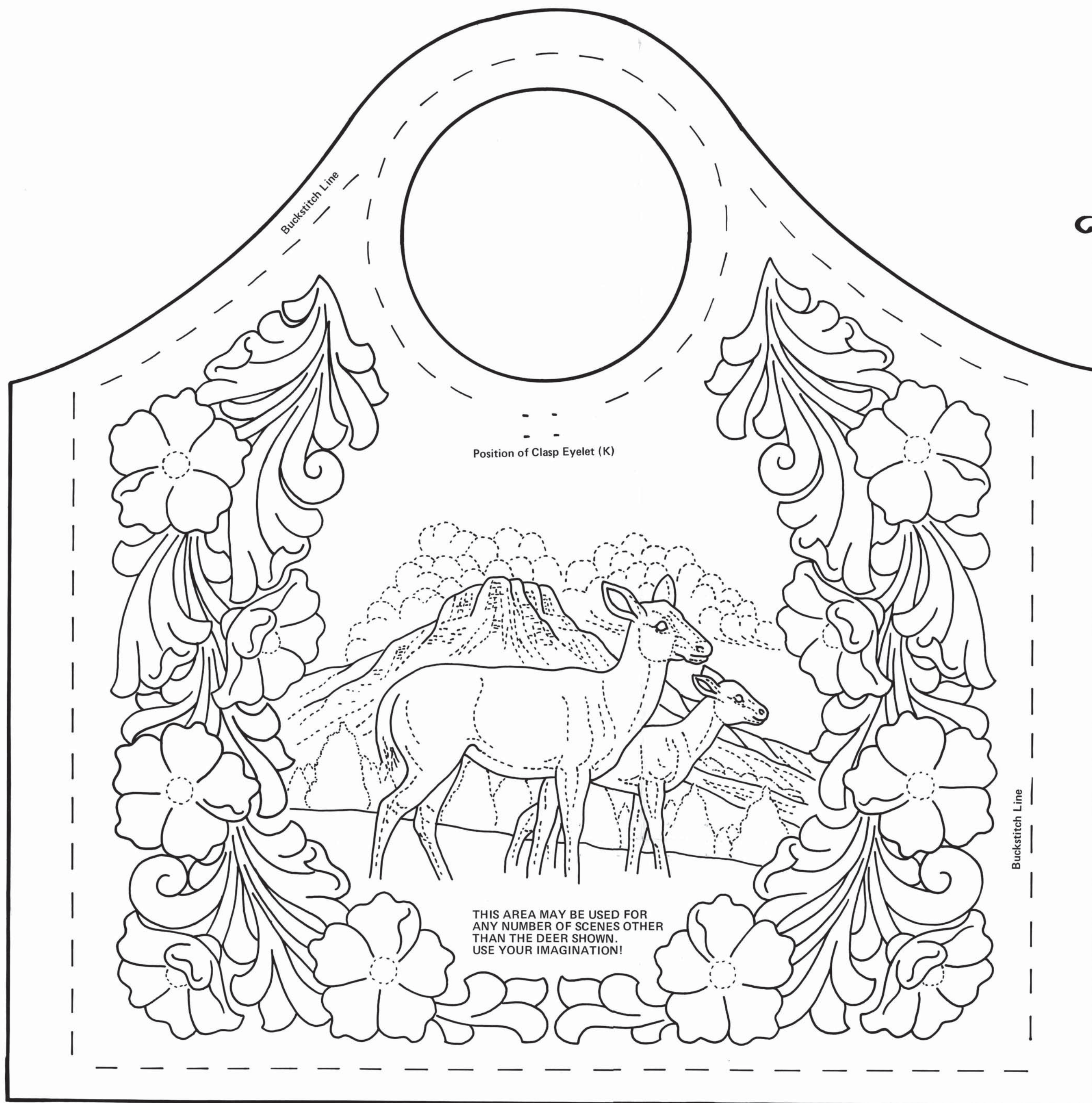

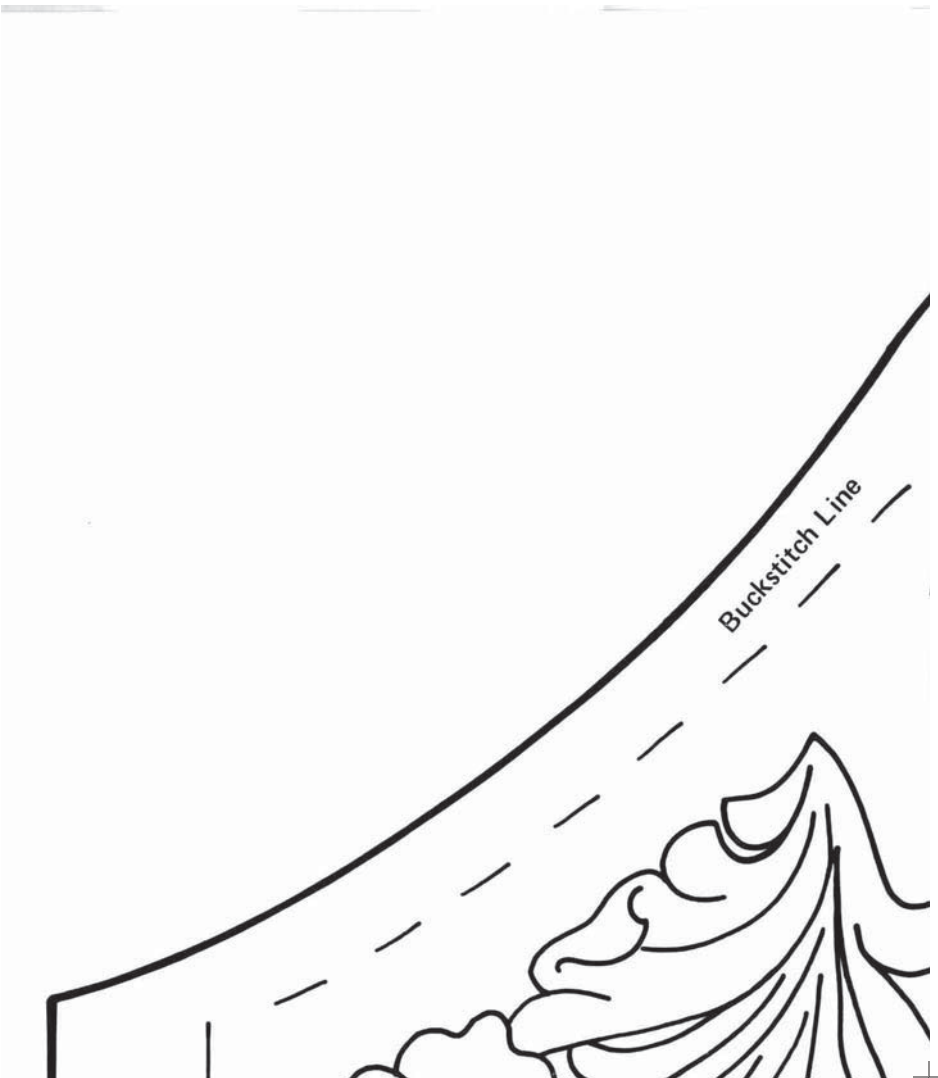

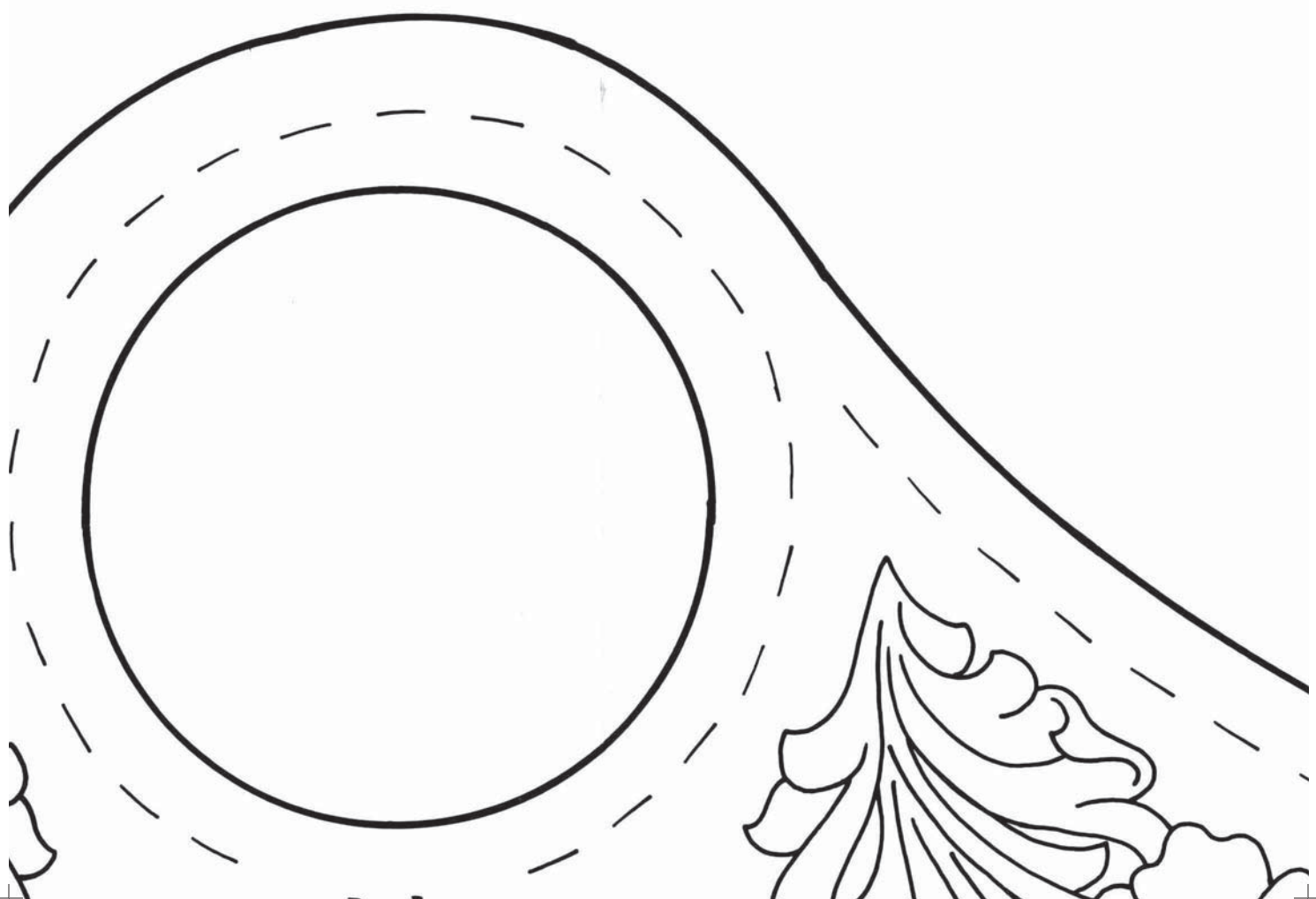

Pattern
by

Kathleen Bond







Position of Clasp Eyelet (K)

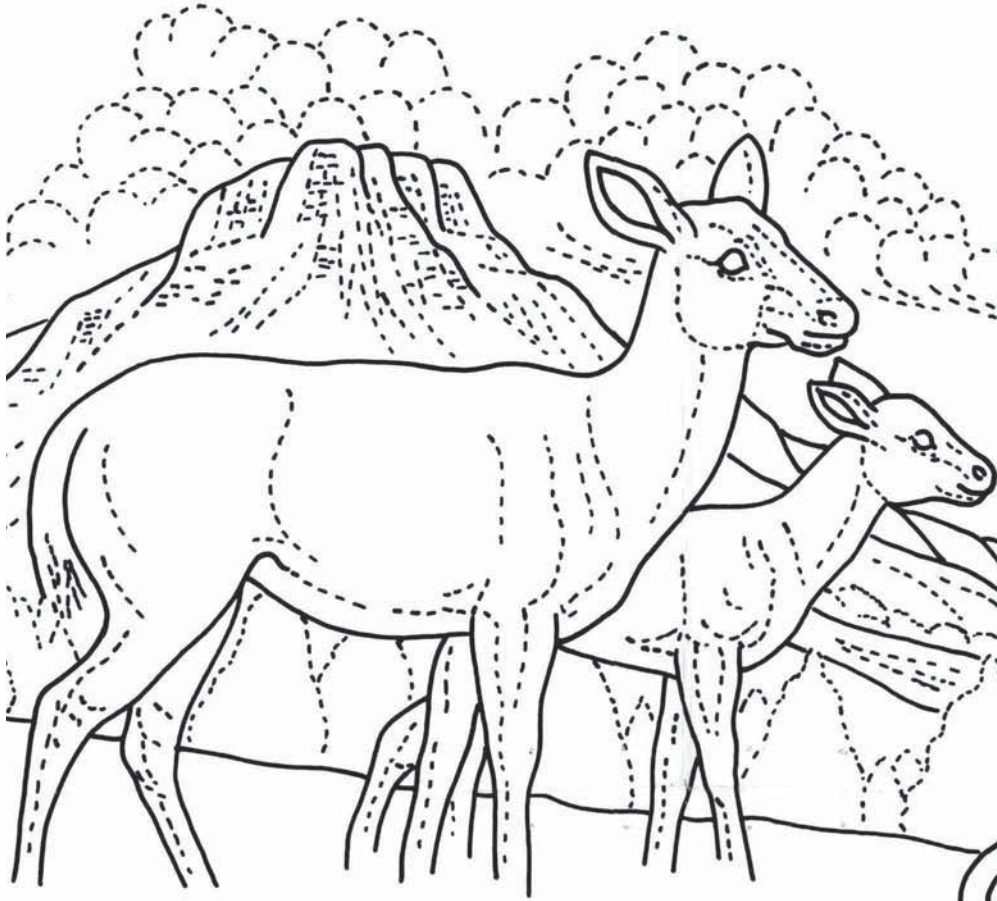

THIS AREA MAY BE USED FOR
ANY NUMBER OF SCENES OTHER
THAN THE DEER SHOWN.
USE YOUR IMAGINATION!



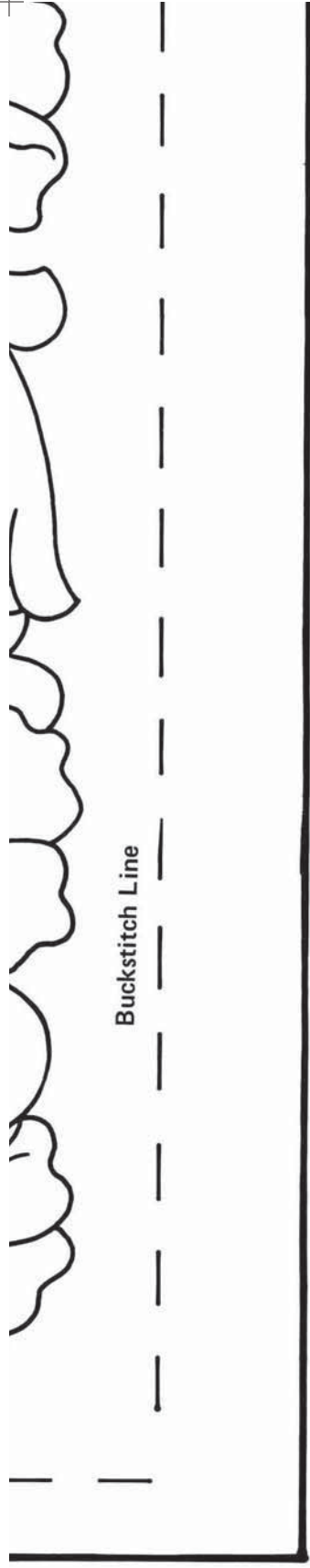



M882

H907

P217

J816

C429

V407

U853





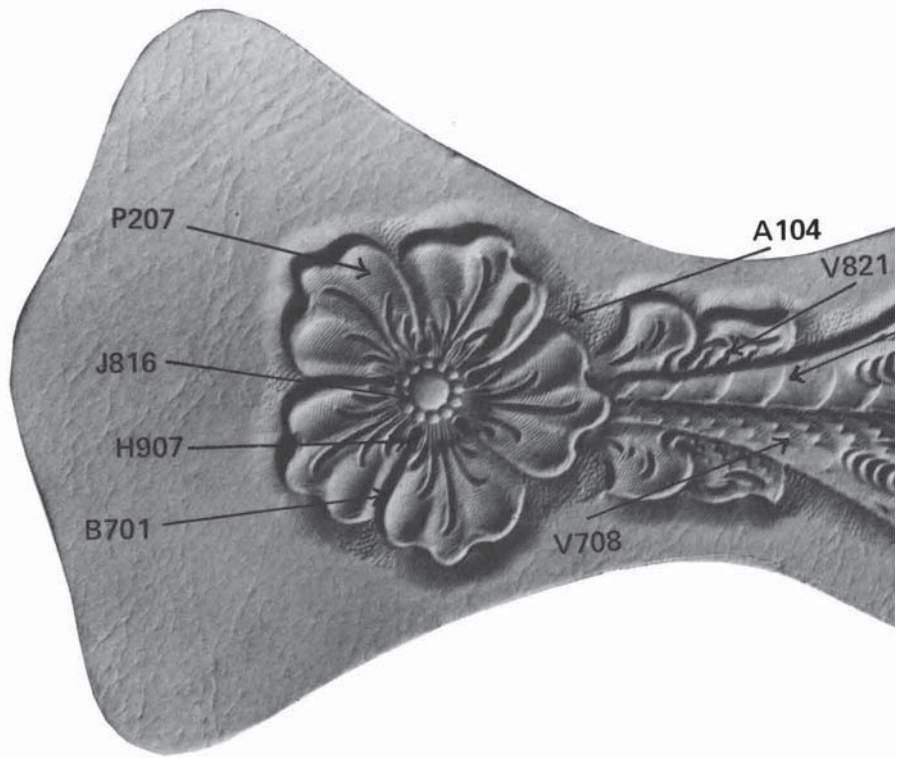

MARKET PLACE HANDBAG KIT NO. 4381

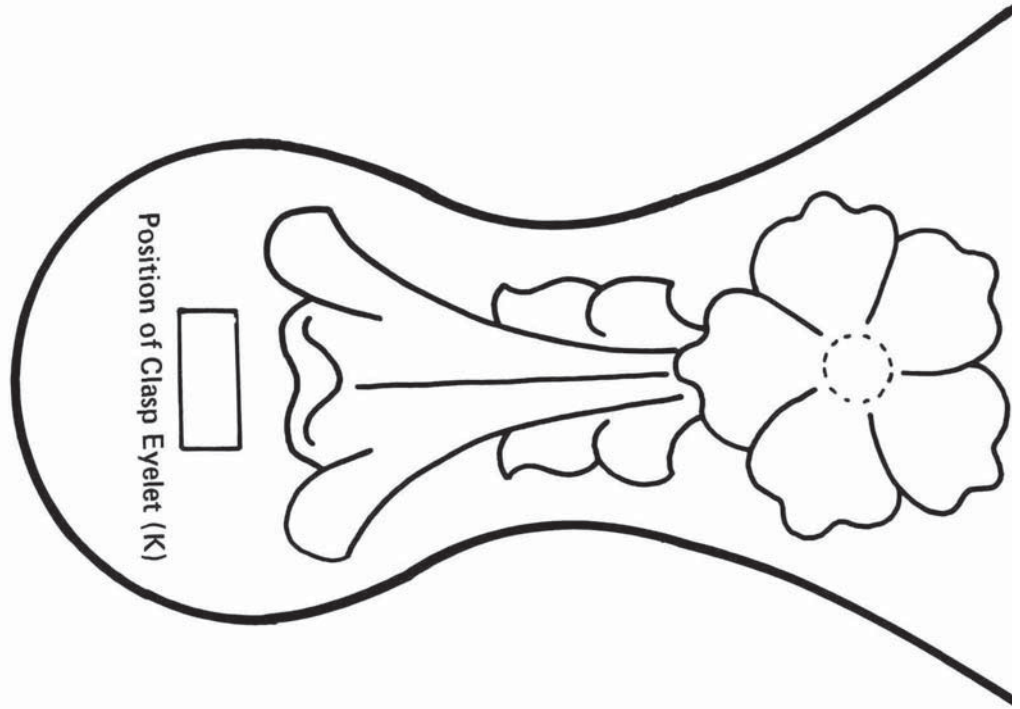

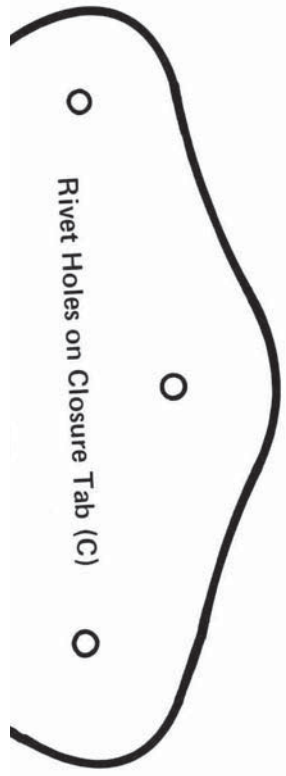
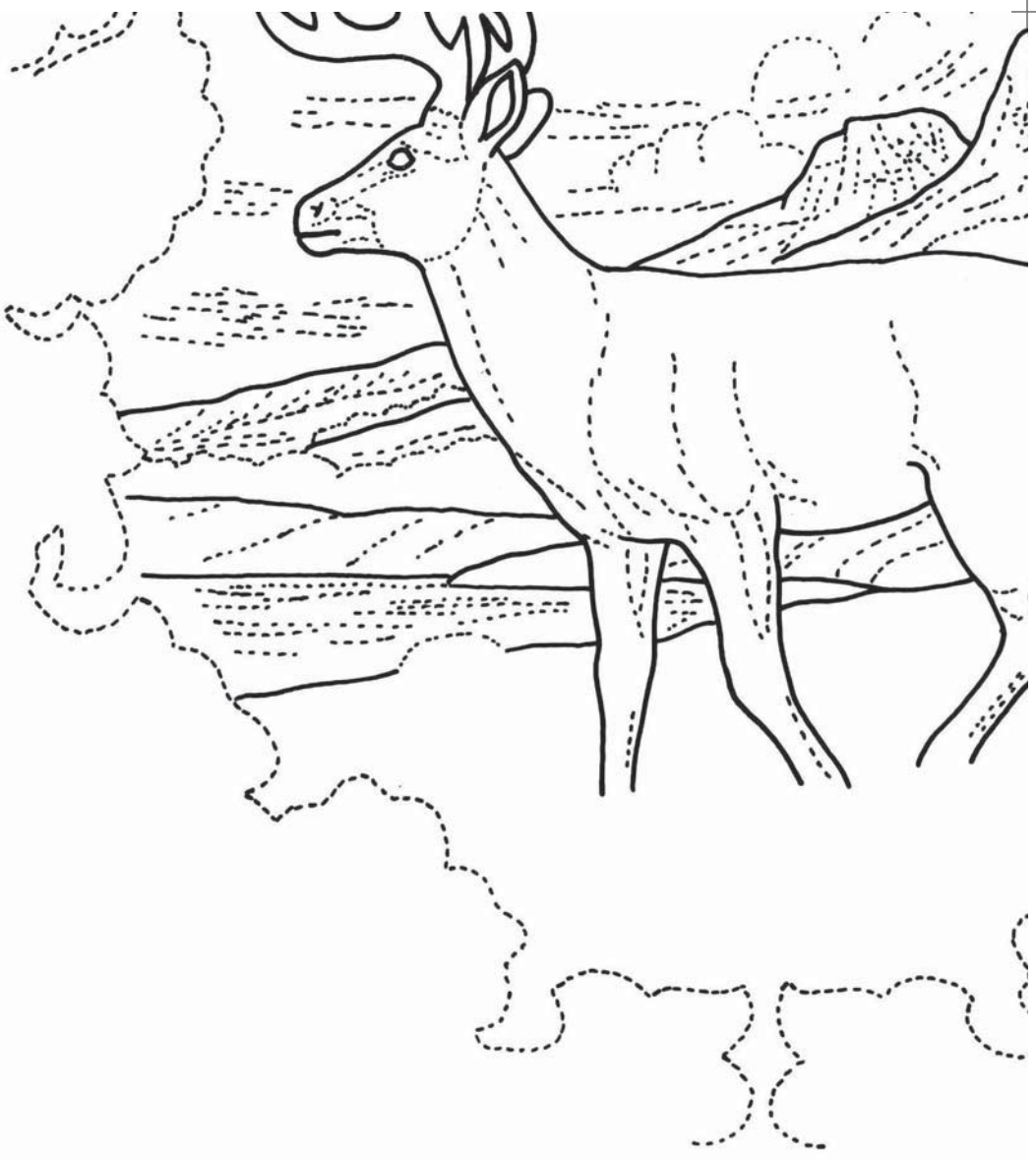

Rivet Holes on Closure Tab (C)



8036
Modeler

F980

F891

F934

F902

F918



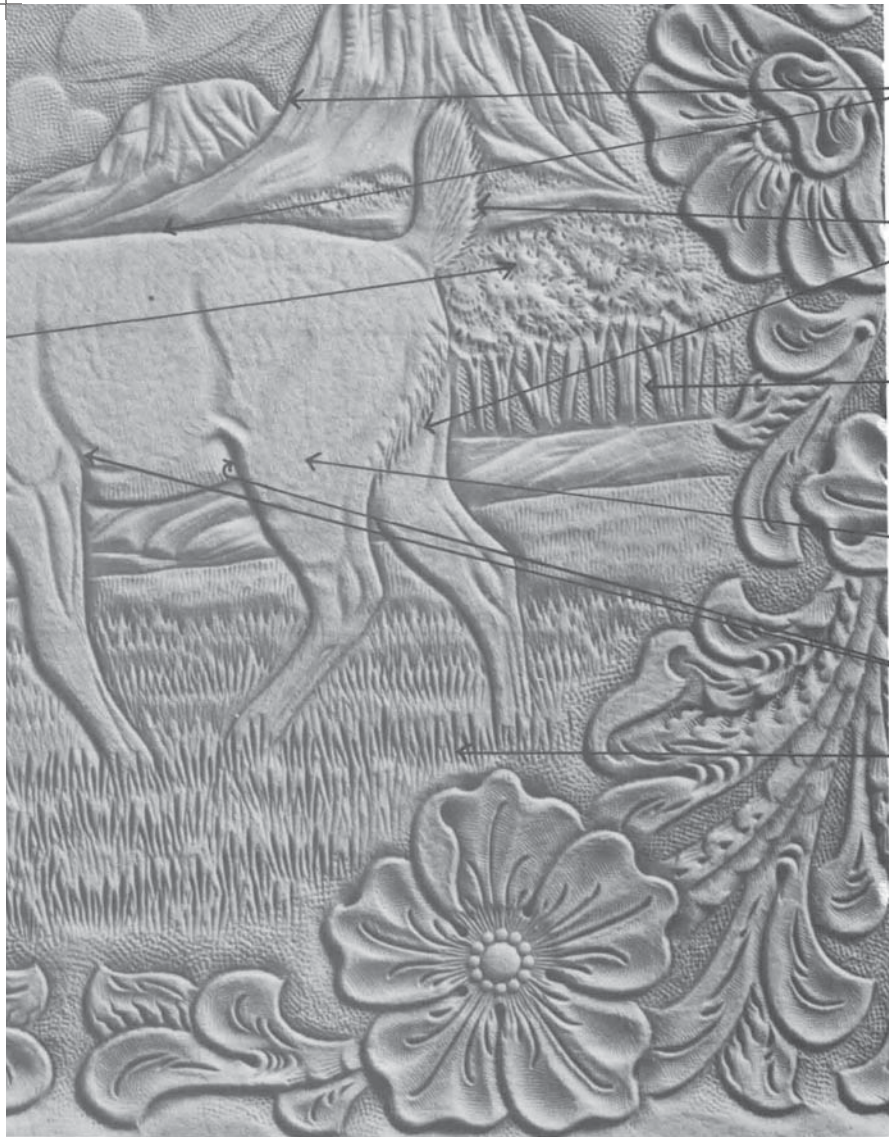

F897

F902

A104

8021-M
Hair Blade

F896

F916

Pattern by Kathleen Bond

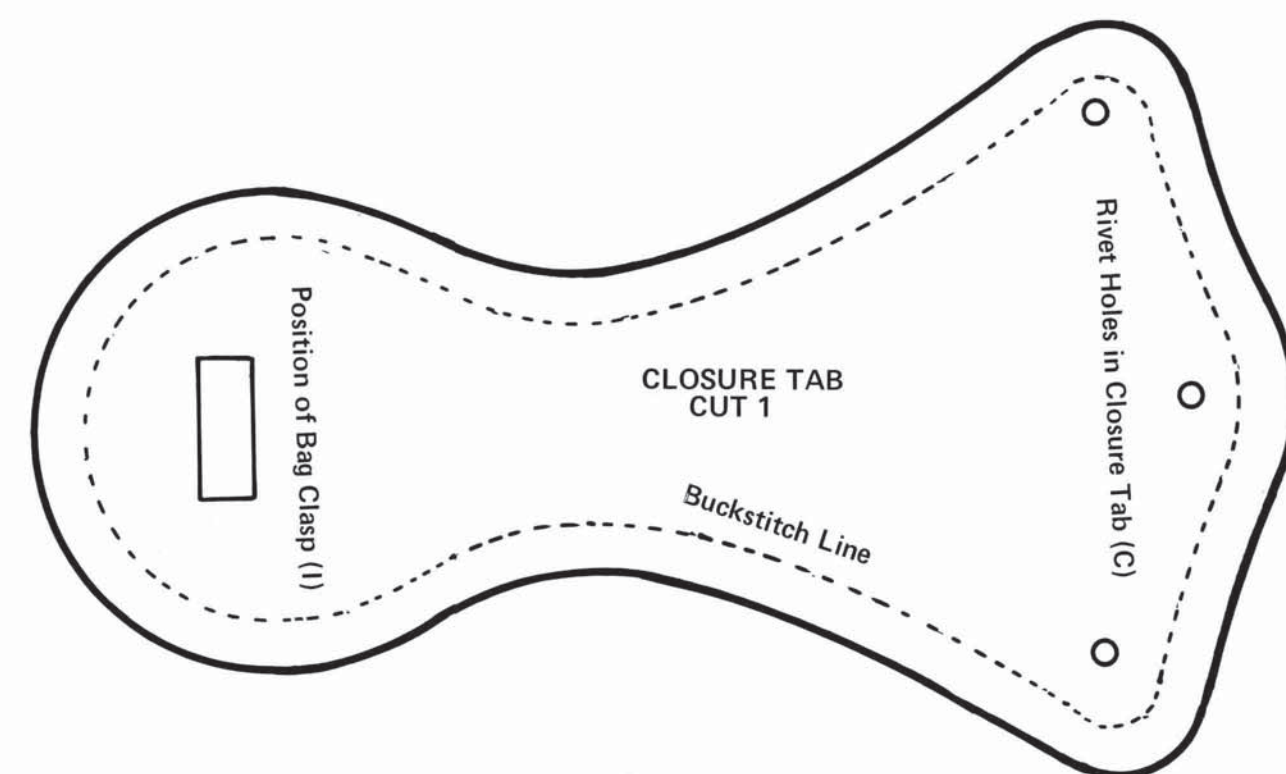
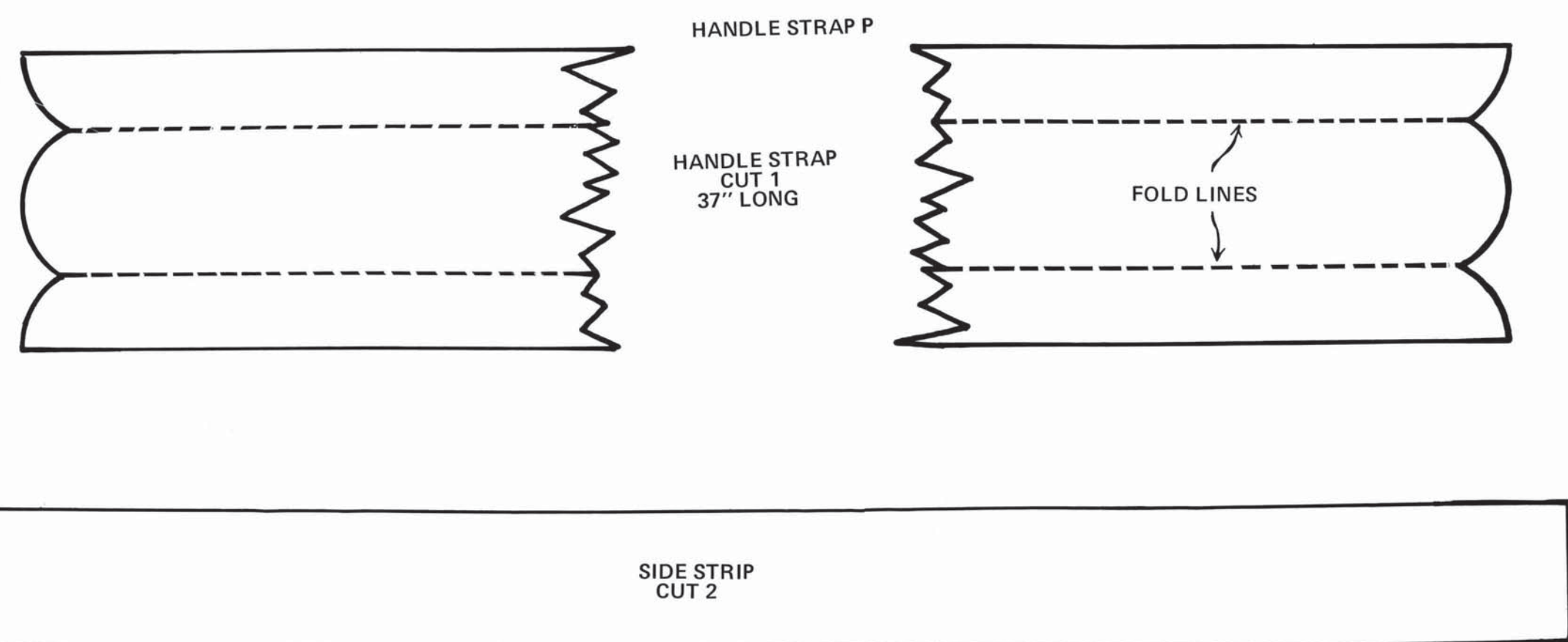
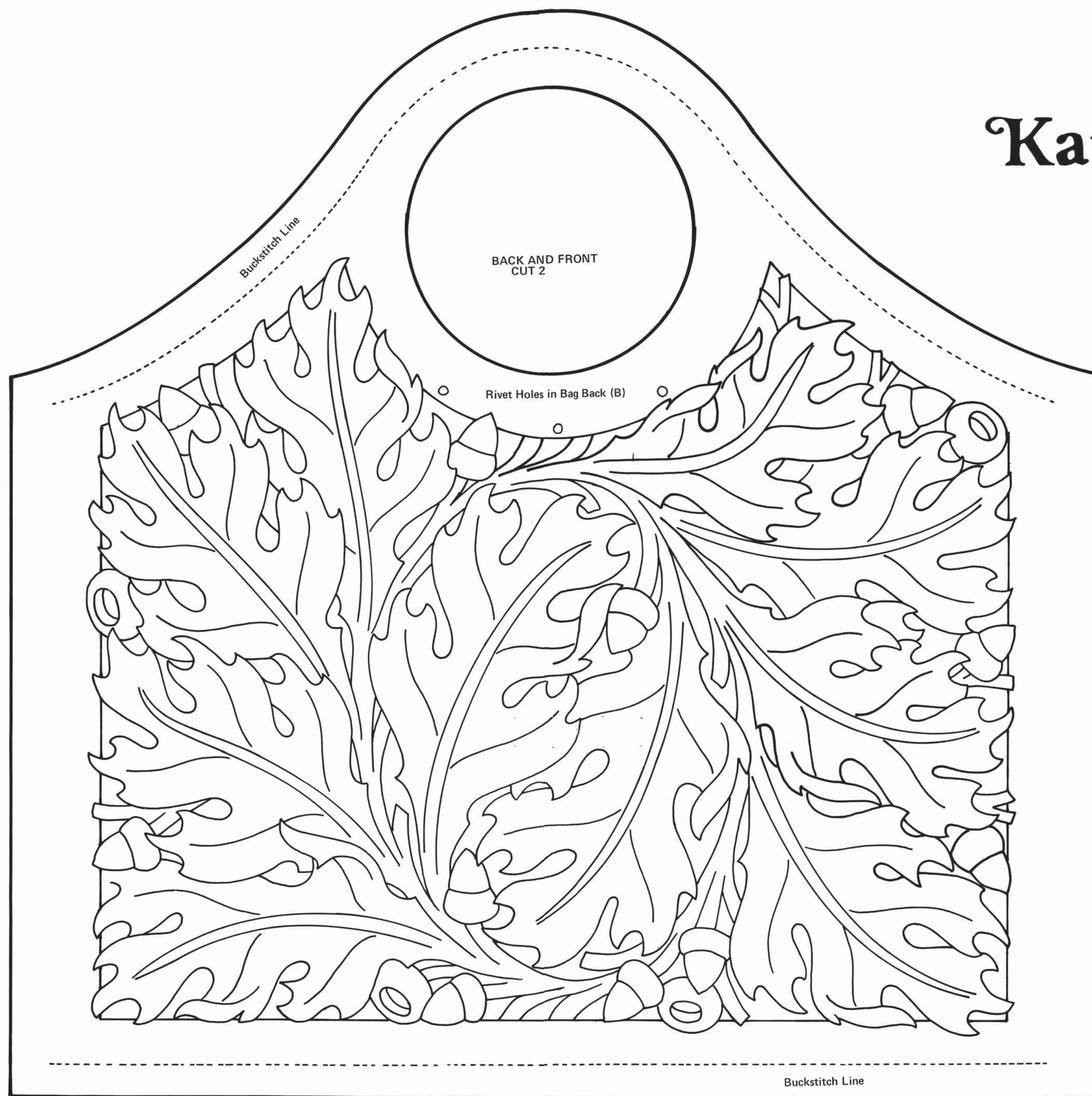

Buckstitch Line

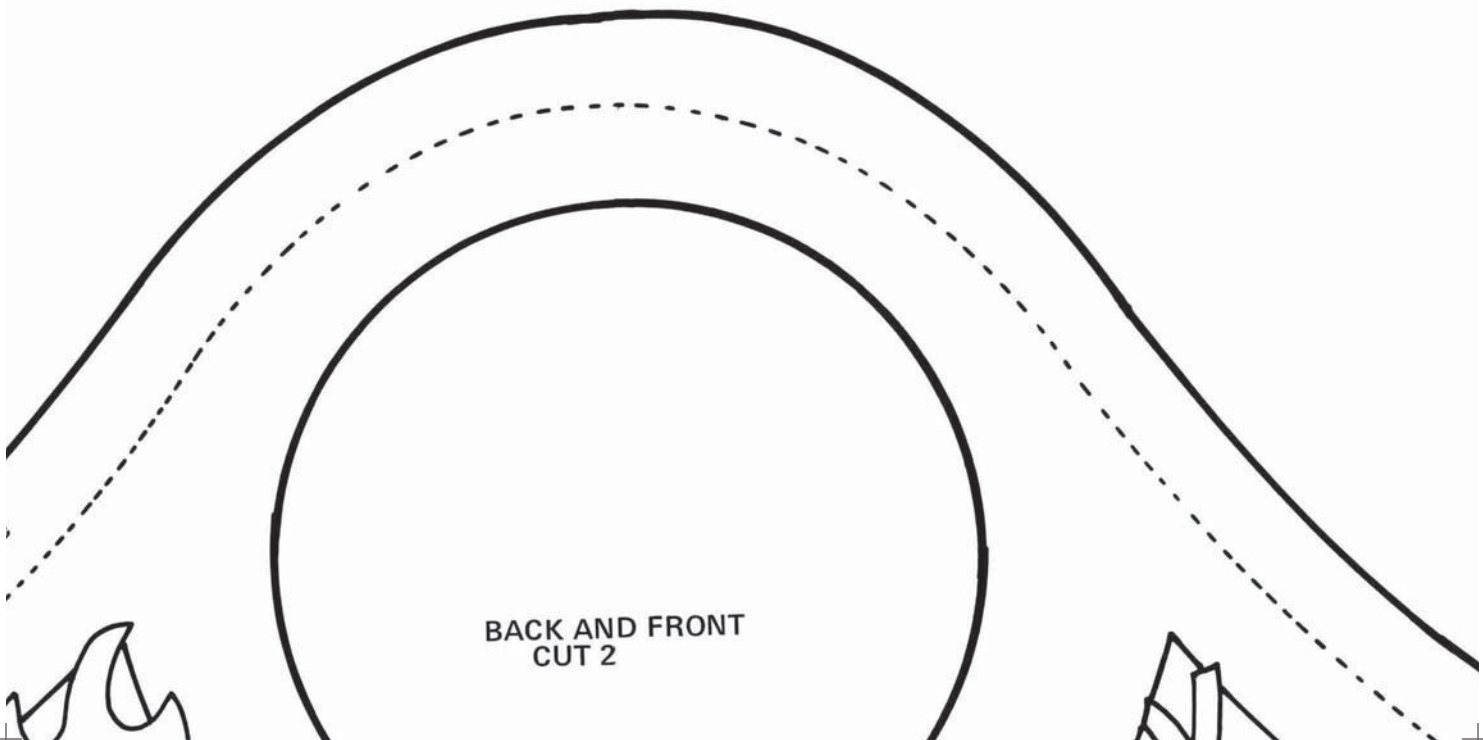

BACK AND FRONT
CUT 2

Pattern
by
Kathleen Bond









Rivet Holes in Bag Back (B)

Buckstitch Line

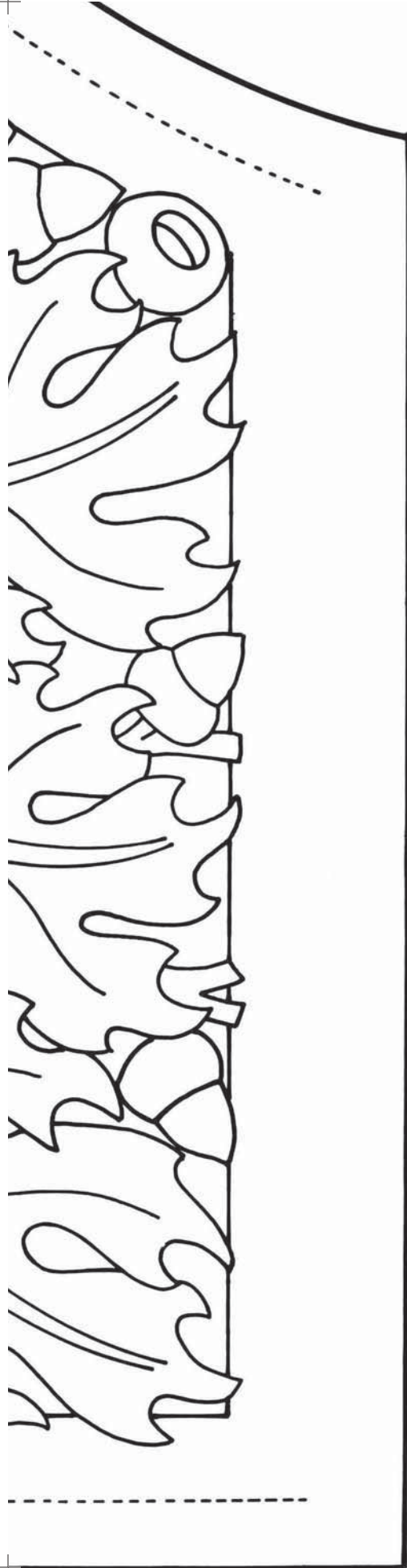



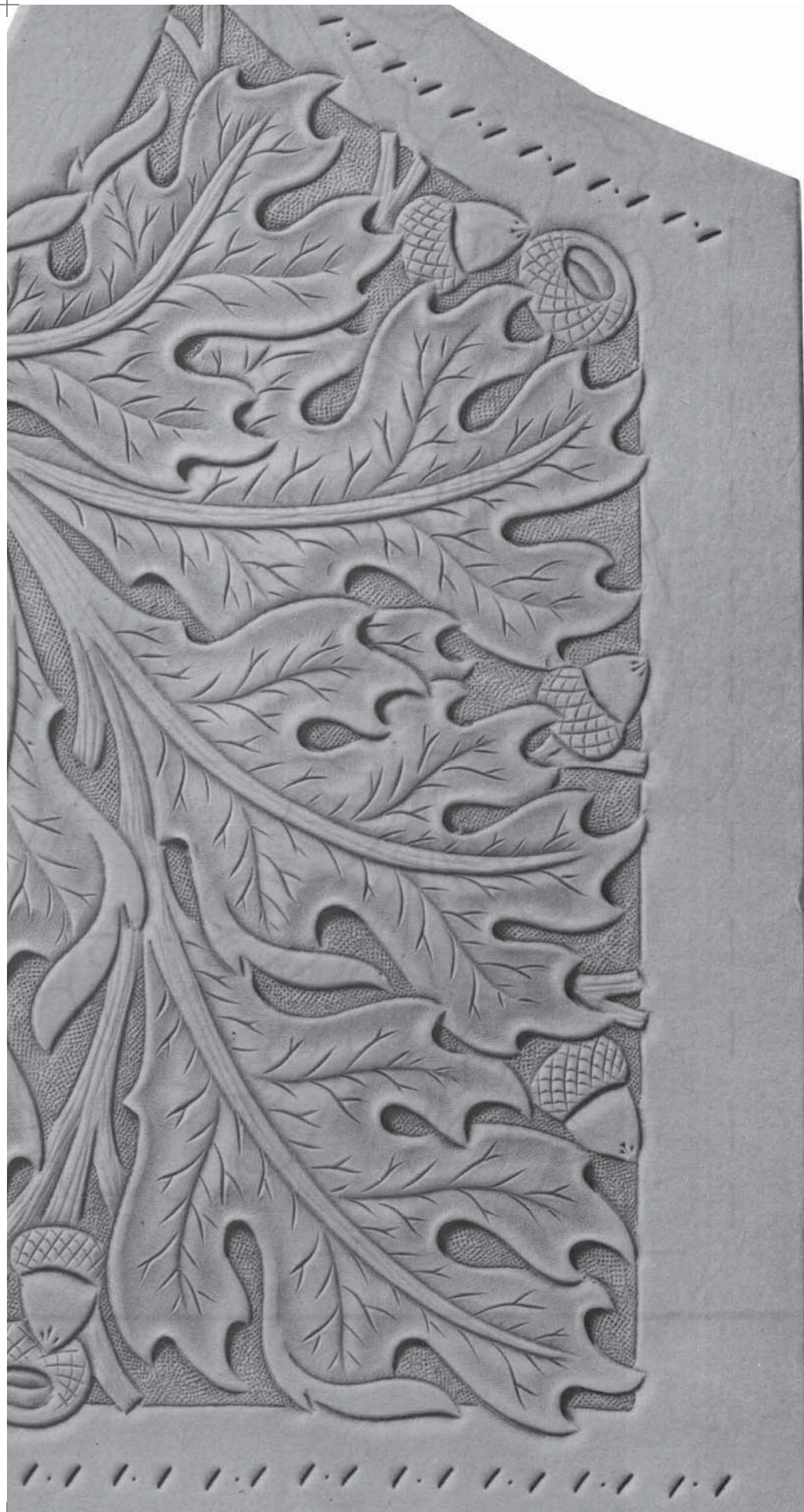

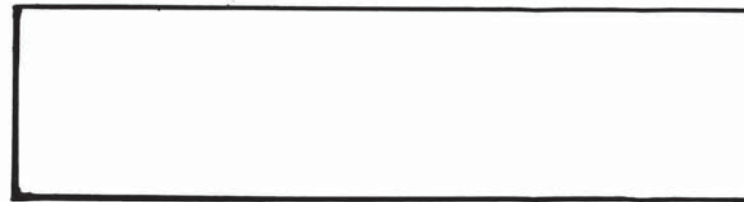
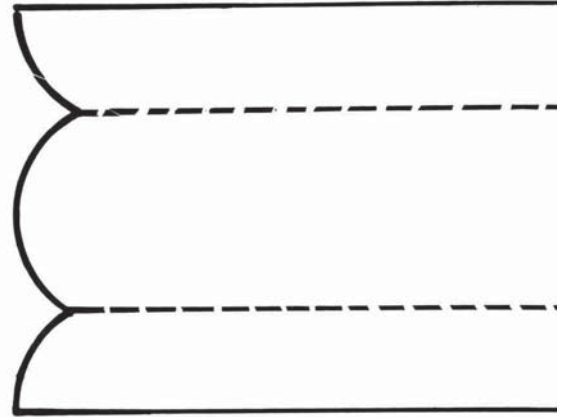

MARKET PLACE HANDBAG KIT NO. 4381

HANDLE STRAP P

HANDLE STRAP
CUT 1
37" LONG

FOLD LINES

SIDE STRIP
CUT 2

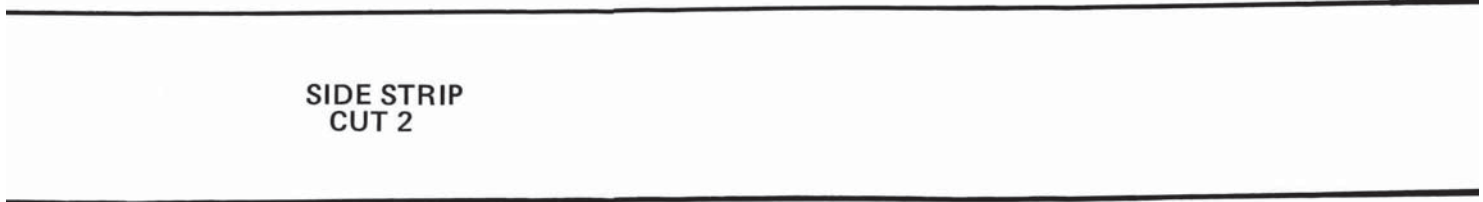
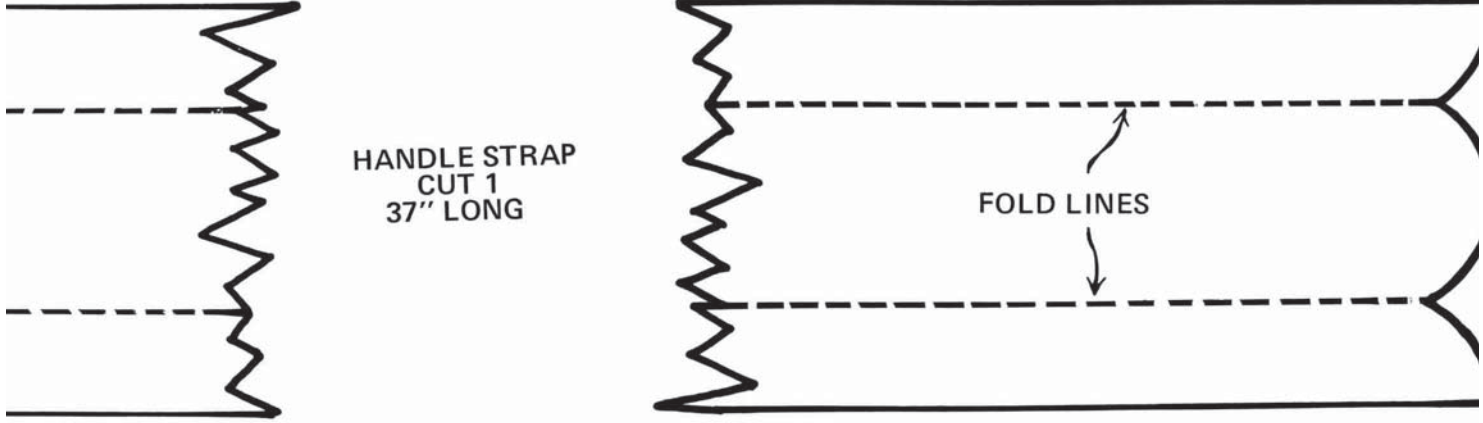

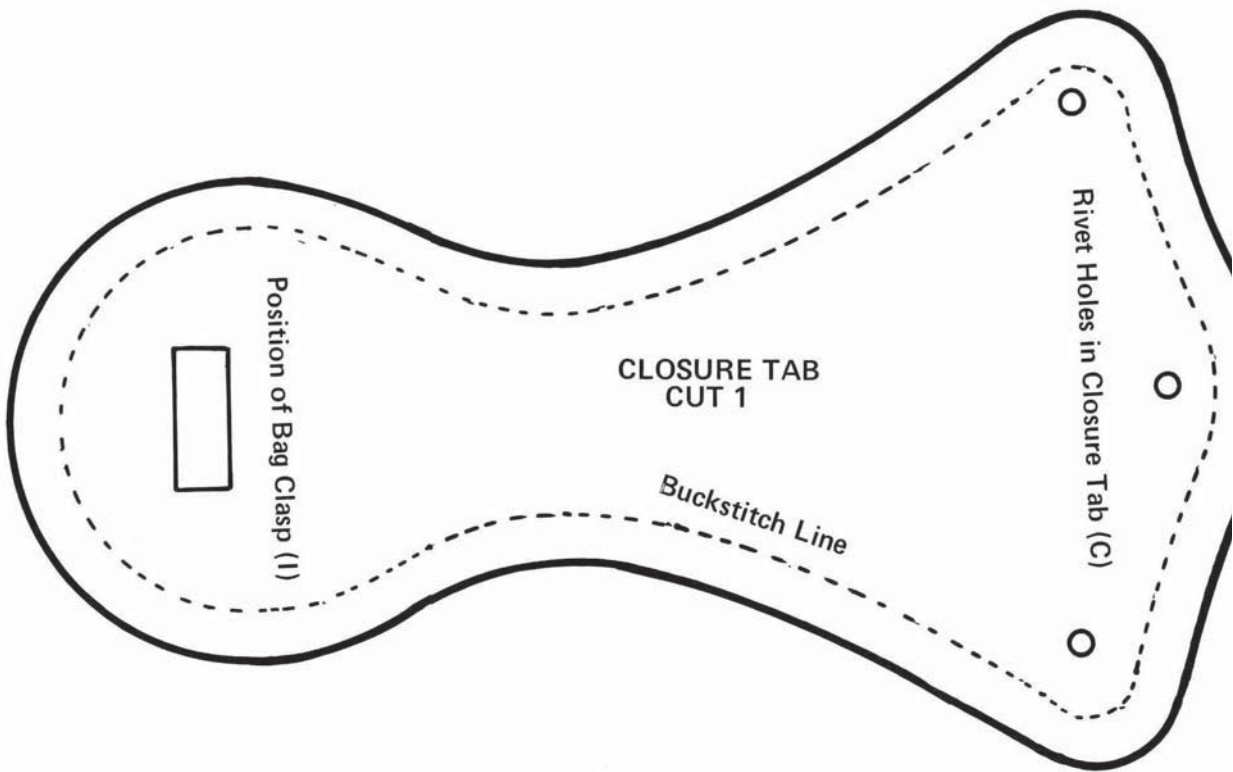

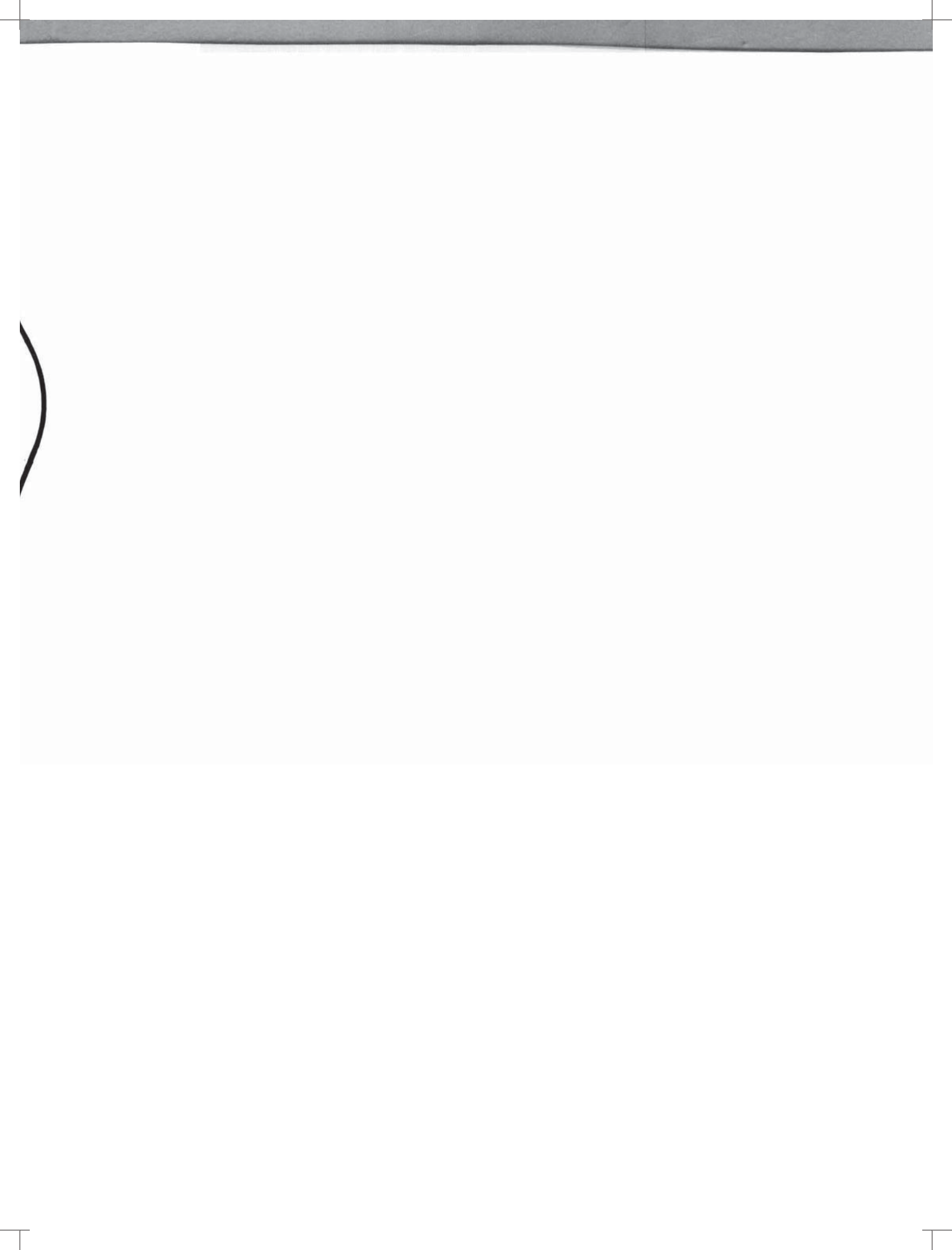



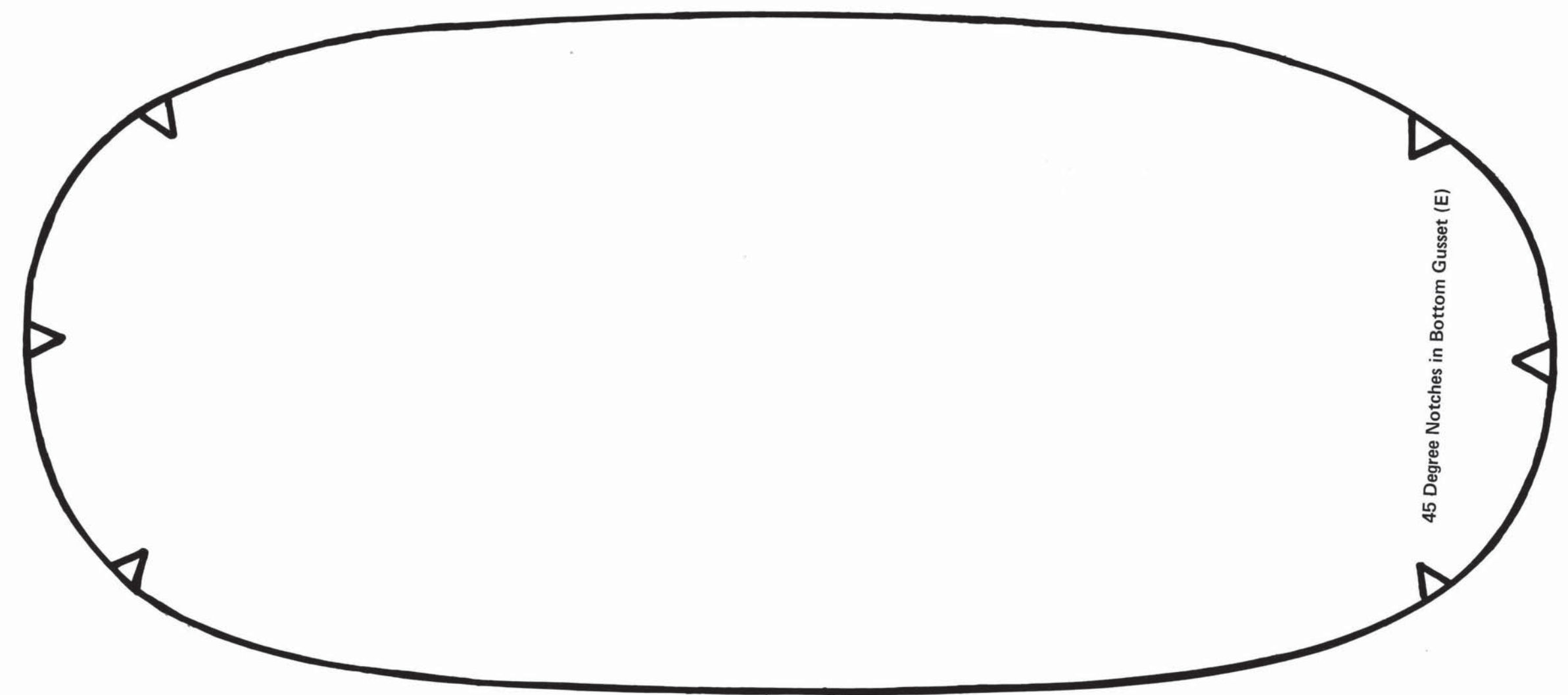
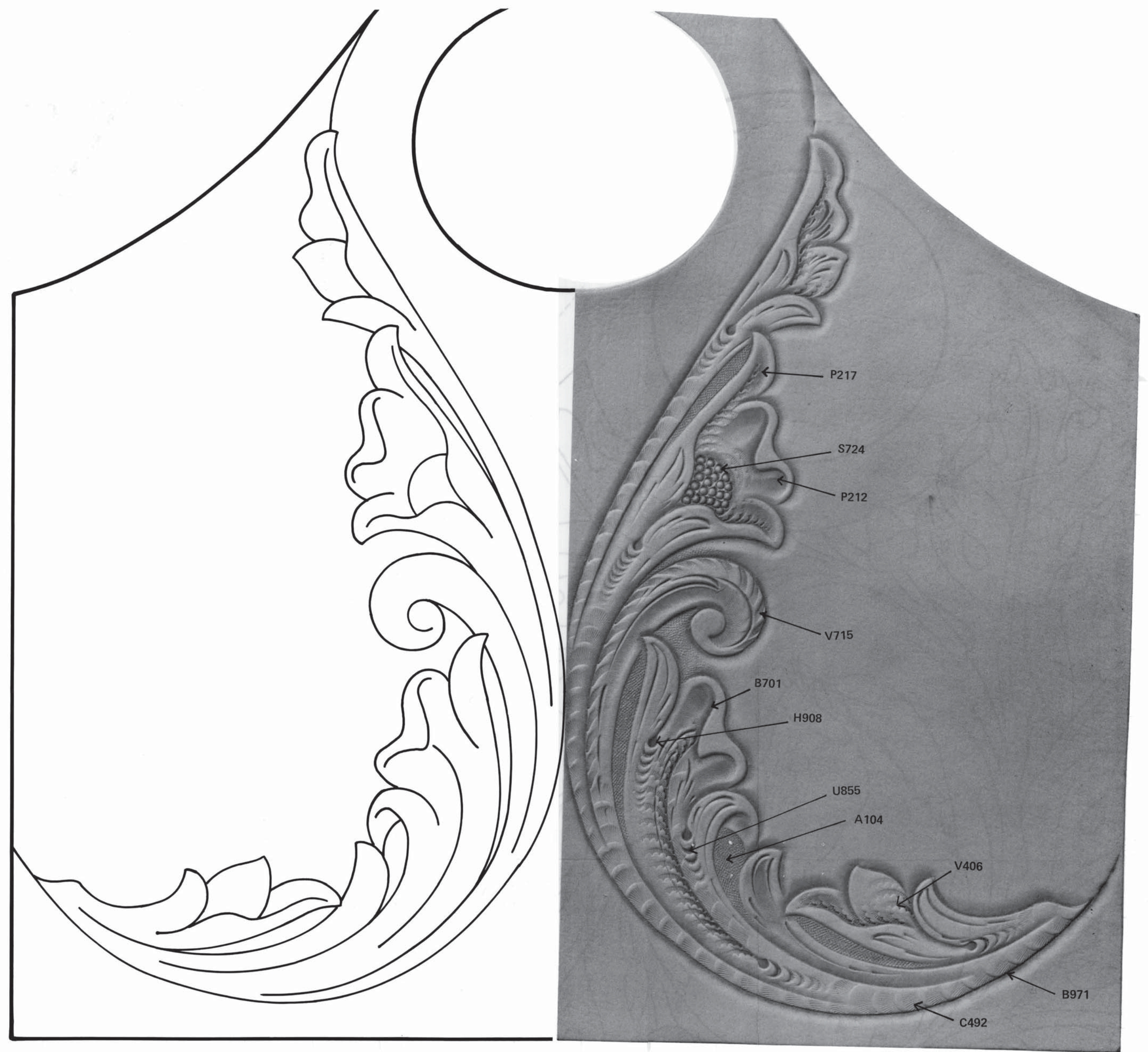
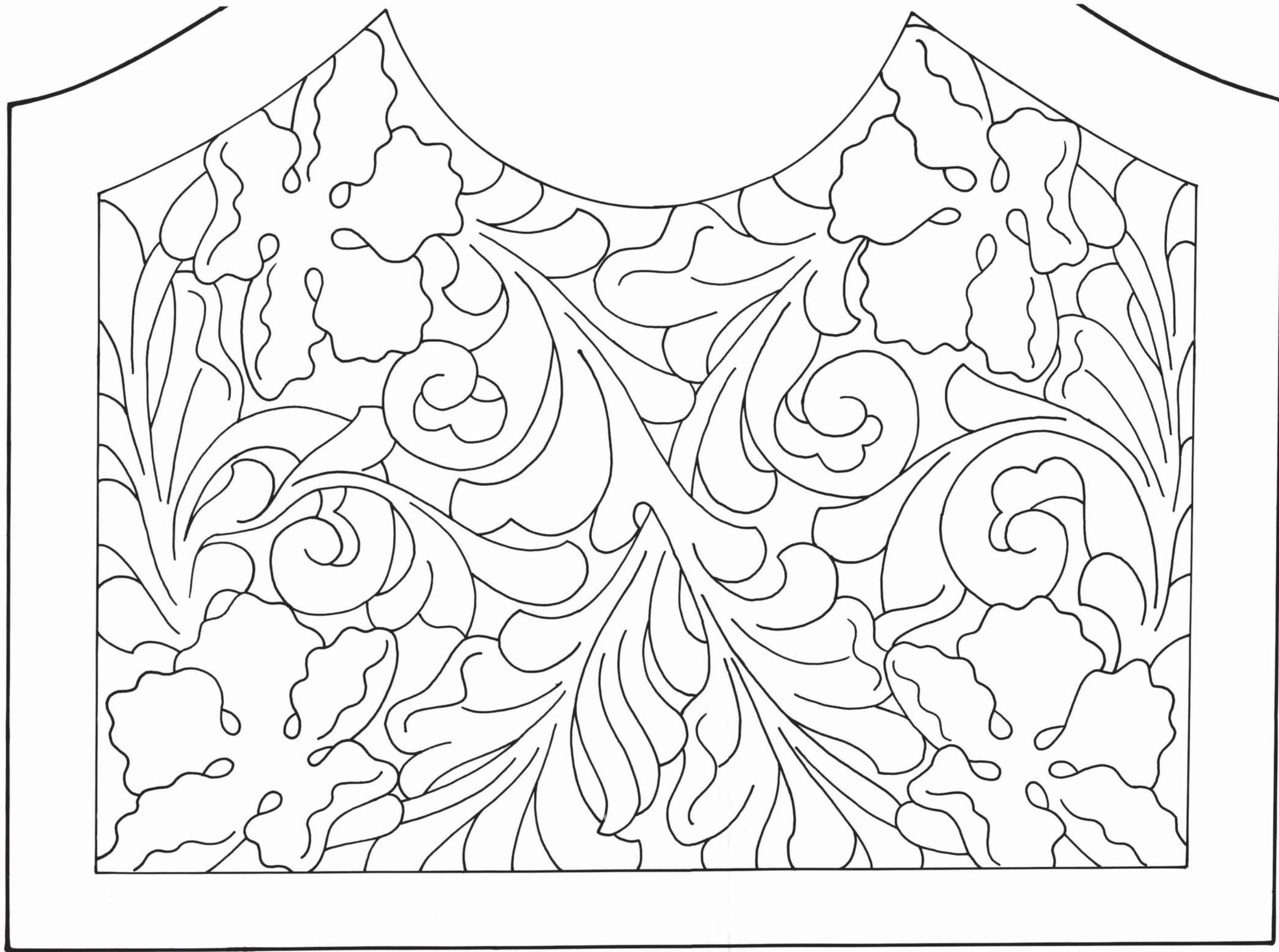

BOTTOM GUSSET
CUT 1

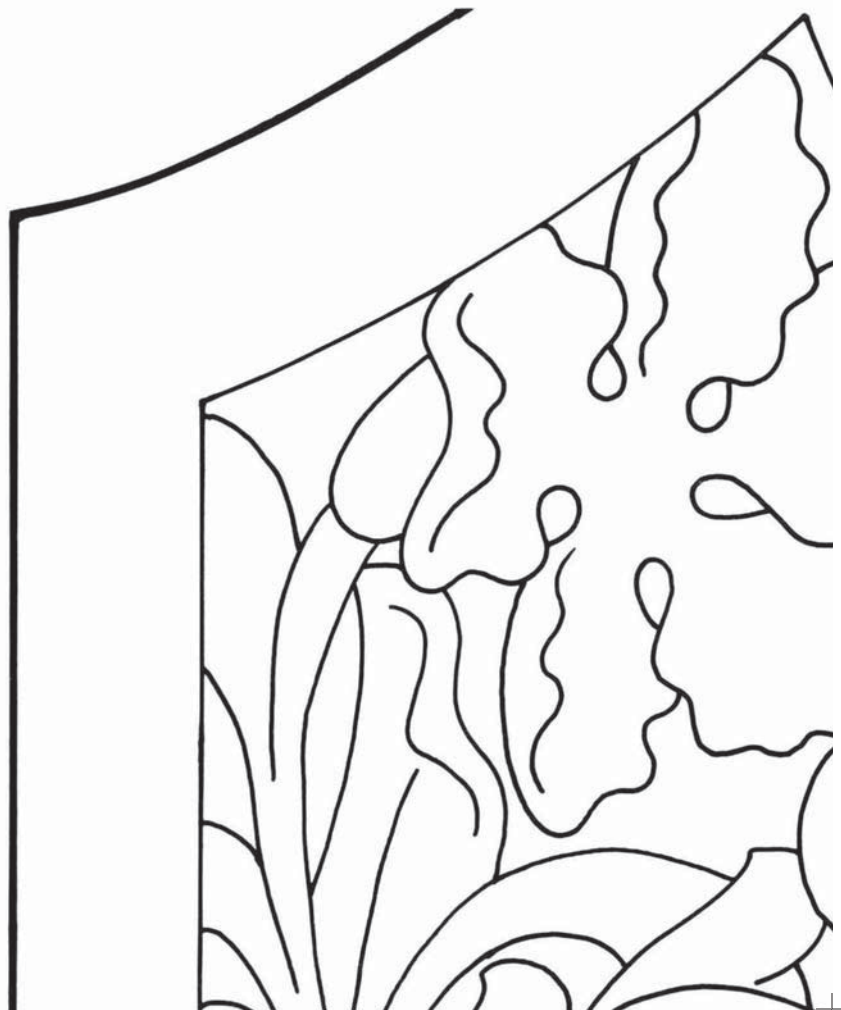



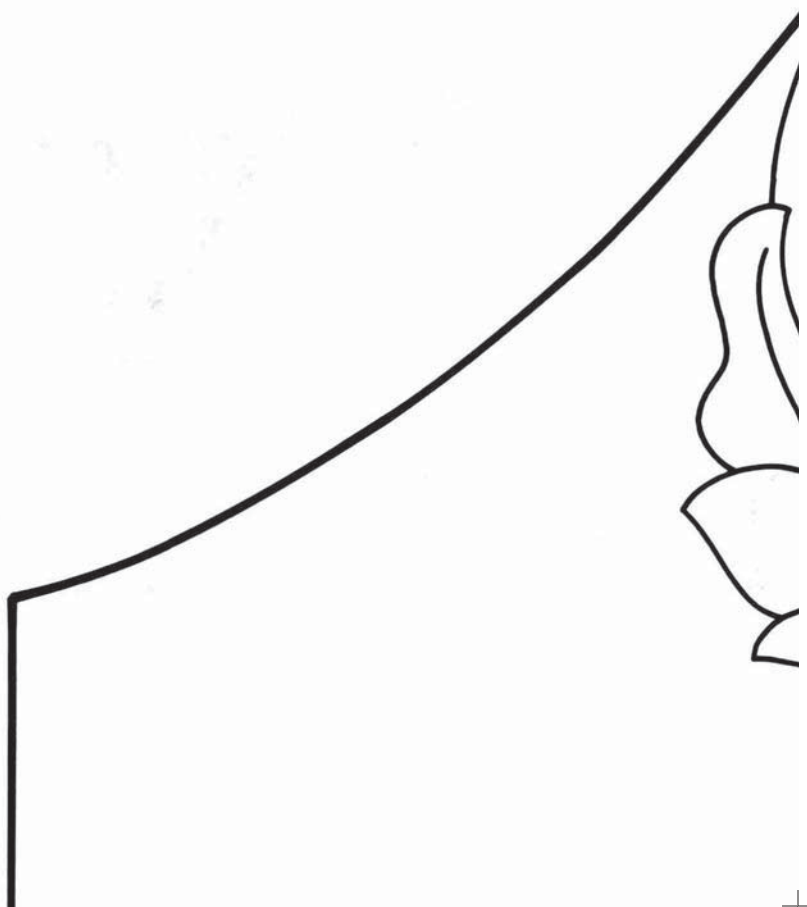
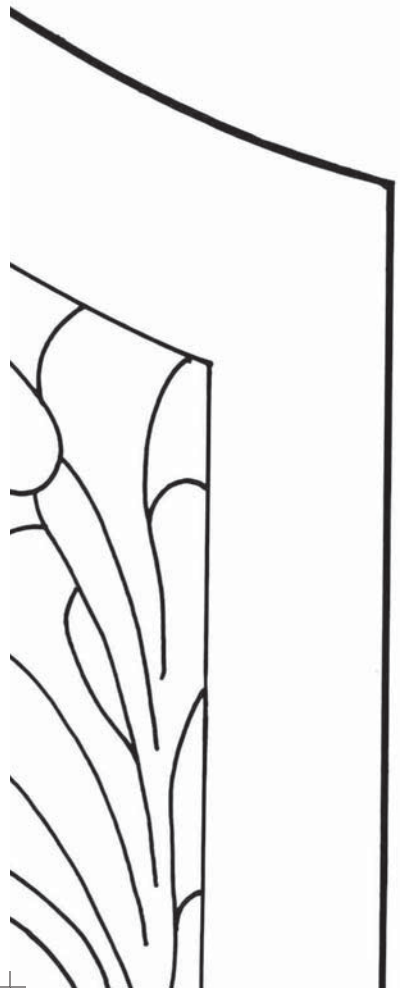

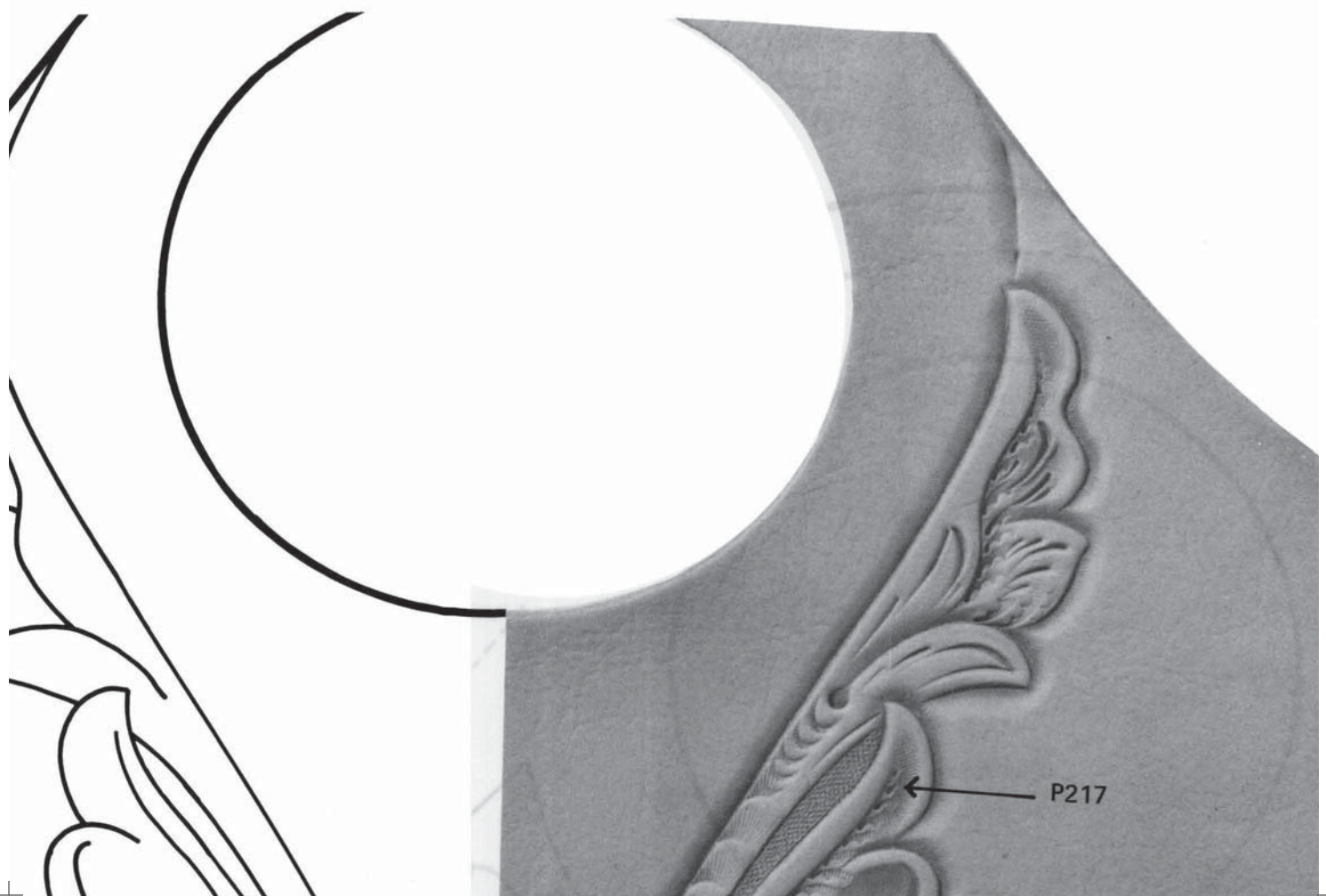

P217



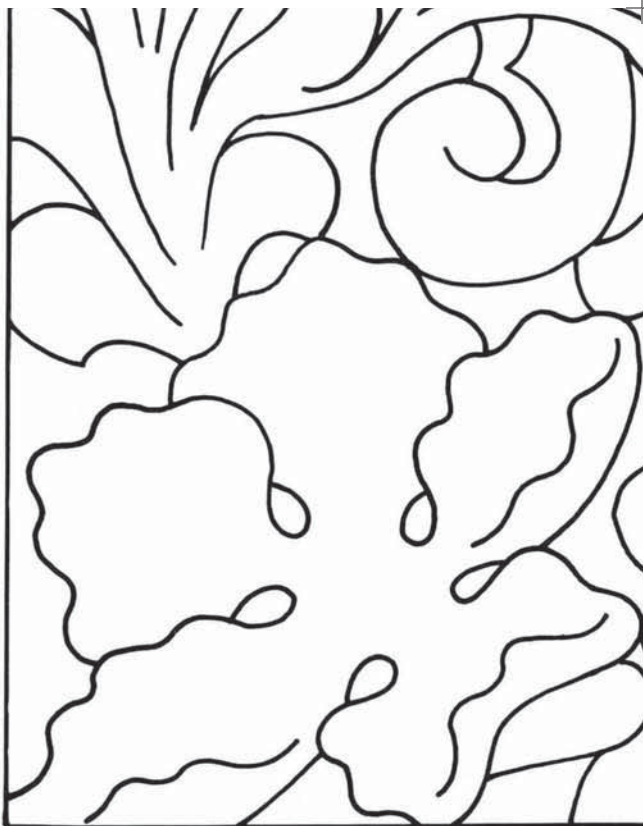

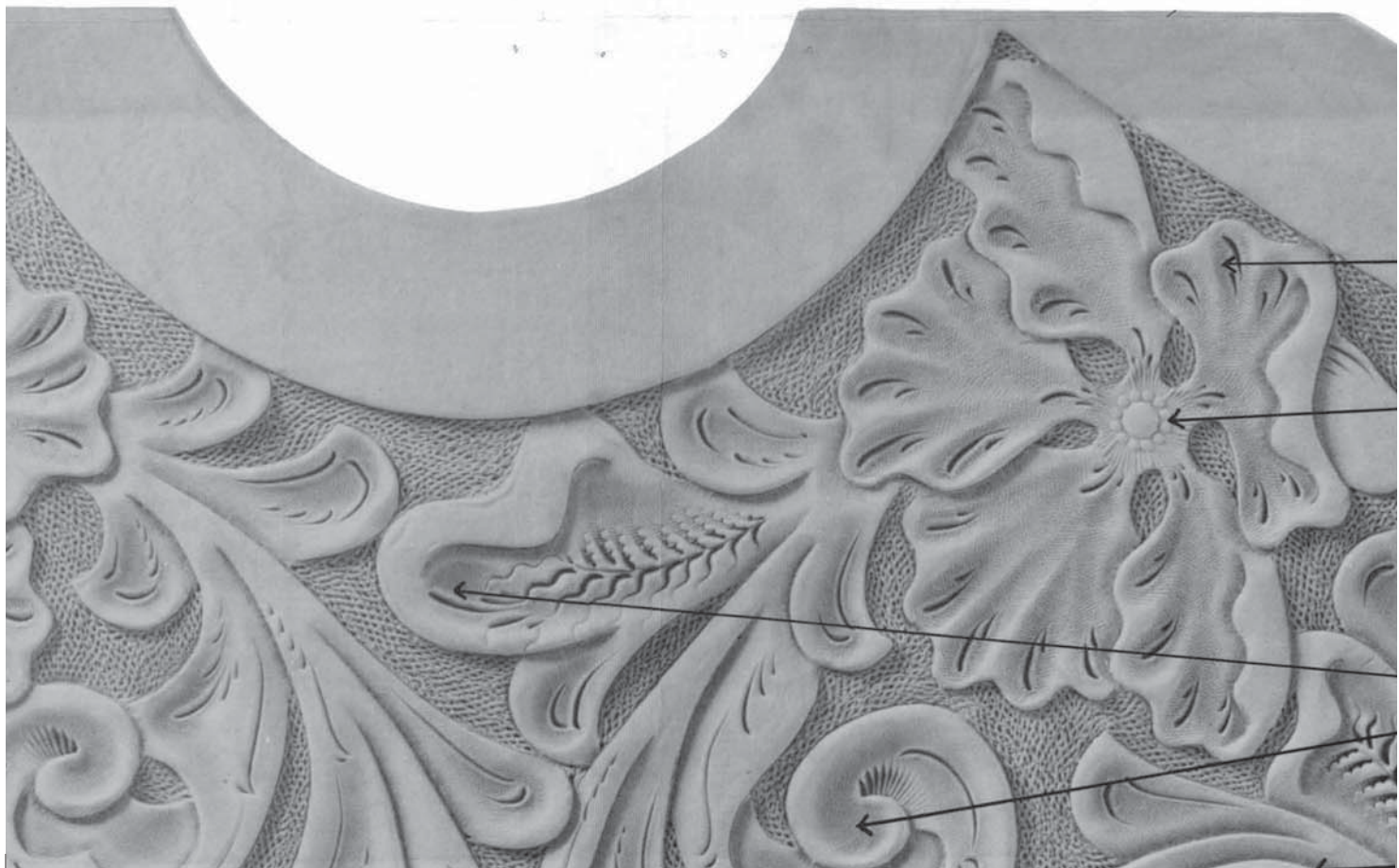

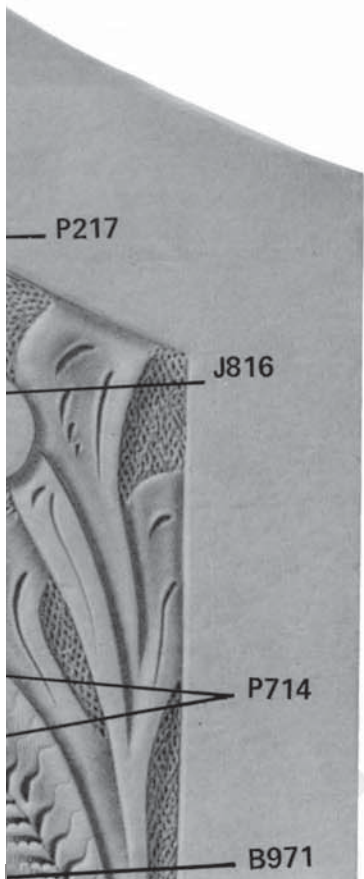
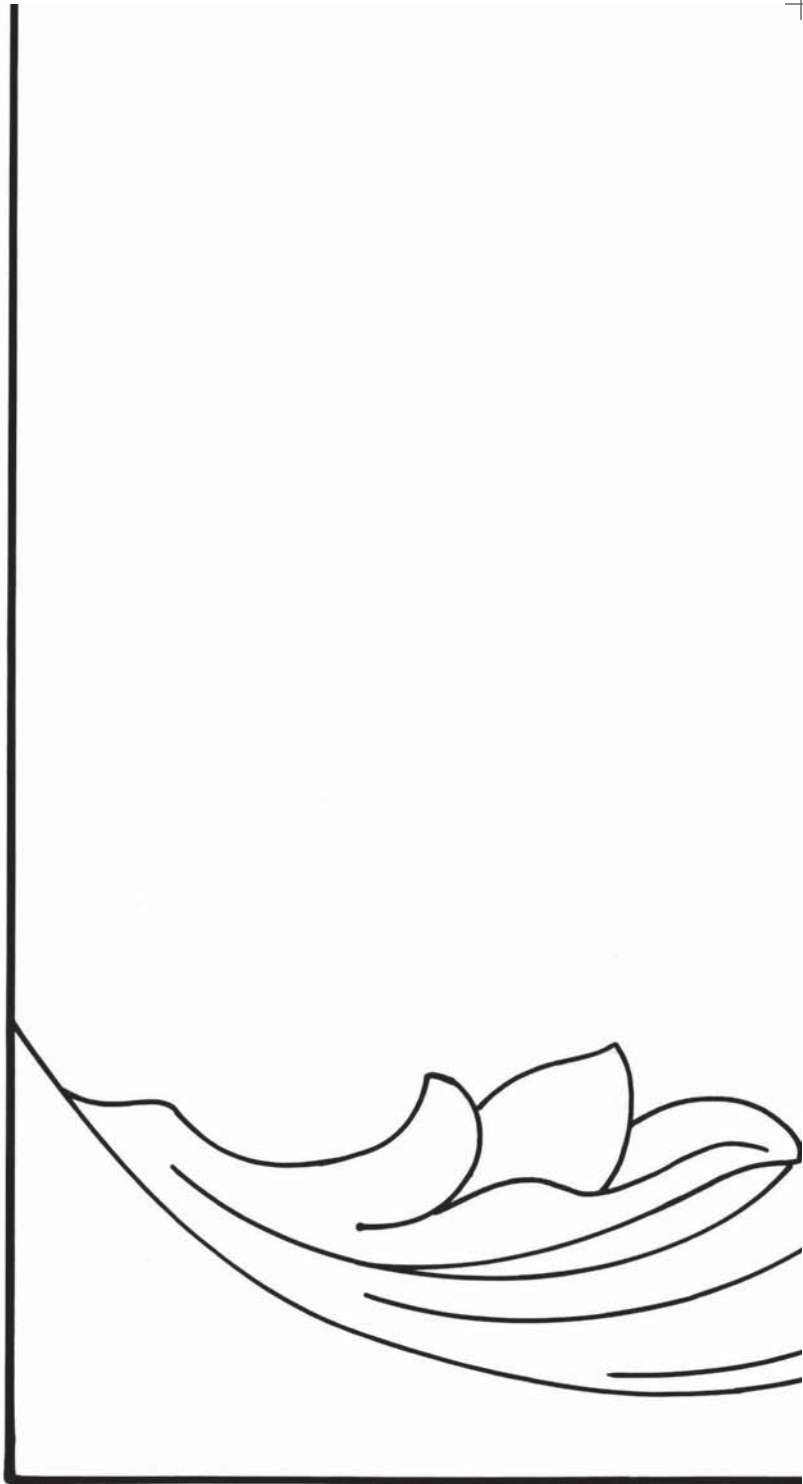

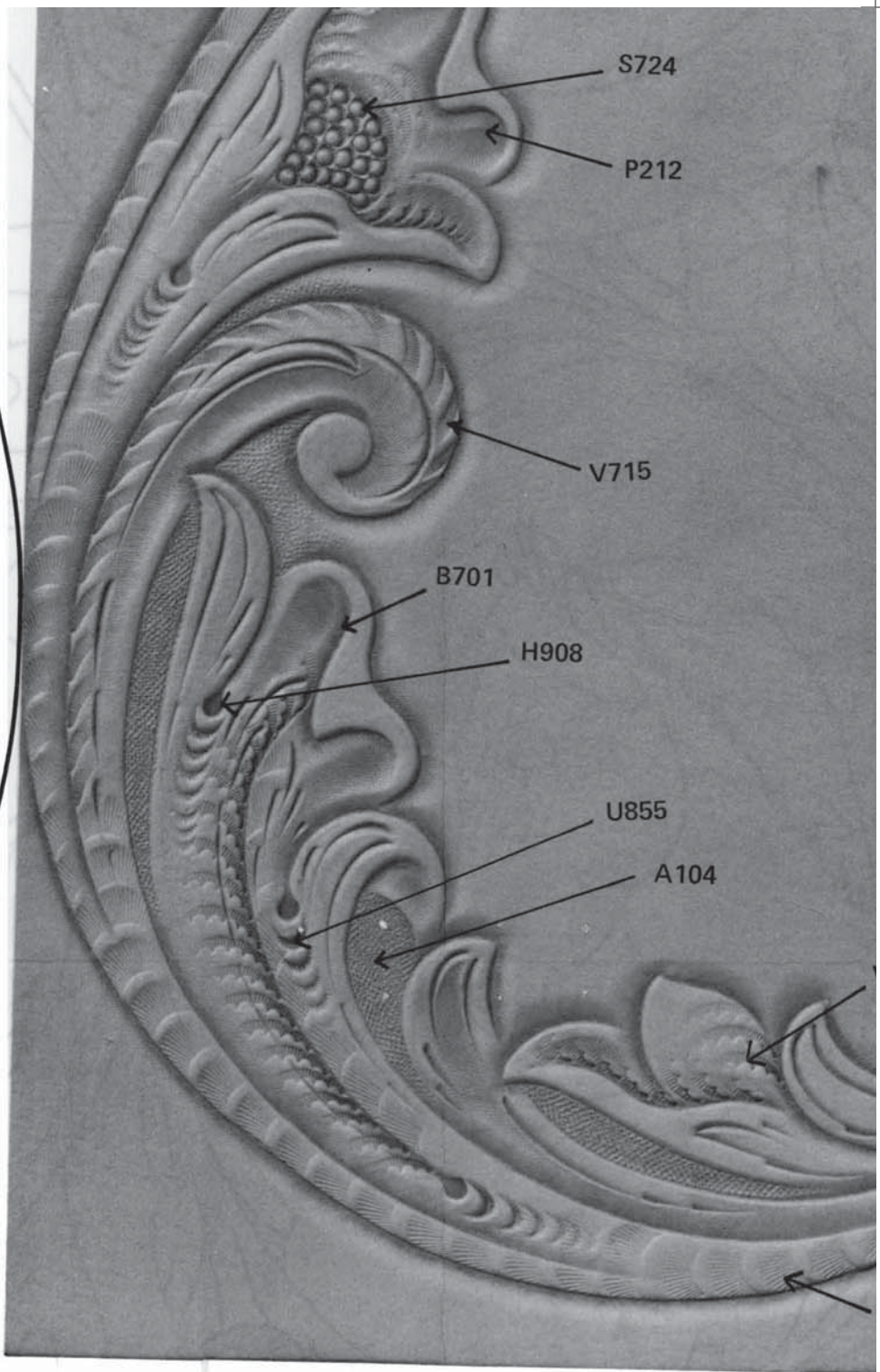
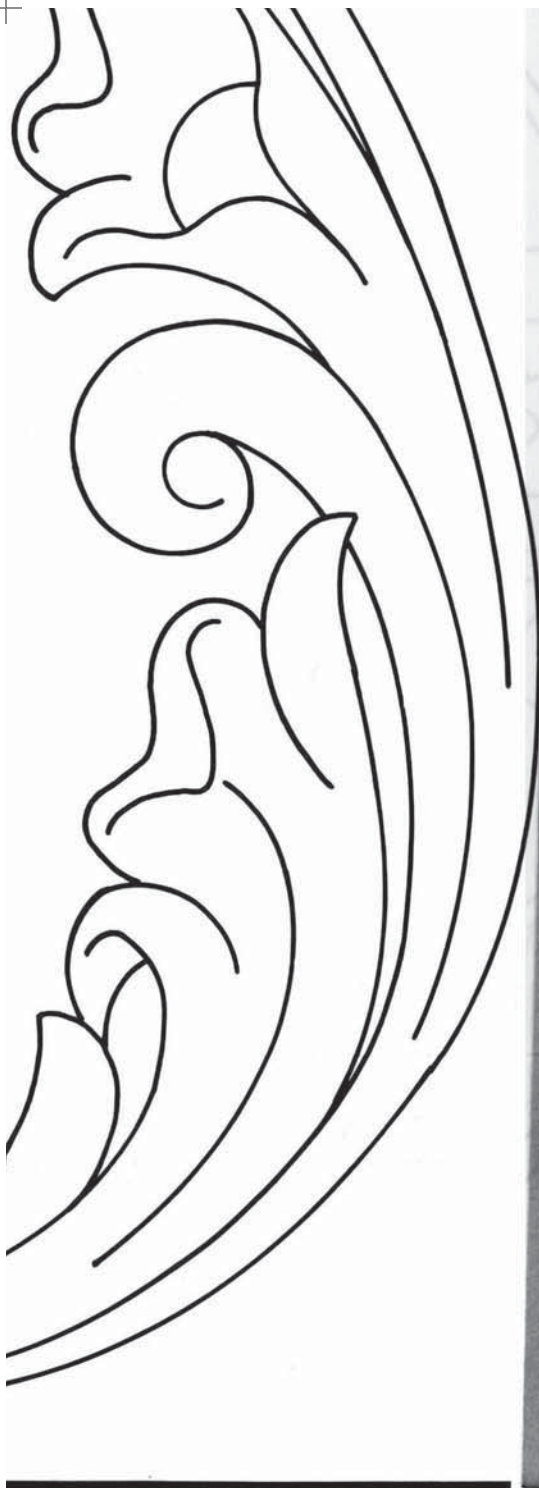

V406

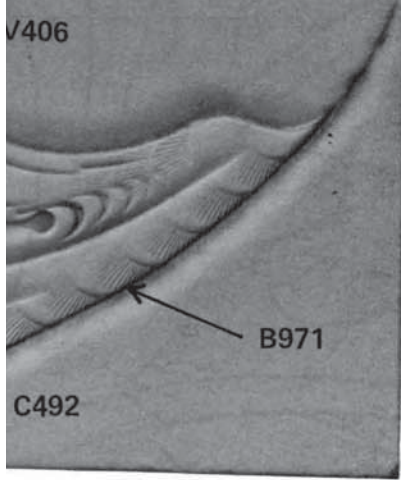

B971

C492







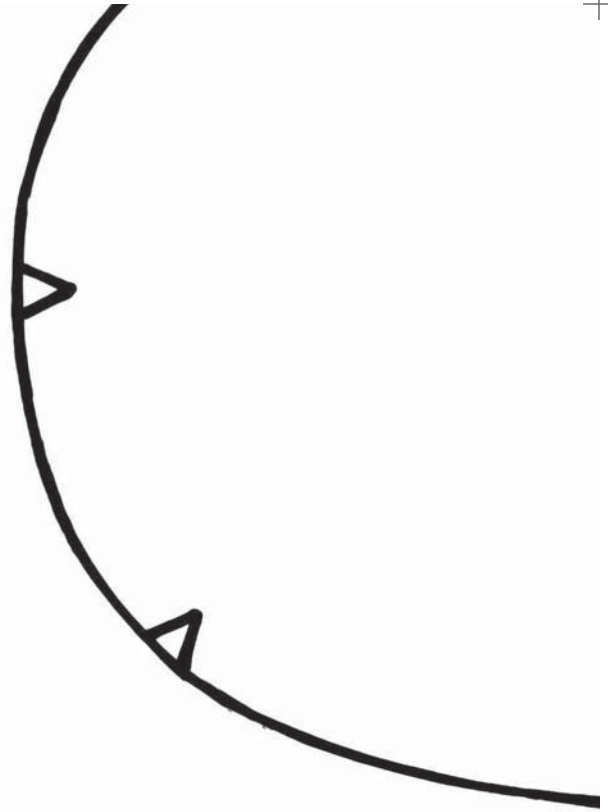
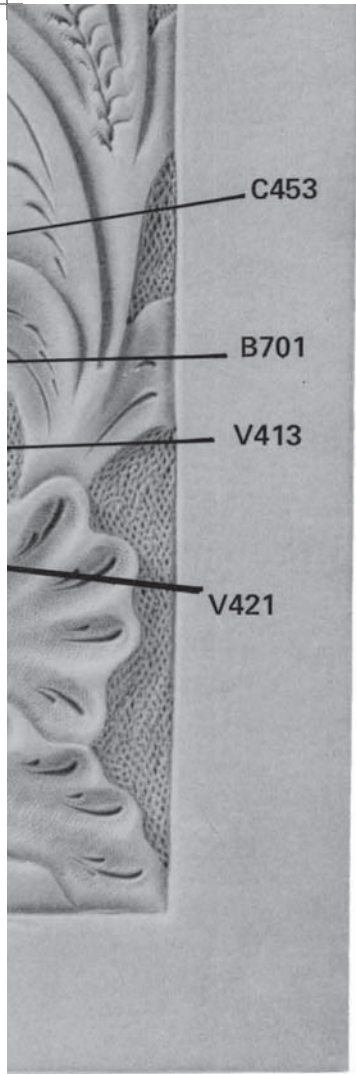



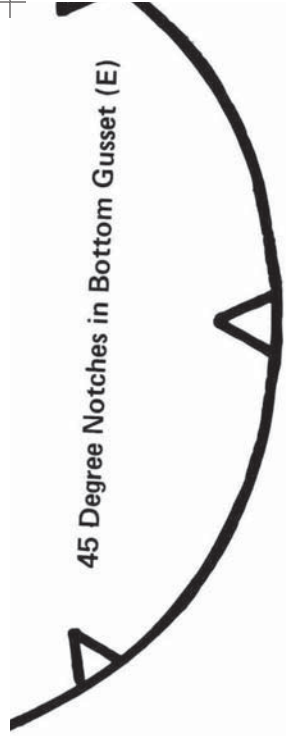

**BOTTOM GUSSET
CUT 1**

MARKET PLACE HANDBAG KIT NO. 4381

Pattern by Kathleen Bond



THIS AREA MAY BE USED FOR
ANY NUMBER OF SCENES OTHER
THAN THE HORSES SHOWN.
USE YOUR IMAGINATION!



Bur

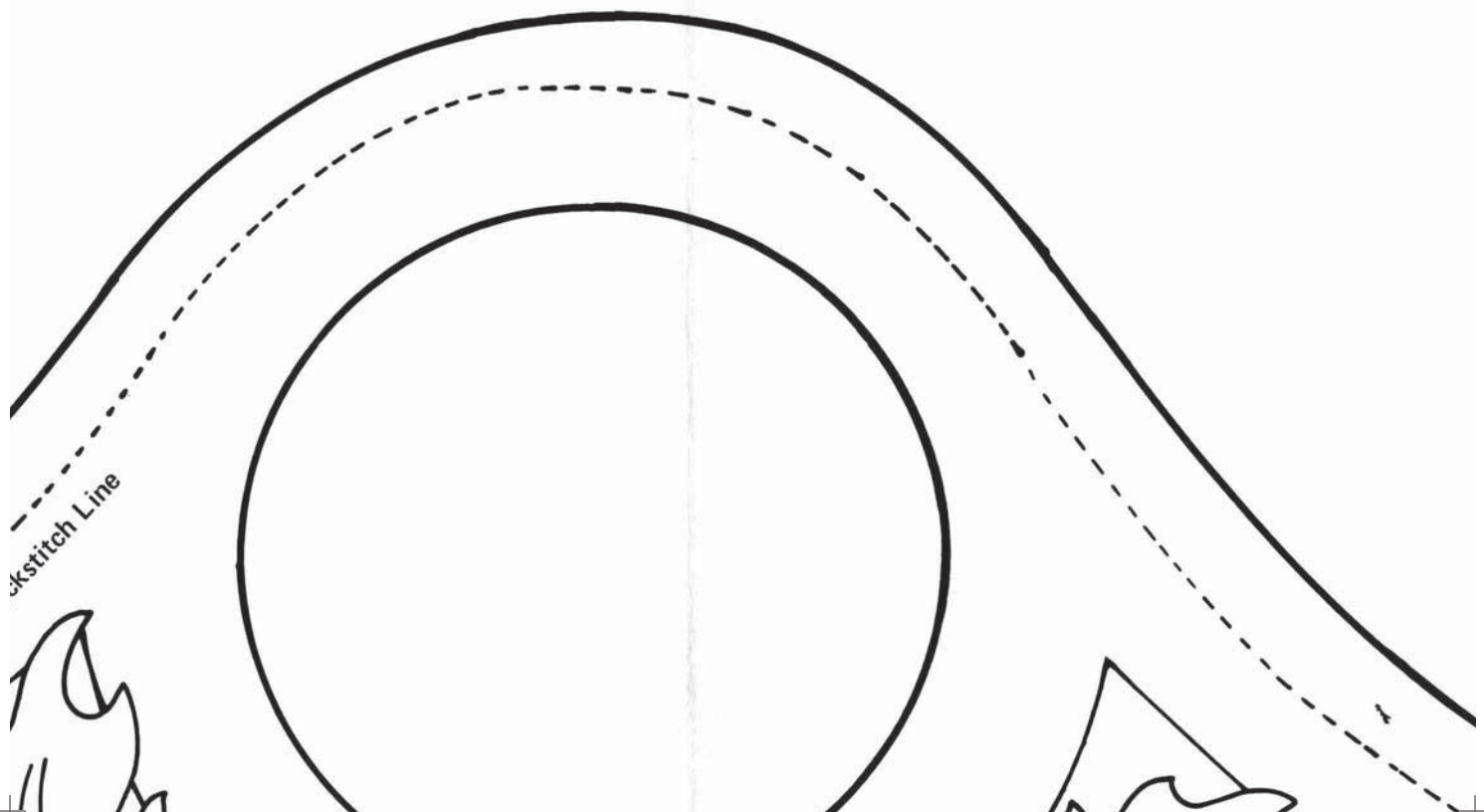

JKstitch Line

Pattern
by

Kathleen Bond









Buckstitch Line

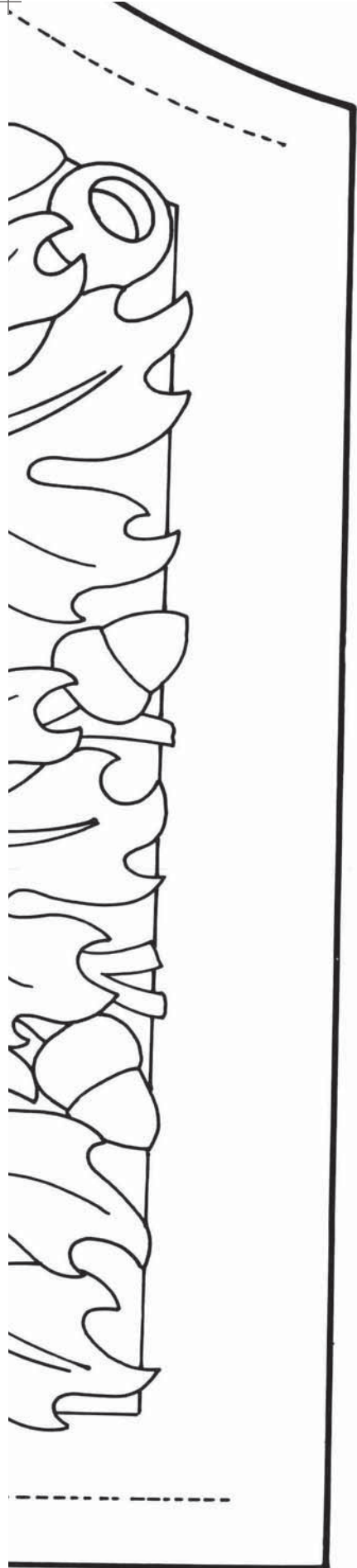

F902

B899

F896

B971

B701

A104

P213

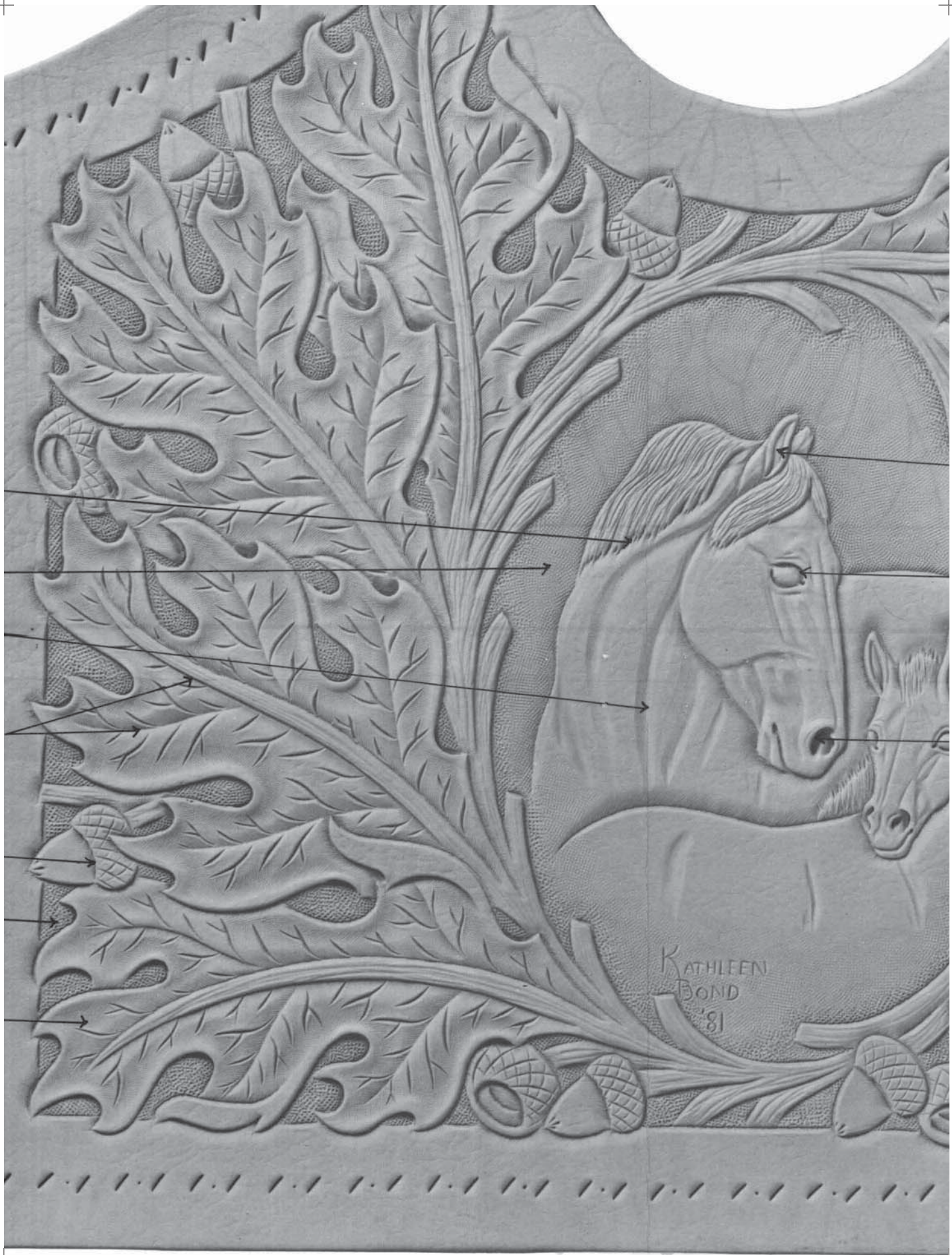

KATHLEEN
BOND
'81

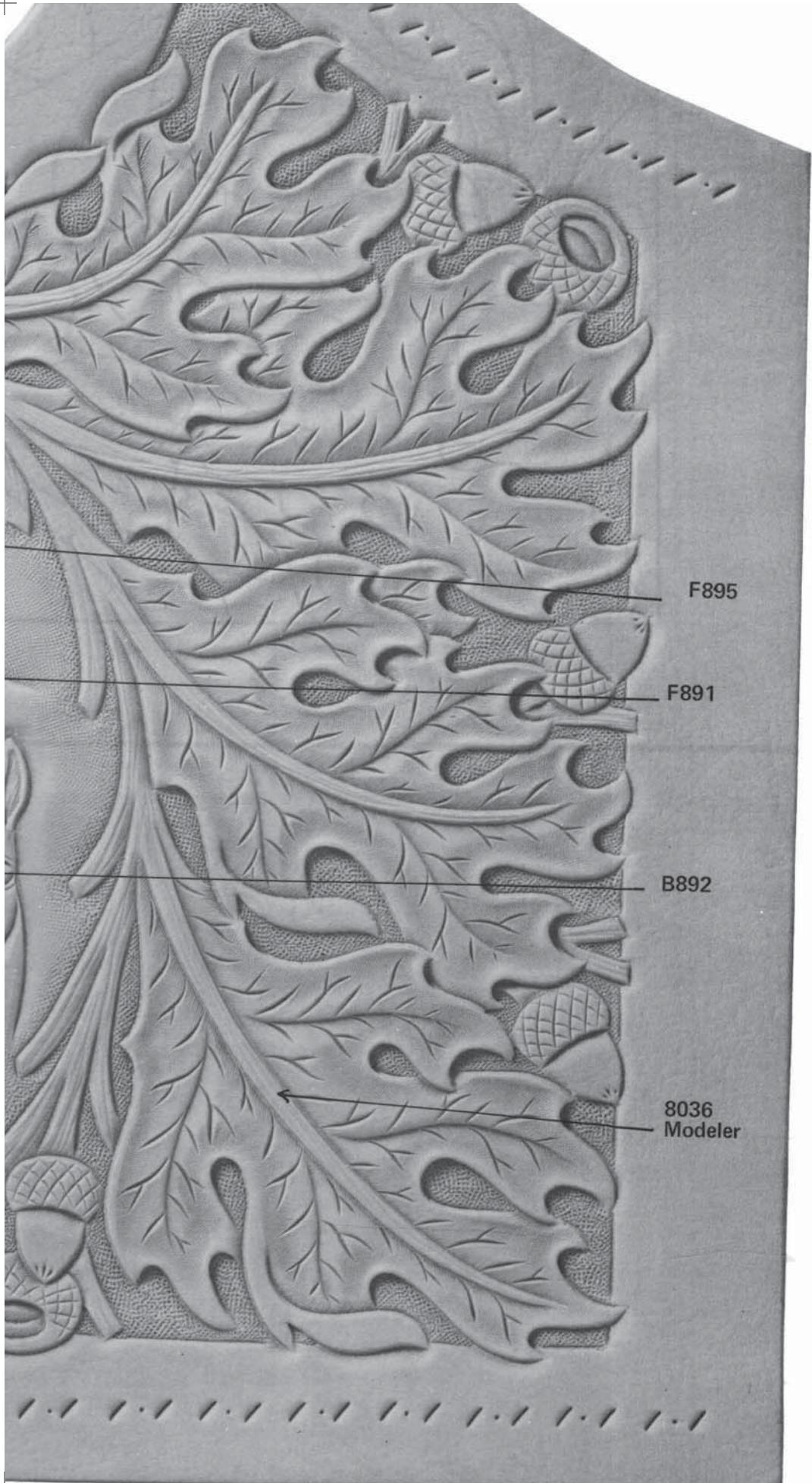

F895

F891

B892

8036
Modeler

MARKET PLACE HANDBAG KIT NO. 4381

**THIS AREA MAY BE USED FOR
ANY NUMBER OF SCENES OTHER
THAN THE HORSES SHOWN.
USE YOUR IMAGINATION!**

