

6...new...
beautiful
LEATHERCRAFT
PROJECTS
(ACTUAL SIZE PATTERNS)
by Baird

LARGE
UTILITY BOX



MEDIUM
UTILITY
BOX



SMALL
UTILITY
BOX



HORSE SHOE
BAG



WRITING
PORTFOLIO



COSMOPOLITAN
SHOULDER BAG



TOWN & COUNTRY PURSE



Pattern Digital Download

This PDF file contains 1 (one) full pattern package. The PDF has been put together to give you options when it comes to printing. Pages and patterns that are larger than 8½x11 have been provided in two formats:

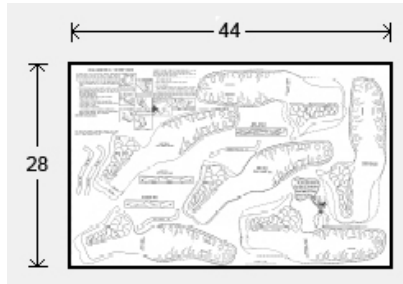

1) Full Size

If you would like to have a full size print out, take the full size pages to your local print shop and they can print it for you.

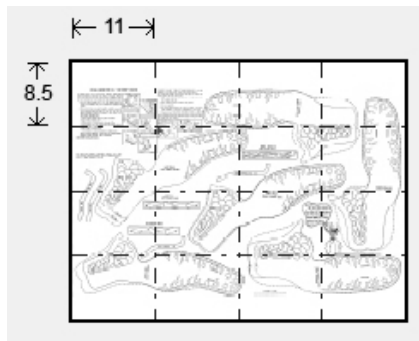

2) Tiled

The tiled pages give you the option of printing the larger patterns at home. You print the tiled pages and then assemble them to make the larger patterns.

The pattern PDF files are typically laid out like this:

Cover(if applicable), instructions sheets (if applicable), pattern 1 – full sized, pattern 1 – tiled, pattern 2 – full sized, pattern 2 – tiled, pattern 3 – full sized, pattern 3 – tiledetc

Please note: When printing on a home printer, the edges may get cut off. To avoid this, make sure “Page Scaling” is set to “Shrink to Printable Area” in the Adobe Reader print dialogue box. This will decrease the size of the pattern a very small amount.

NOTE: Digital kit patterns do not include any kit parts that they may reference.

NOTE: Some patterns may reference tools, and other items no longer available.

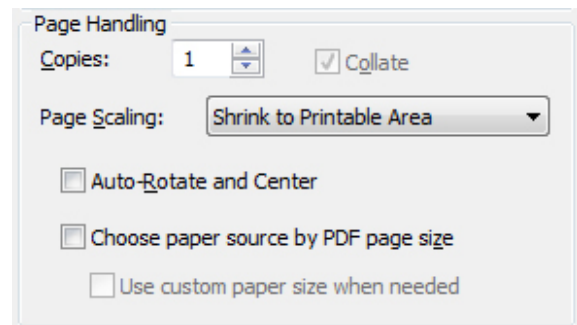

You may take this PDF file to your local print shop to have the full-size pages printed for your own personal use.

Horse Shoe Bag

Procedure

1. Make tracing and cutting patterns.
2. Cut project from leather. 4 or 5 oz. strap leather or tooling calf.
3. Moisten leather with sponge, allowing moisture to penetrate, then let surface dry until it has ALMOST turned to the original color.
4. Transfer tracing design to cased leather, using 4H drawing pencil or stylus.
5. Carve and stamp design, "see carving procedure".
6. Use woolskin pad to polish all grain sides of the project, polish each carving immediately after carving is finished.
7. Skive all outside edges that are to be faced.
8. Study and follow assembly instructions.

Suggestions for alternate construction, splice under handle, using any grain leather for body of purse, in contrast to the carved flap.

Suggestions for carving variations: carve and fillgore flap by removing background areas, and backing with gold vicid kid, or color choice.

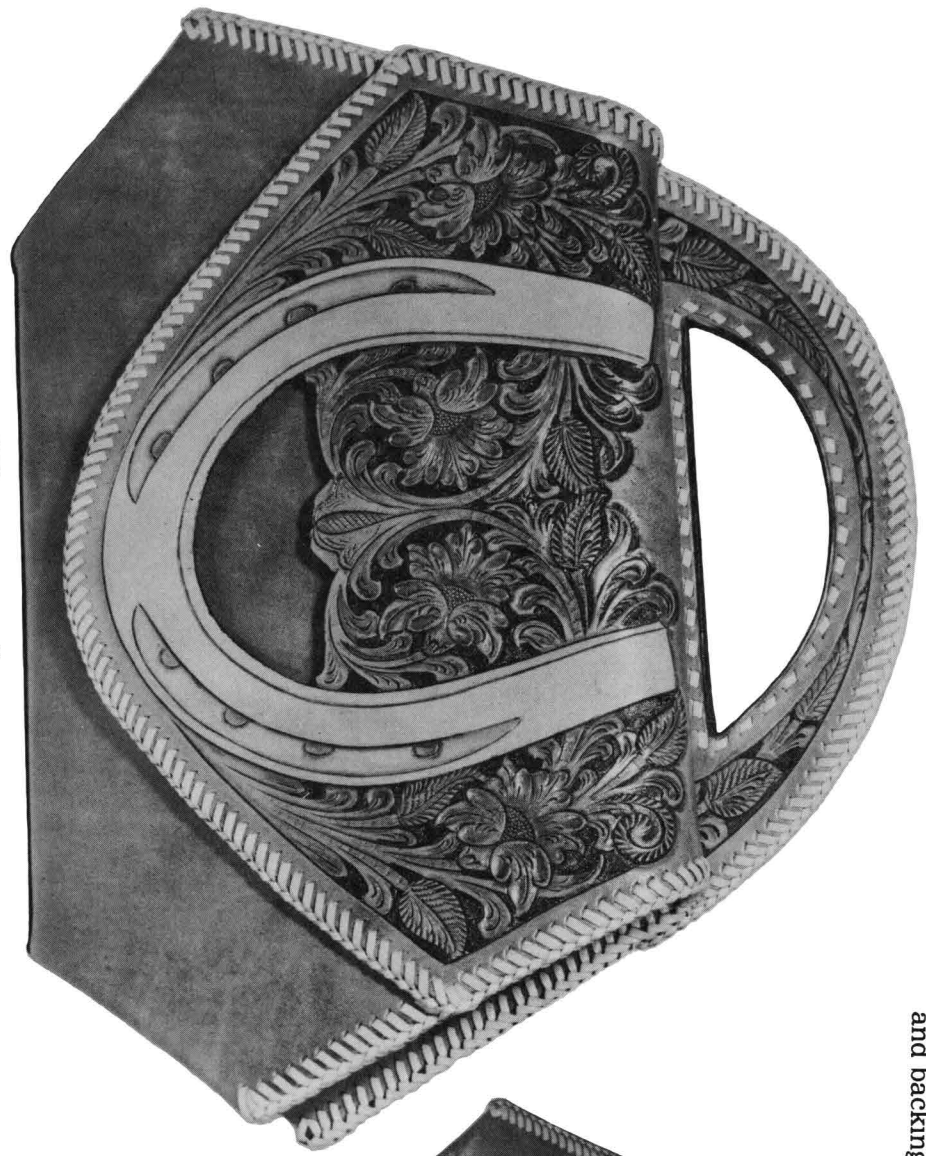

Completed Project

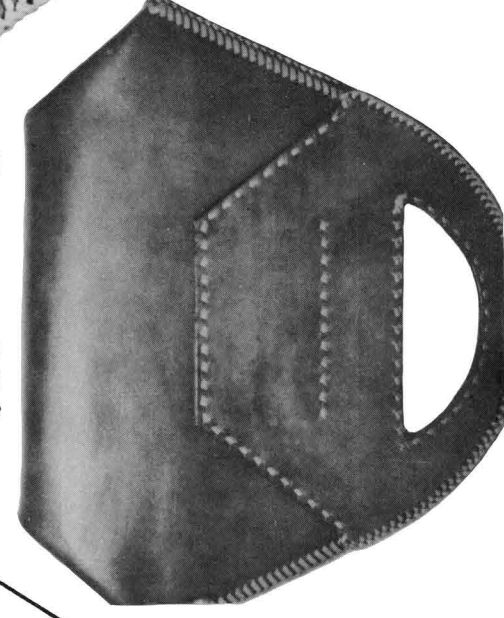

Back View

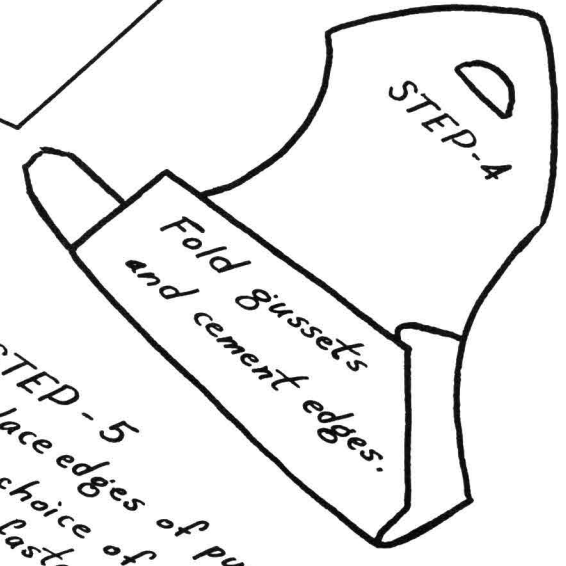
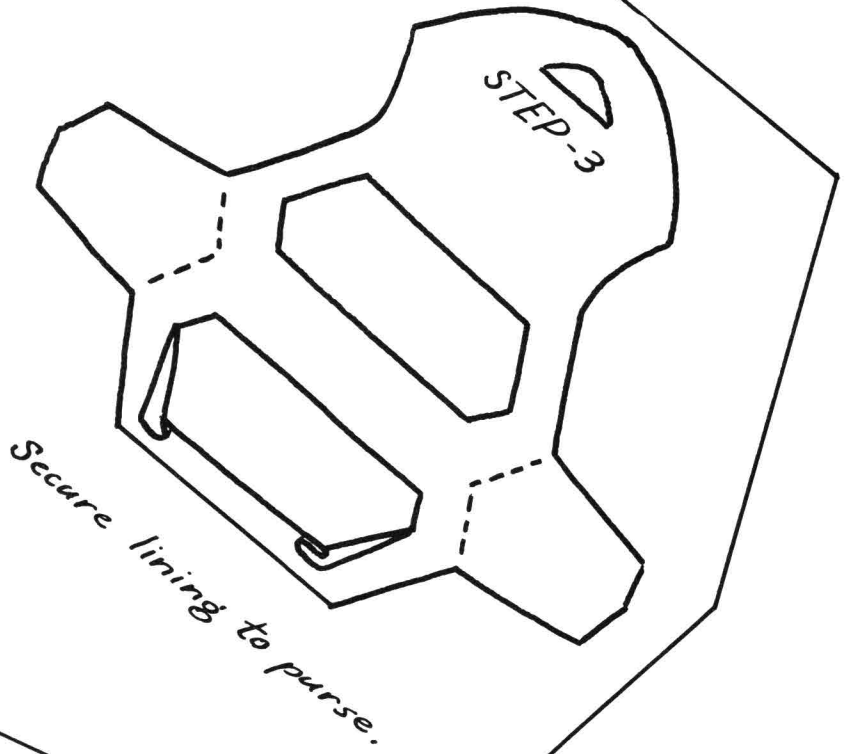
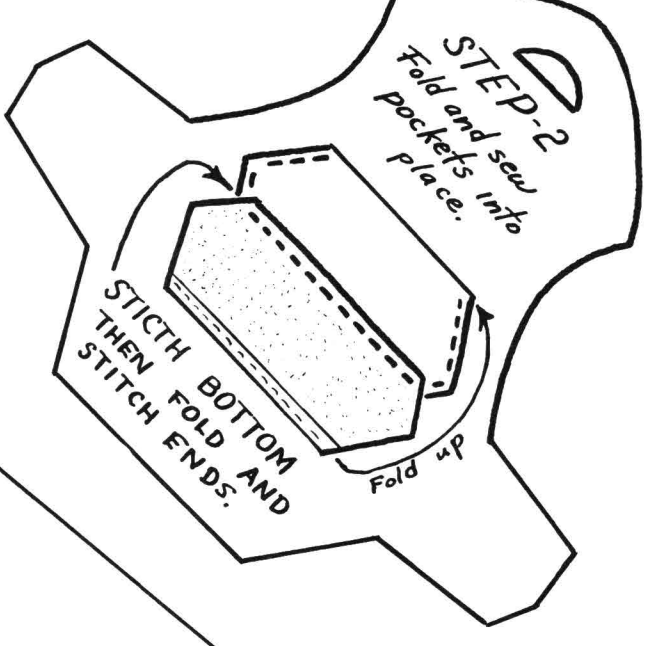
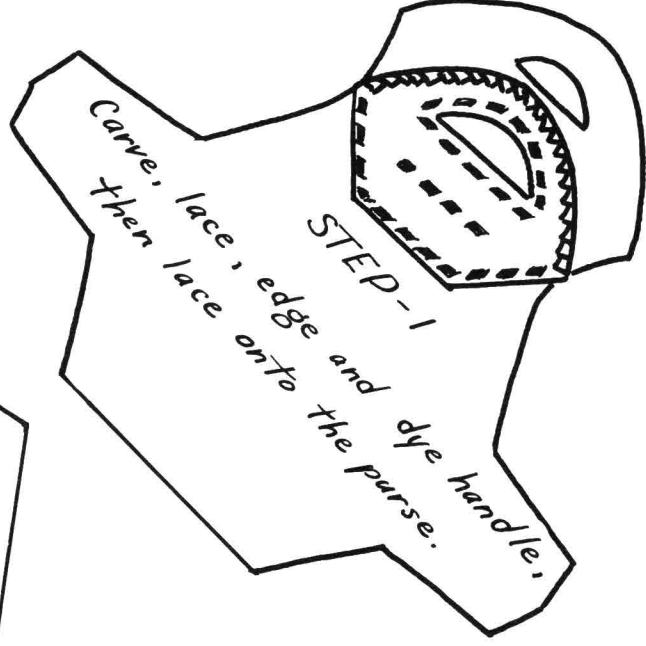
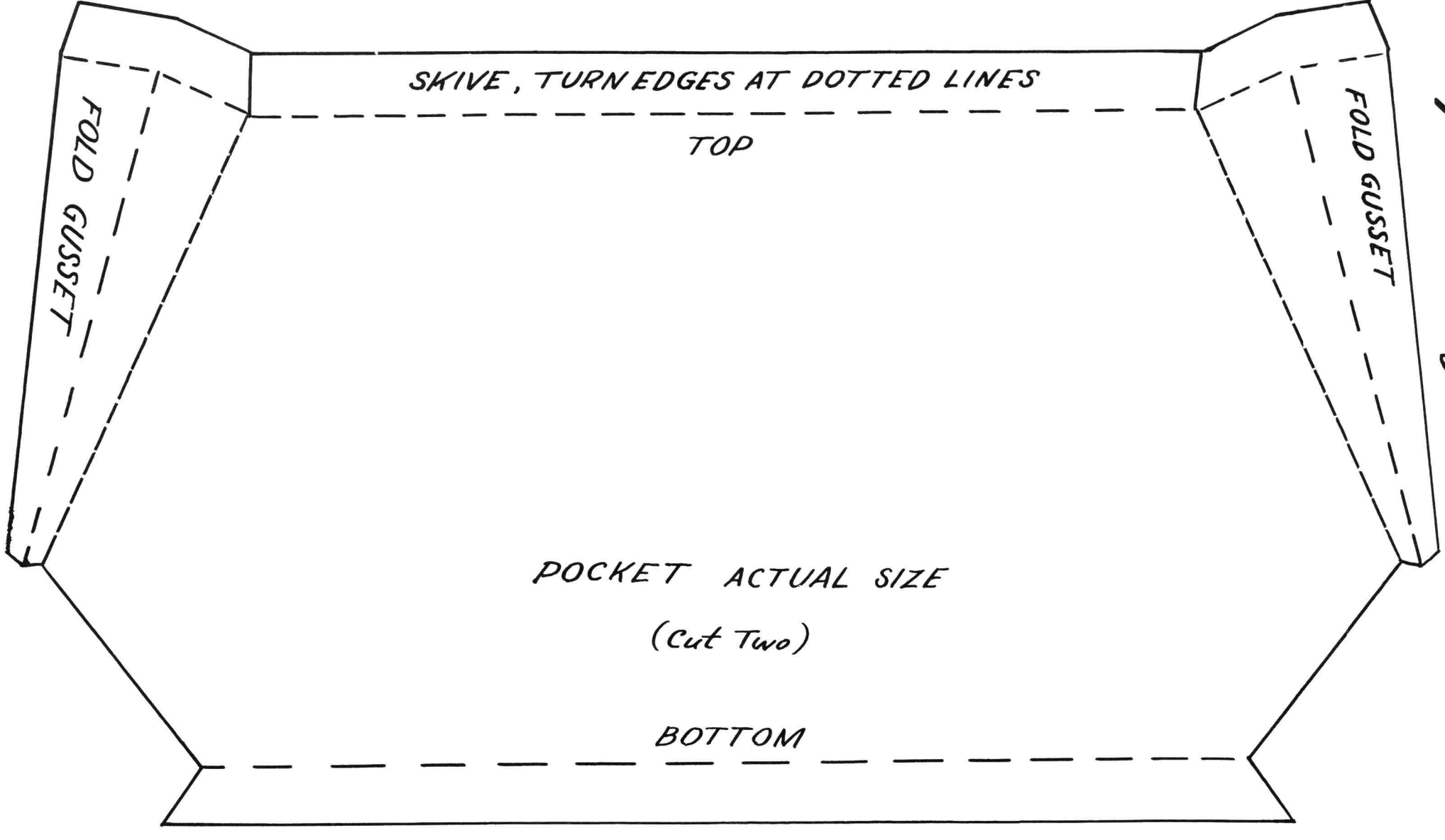

STEP-5 Punch and lace edges of purse. Use your choice of snap fastener.

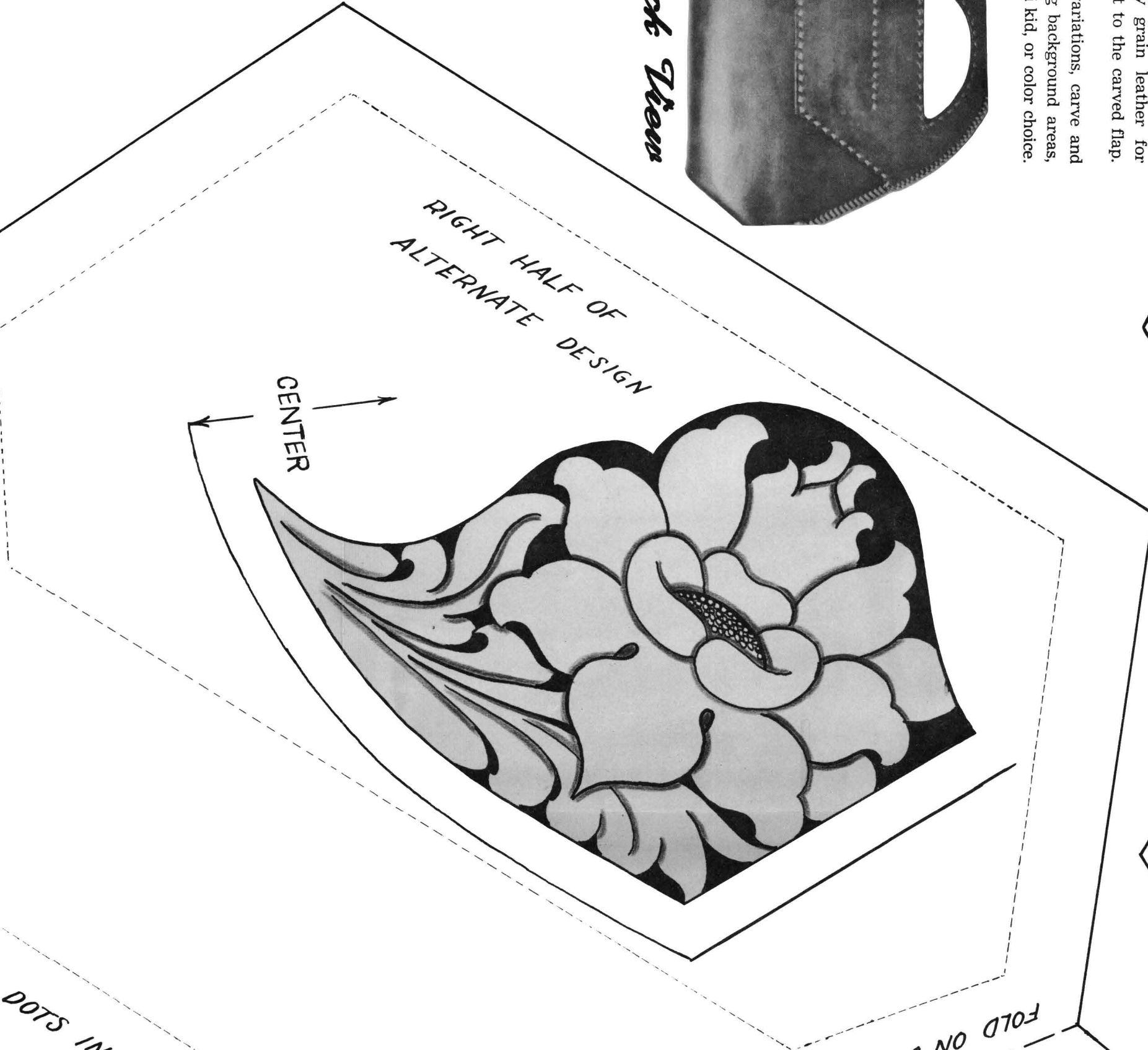
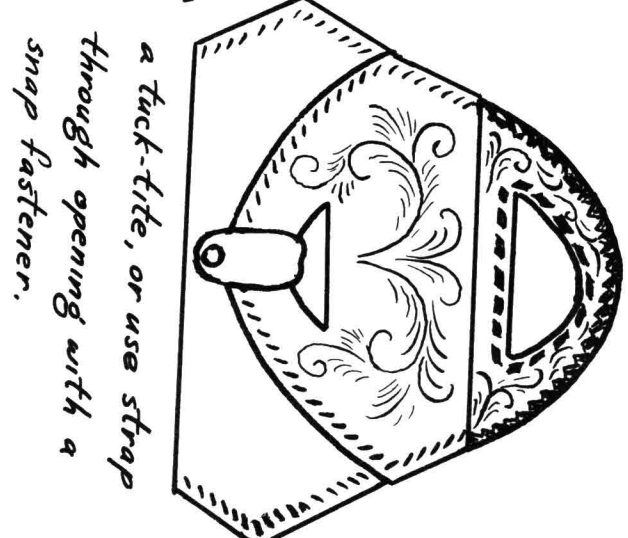

Carving Procedure

1. Skived cut border lines; then flowers, leaves, stems, in this order.
 2. Use large beveler, which will raise the border as a protection from the stamp.
 3. Pear-shading.
 4. Barkers' tool on leaves.
 5. Backgrounding.
 6. Beveling, first use large beveler on all main stems, in curves, next medium bevel.
 7. Camouflager on all main stems and flower petals.
 8. Veining.
 9. Use skived knife to ornamental cut design, study photo of the design.
 10. Stamp seed pod.
 11. Use large or medium beveler to reduced down all parts of the design rounded with the beveling tool.
- Always background with the SKIVED COMPASS to mark uniform border lines, before using skived cutter.

SMALL DOTS INDICATE POSITION OF POCKETS

PLACE BOTTOM OF HANDLE HERE

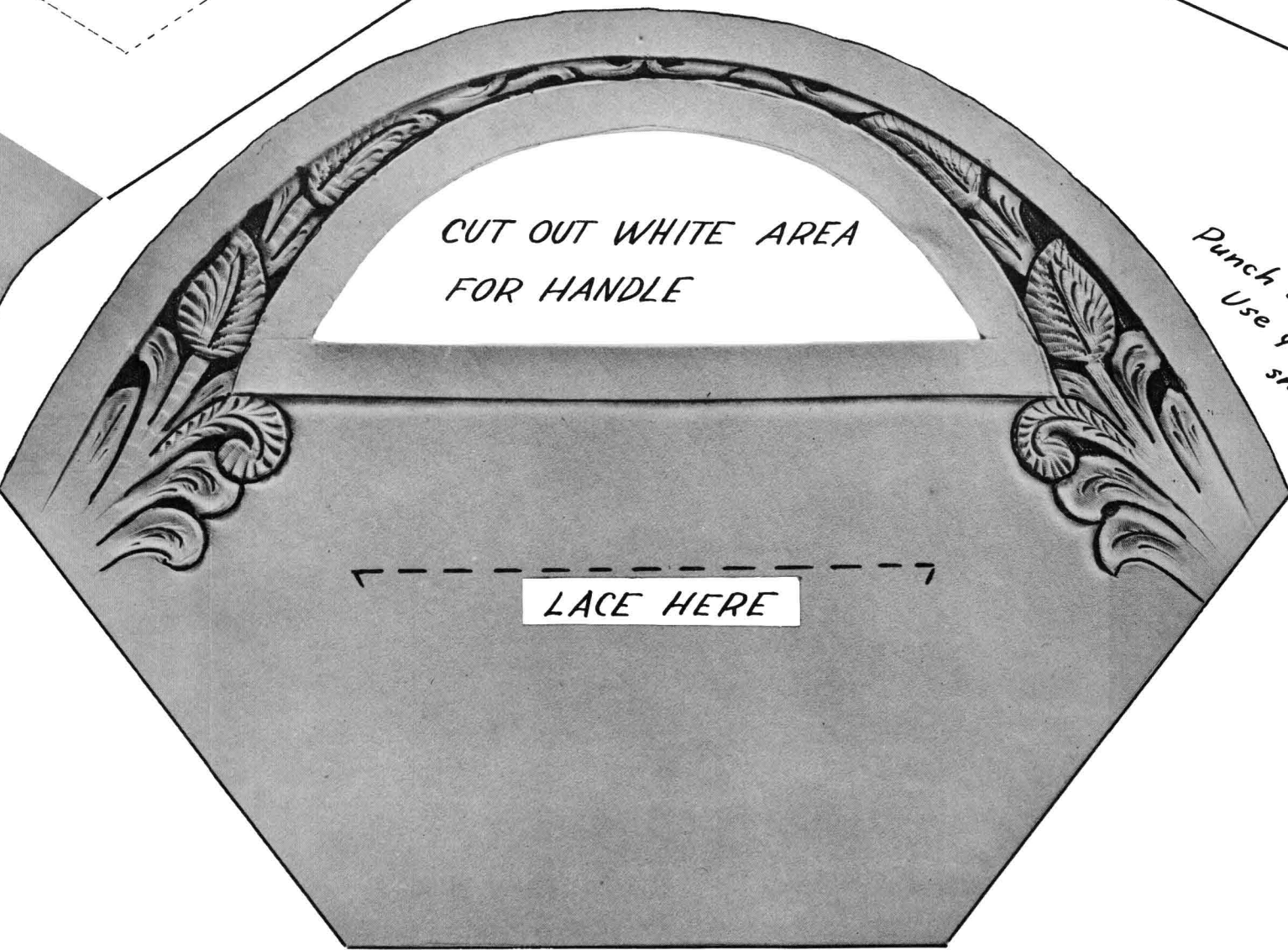

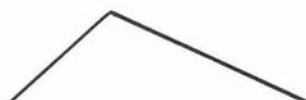
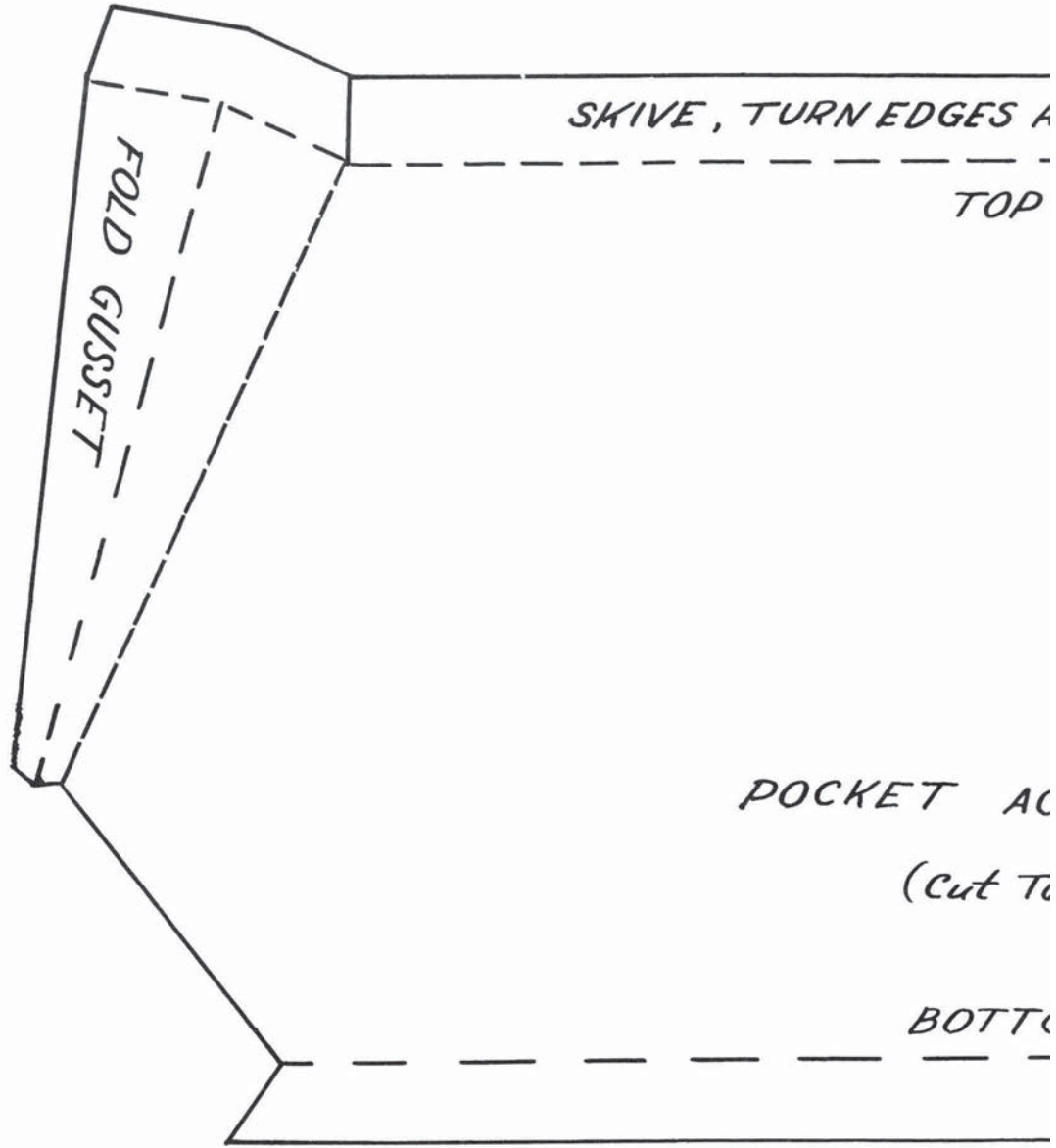

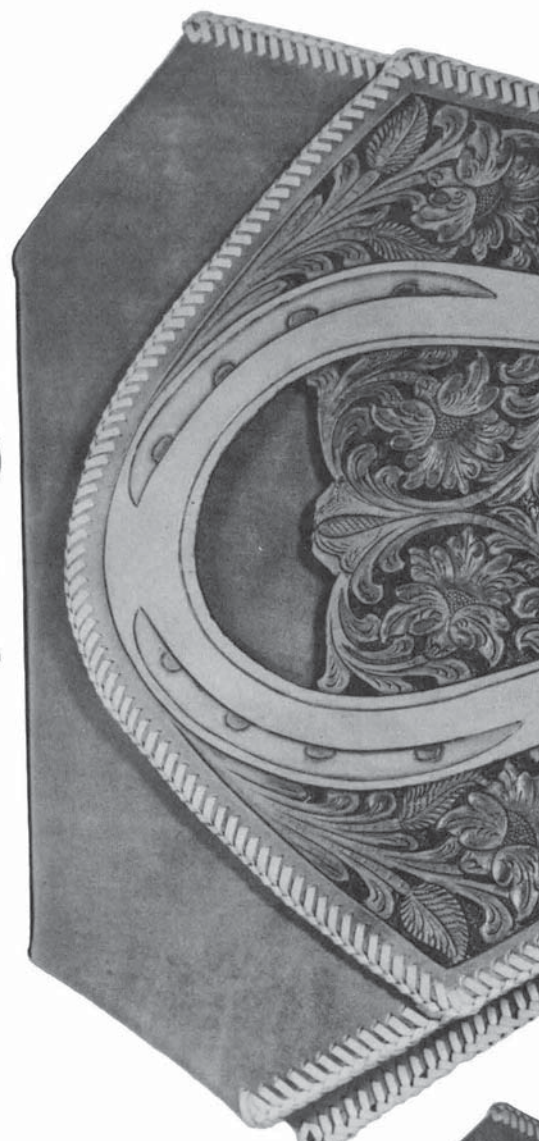

Back Tie

Completed Project

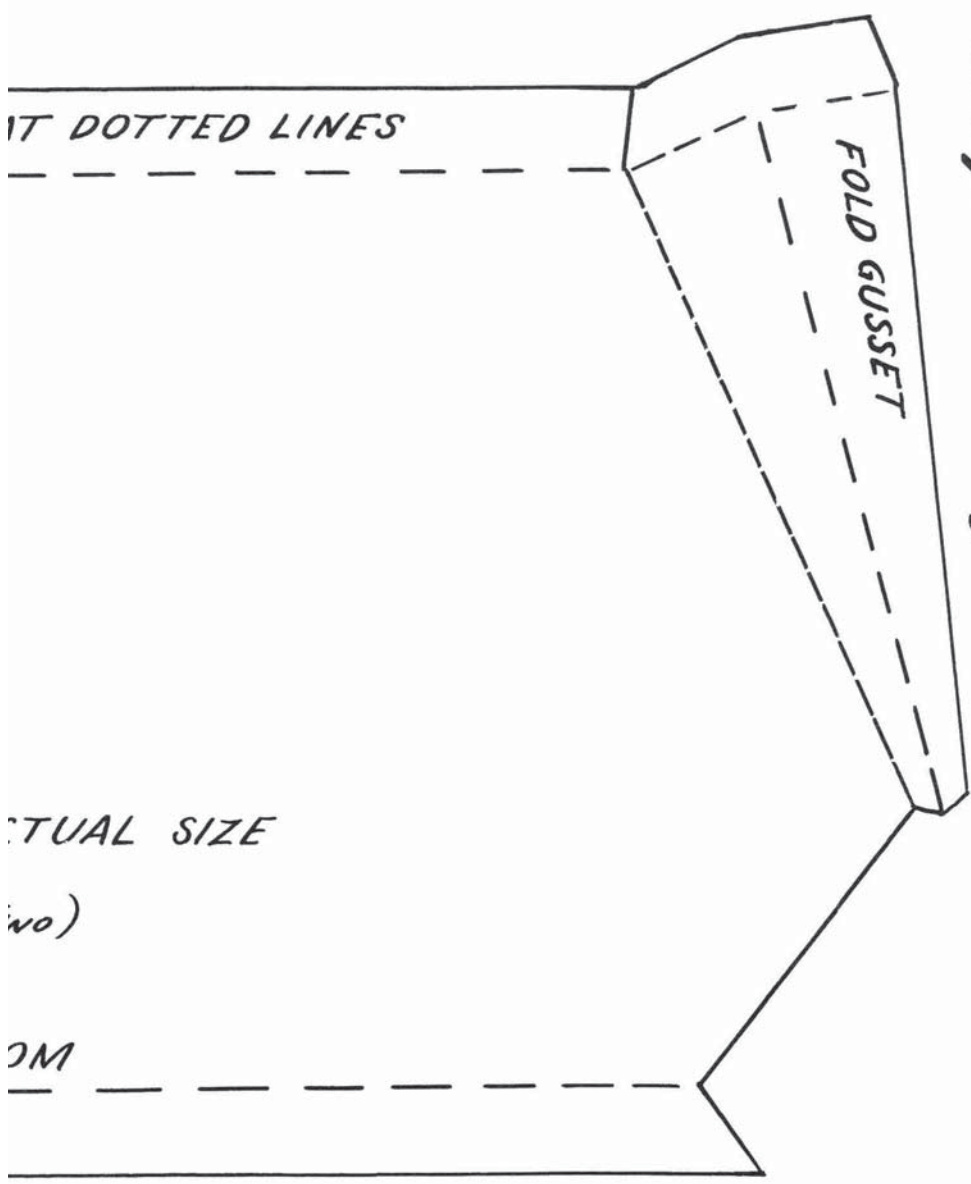

IT DOTTED LINES

FOLD GUSSET

ACTUAL SIZE

no)

CM



Horse Shoe Bag

Procedure

1. Make tracing and cutting patterns.
2. Cut project from leather, 4 or 5 oz. strap leather or tooling calf.
3. Moisten leather with sponge, allowing moisture to penetrate, then let surface dry until it has ALMOST turned to the original color.
4. Transfer tracing design to cased leather, using 4H drawing pencil or stylus.
5. Carve and stamp design, "see carving procedure".

6. Use woolskin pad to polish all grain side the project, polish each carving immediately after carving is finished.

7. Skive all outside edges that are to be lapped.
8. Study and follow assembly instructions.

Suggestions for alternate construction, shown under handle, using any grain leather under body of purse, in contrast to the carved

Suggestions for carving variations, carve filigree flap by removing background and backing with gold vici kid, or color change



Swiveling Procedure

1. Swivel cut border lines, in this order.
2. Use large beveler to bevel border lines, bevel to INSIDE, which will raise the border as a protection from the stamp tools.
3. Pear-shading, then flowers, leaves, stems, in
4. Barker tool on leaves.
5. Backgrounding.
6. Beveling, first medium beveler, then large beveler.
7. Camouflager on all main stems and flower petals.
8. Veining.
9. Use swivel knife to ornamental cut design, study photo.
10. Stamp seed pod.
11. Use large or medium beveler to re-bevel down all parts of the design touching the border, being careful not to touch background with the beveling tool. Always use SADDLERS compass to mark uniform border lines, before using swivel cutter.

RIGHT HALF OF
ALTERNATE DESIGN

CENTER

FOLD ON DOTTED LINES

Can

SMALL DOTS INDICATE POSITION OF POCKETS

PLACE BOTTOM OF HANDLE HERE

LINES

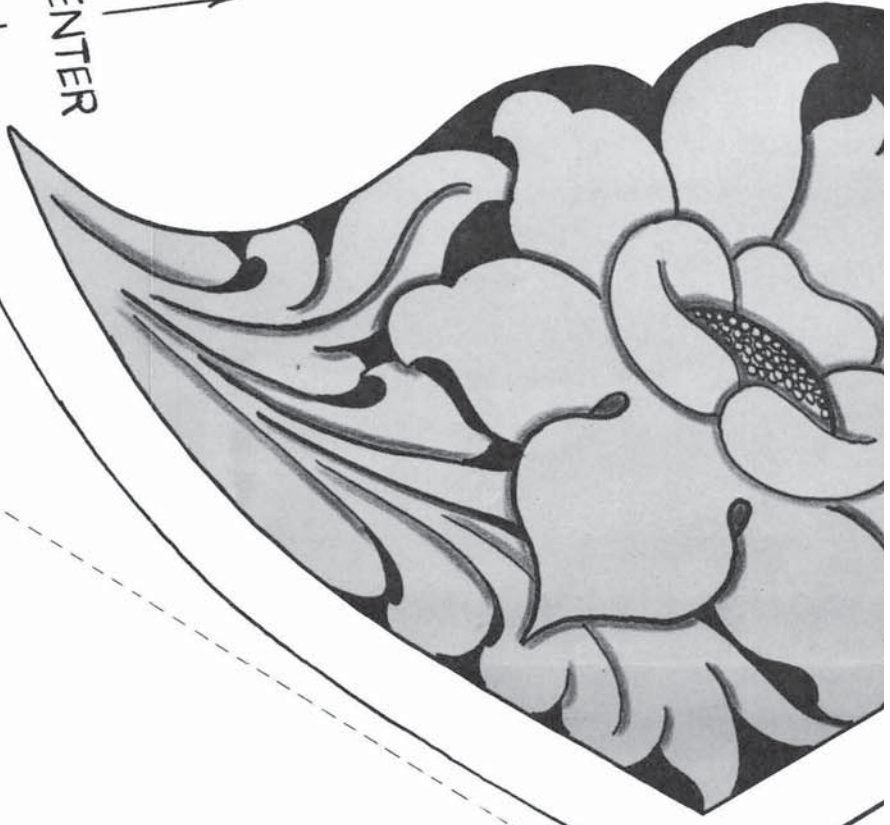

as of
ately
aced.
piece
for
flap.
and
reas,
oice.

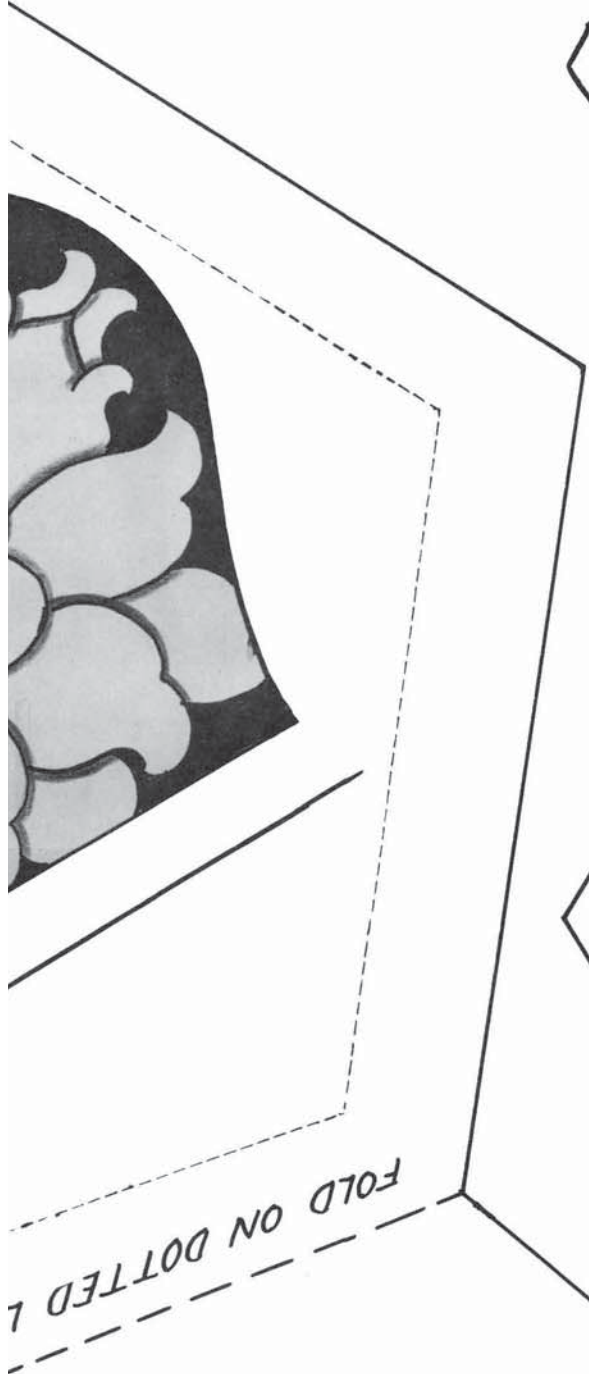
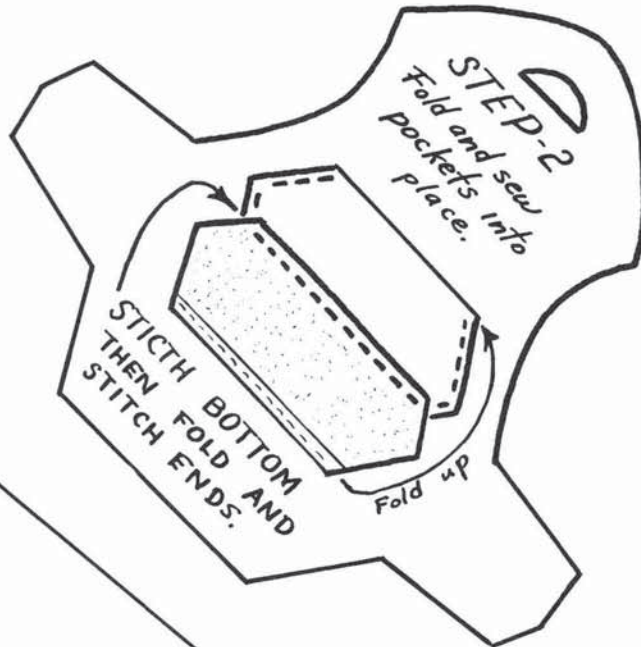
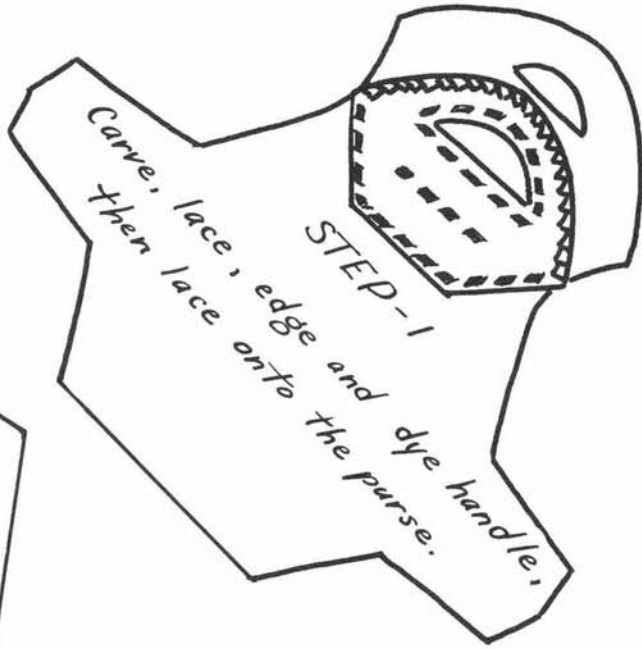



CUT OUT THIS AREA
IF DESIRED

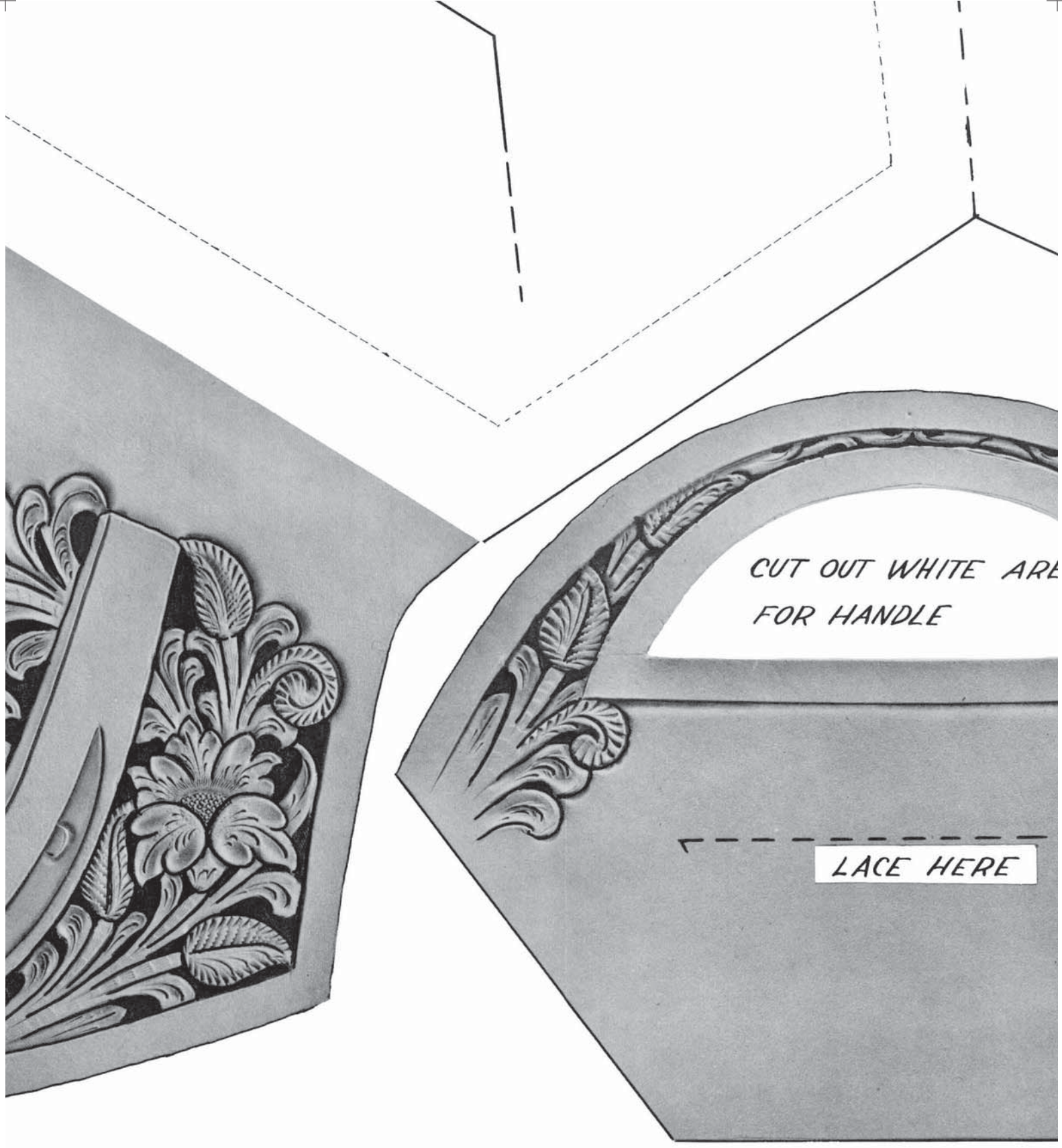

CUT OUT WHITE AREA
FOR HANDLE

LACE HERE

Secure lining to purse.

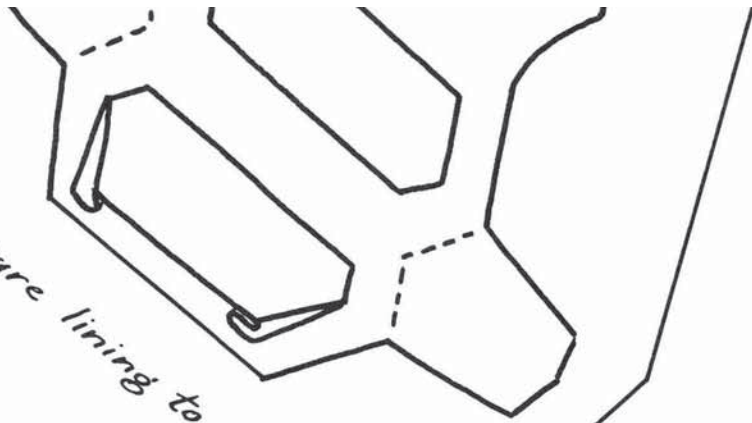

STEP-4

Fold gussets and cement edges.

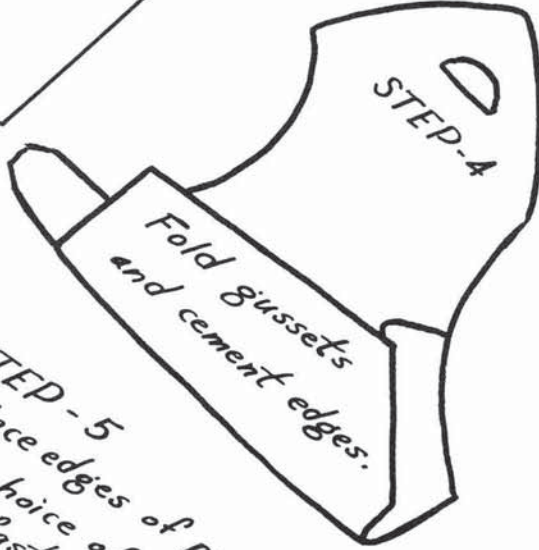

STEP-5
*Punch and lace edges of purse.
Use your choice of snap fastener.*

a tuck-tite, or use strap through opening with a snap fastener.

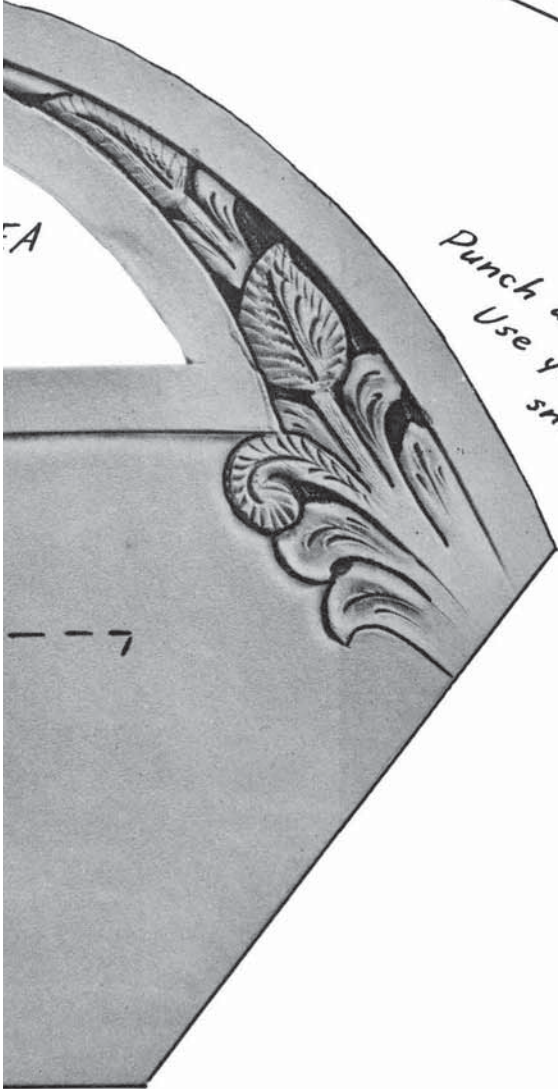
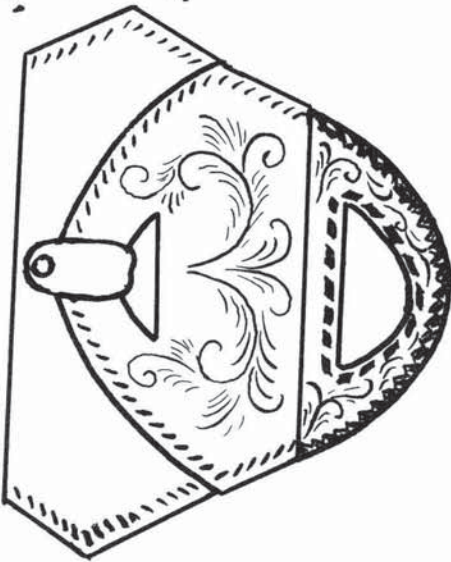

FA

Esomopolitan

PROCEDURE

1. Make tracing and cutting patterns.
2. Cut project from leather, 3-4 oz. strap, veal, or tooling calf as sample.
3. Moisten leather with sponge, allowing moisture to penetrate, then let surface dry until it has ALMOST turned to the original color.
4. Transfer tracing design to cased leather, using 4H drawing pencil or stylus.
5. Carve and trace design, (see carving procedure).
6. Use woolskin pad to polish all grain sides of the project IMMEDIATELY after each piece of carving is finished.
7. Skive all outside edges that are to be laced.

CARVING PROCEDURE

1. Swivel cut flowers, butterflies, stems in this order.
2. Pear-shading
3. Backgrounding.
4. Beveling, first use large beveler on all long straight cuts, next use medium beveler.
5. Pull camouflager over all main stems.
6. Use veiner on the acanthus inside the large flower.
7. Use swivel knife to ornamental cut, (study photograph).
8. Use wool skin pad to polish each carving IMMEDIATELY after the carving is completed.
9. Use choice of finish, this purse was made from tooling calf, with the background dyed, butterflies varnished, then antique over the entire purse, the varnish will keep the butterflies a light shade in contrast to the other parts of the purse.

ASSEMBLY INSTRUCTIONS

STEP-1

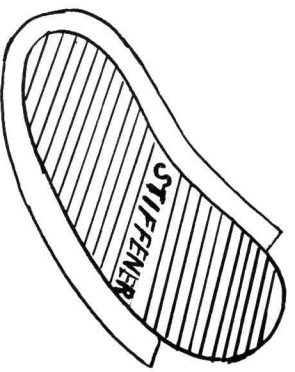

STEP-2

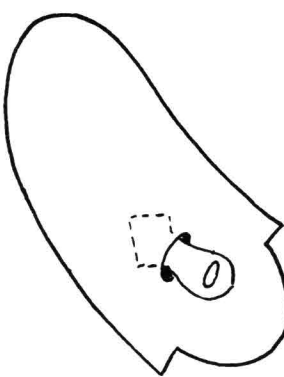

1. Punch $\frac{3}{8}$ " hole through outer gusset and stiffener, using BAG PUNCH.
2. Line TAB, edge, crease and dye edges of tab, then punch $\frac{3}{8}$ " hole in tab for shoulder strap, which will be applied later.
3. Skive button end of tabs then insert through hole and cement to underside of stiffener, (as indicated above).

STEP-3

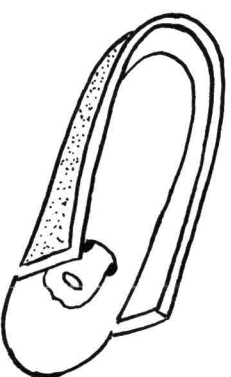

1. Moisten edges of gusset then use wide faced hammer to form gussets, (as shown above). Forming edges of the gusset is very important to the future shape of the finished purse, also will allow easier lacing.

STEP-4

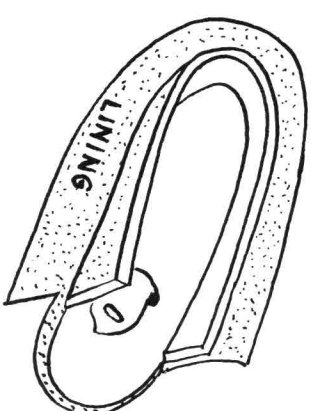

1. Line gussets, first cement flat surface, then cement turned-up edges, which will aid in retaining the desired shape.

STEP-5

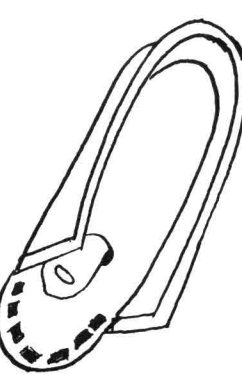

1. At this point, choose style of lacing desired. This purse uses the narrow DUNCAN DIAGONAL slit punch, then laced with $3/32$ " natural goat lacing.
2. Lace top of gussets, (indicated above), after lacing, hammer the lace flat with a wide faced hammer.

STEP-6

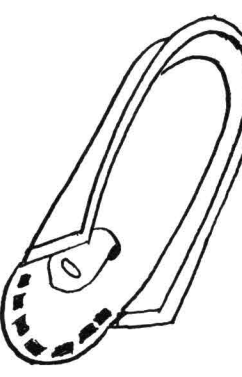

1. Make pockets and secure to lining, then cement lining to body of purse.
2. Lace across front of the purse as (indicated above).

STEP-7

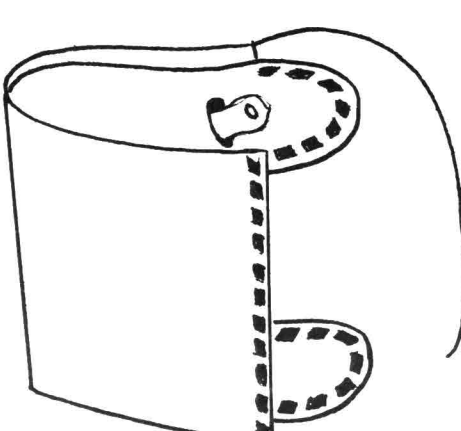

1. Cement gussets into position, (indicated above).
2. Punch and lace all outside edges. If a diamond lace is used, place a block of wood under outer edges as a punching base, for the round bottom gussets, use $\frac{3}{4}$ " or 1" round stick secured in a vice.
3. Attach lock, PRESTO LOCK No. 888 was used on this purse.
4. Attach shoulder strap.

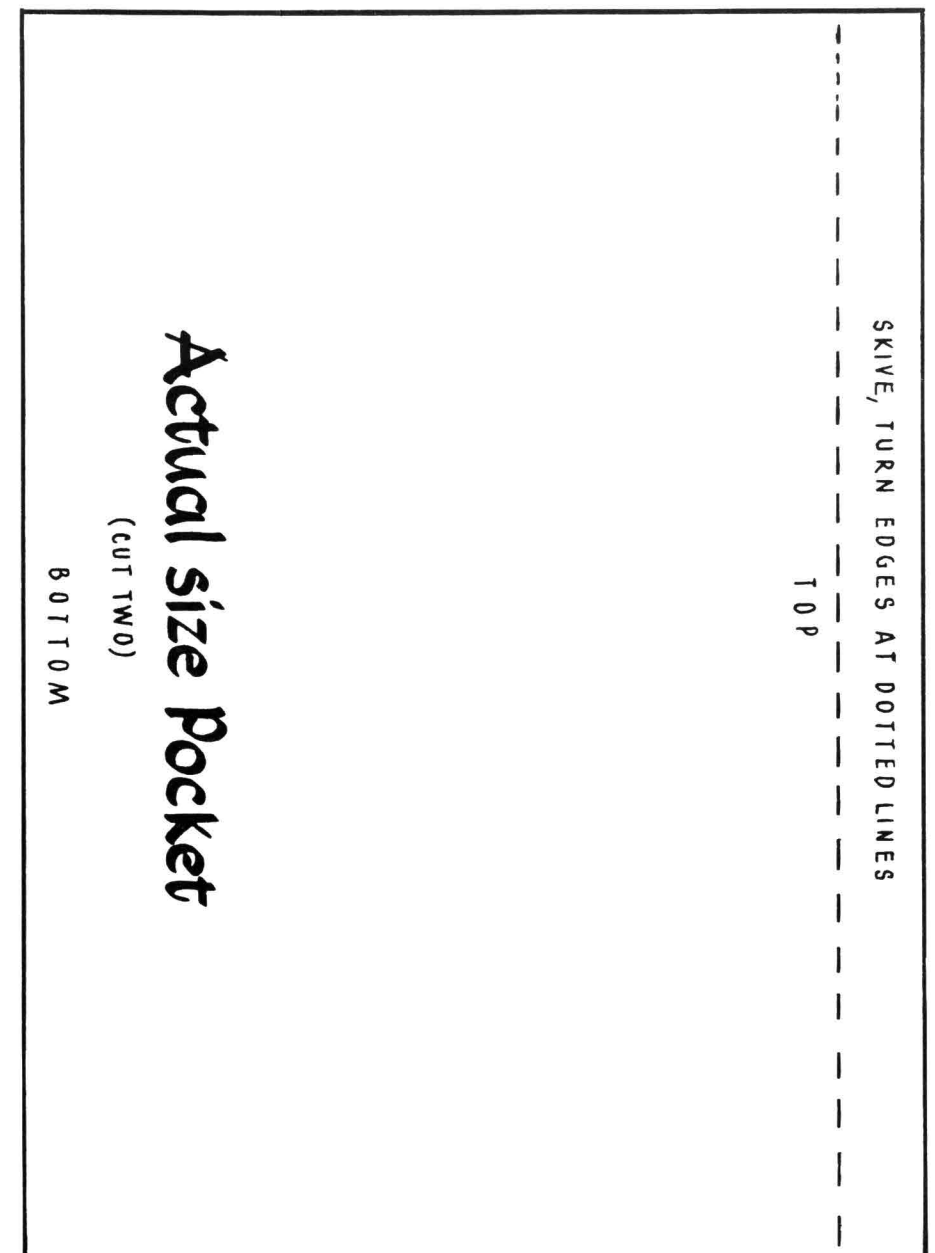

Completed Project

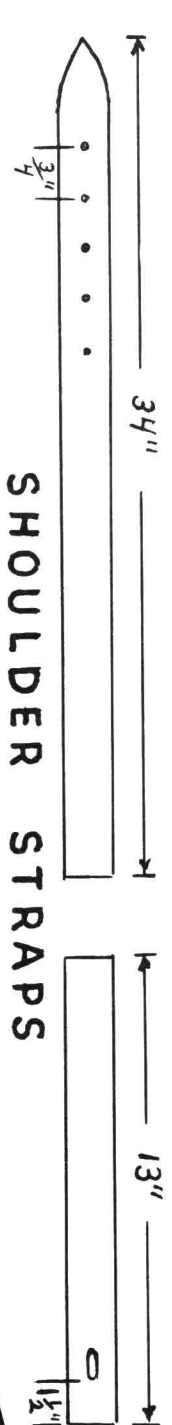

SHOULDER STRAPS

Bain Purse Pattern

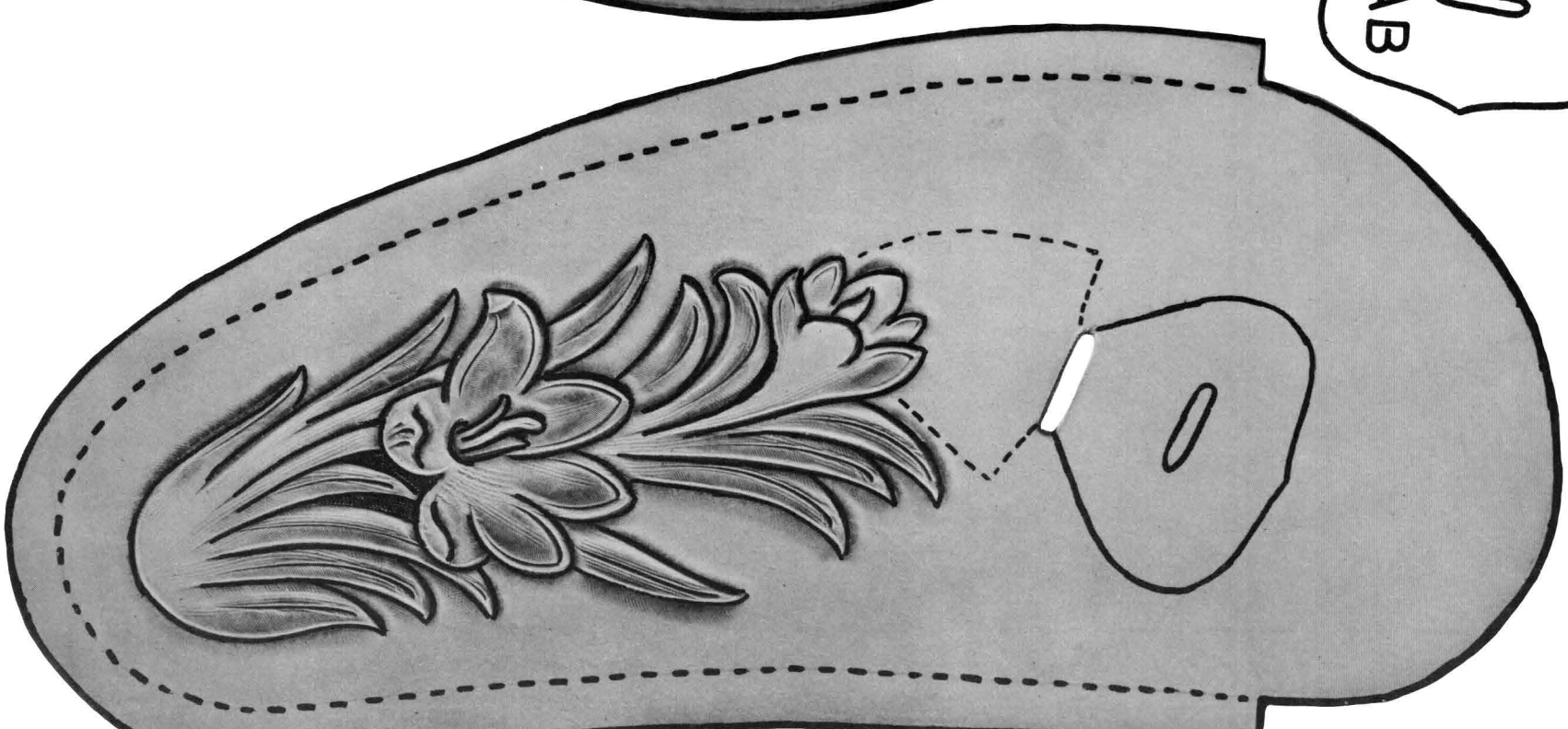
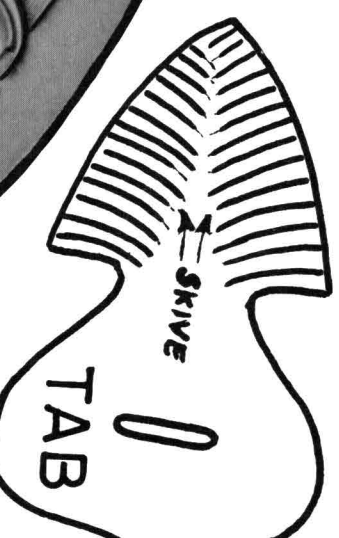
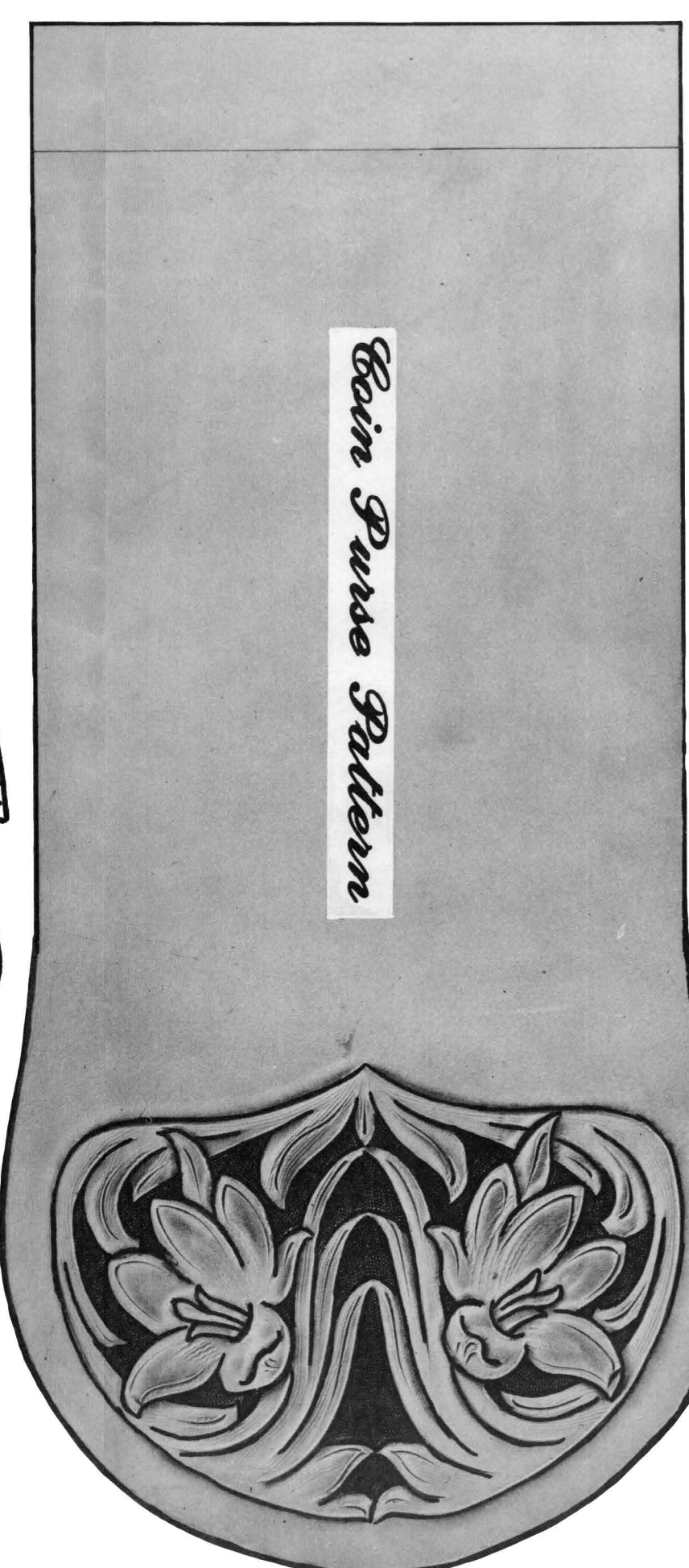

Place TOP of front pocket in position on the lining, (as indicated by DOTS), on actual size photo above.

Place BOTTOM of back pocket in position on the lining, (as indicated by DOTS), on actual size photo above.



Place TOP of front pocket in position on the lining, (as indicated by DOTS), on actual size photo above.

this order.

2. Pear-shading
3. Backgrounding.
4. Beveling, first use large beveler on all long straight cuts, next use medium beveler.
5. Pull camouflager over all main stems.
6. Use veiner on the acanthus inside the large flower.
7. Use swivel knife to ornamental cut, (study photograph).
8. Use wool skin pad to polish each carving IMMEDIATELY after the carving is completed.
9. Use choice of finish, this purse was made from tooling calf, with the background dyed, butterflies varnished, then antique over the entire purse, the varnish will keep the butterflies a light shade in contrast to the other parts of the purse.

SKIVE, TURN EDGES AT DOTTED LINES

TOP

Actual size Pocket

(CUT TWO)

BOTTOM



Cosmopolitan

PROCEDURE

1. Make tracing and cutting patterns.
2. Cut project from leather, 3-4 oz. strap, veal, or tooling calf as sample.
3. Moisten leather with sponge, allowing moisture to penetrate, then let surface dry until it has ALMOST turned to the original color.
4. Transfer tracing design to cased leather, using 4-H drawing pencil or stylus.
5. Carve and trace design, (see carving procedure).
6. Use woolskin pad to polish all grain sides of the project IMMEDIATELY after each piece of carving is finished.
7. Skive all outside edges that are to be laced.

ASSEMBL STEP-1

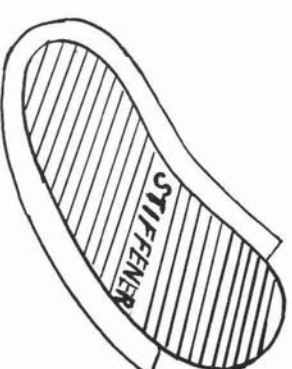

1. Punch $\frac{3}{4}$ " hole through outside edge.
2. Line TAB, edge, crease and tab for shoulder strap, which will be laced.
3. Skive button end of tabs 1/4" from edge of stiffener, (as in procedure).

CARVING PROCEDURE

1. Swivel cut flowers, butterflies, stems in

Place **BOTTOM** of back pocket in position on the lining, (as indicated by **DOTS**), on actual size photo above.

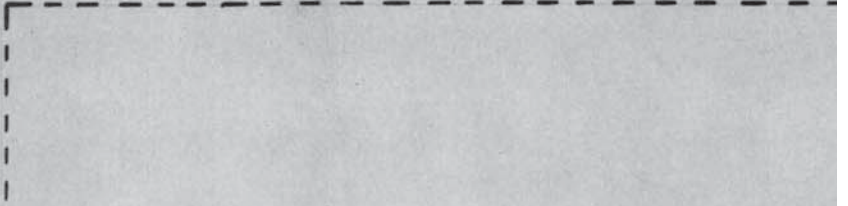

Completed Project

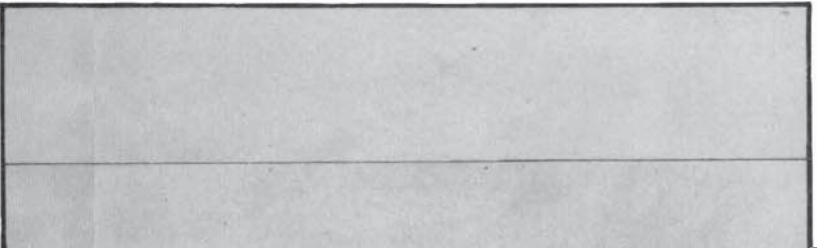
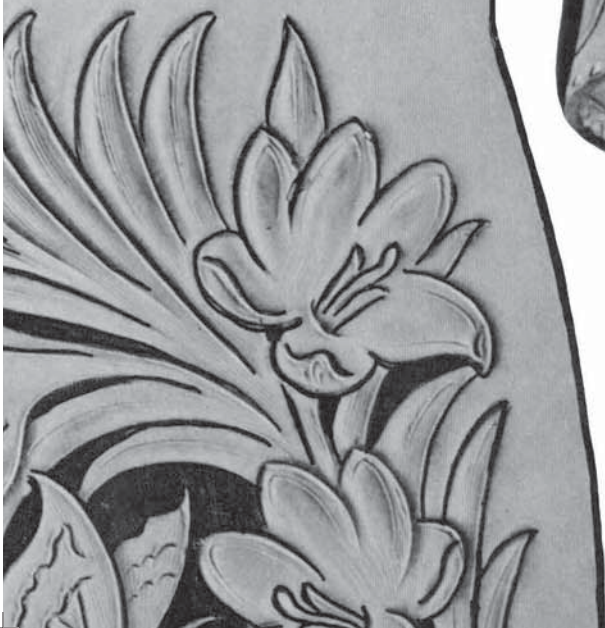

Y INSTRUCTIONS

STEP-2

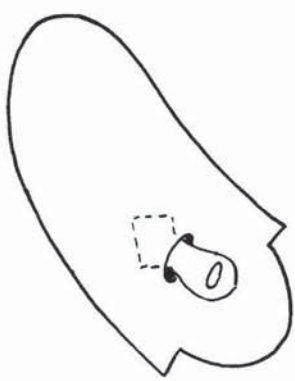

your gusset and stiffener, using BAG PUNCH. dye edges of tab, then punch $\frac{3}{8}$ " hole in which will be applied later. then insert through hole and cement to (indicated above).

STEP-3

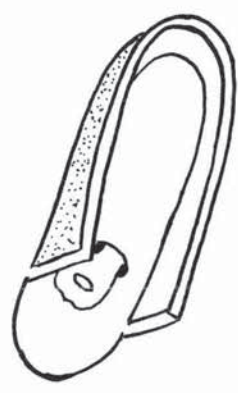

1. Moisten edges of gusset then use wide faced hammer to form gussets, (as shown above). Forming edges of the gusset is very important to the future shape of the finished purse, also will allow easier lacing.

STEP-4

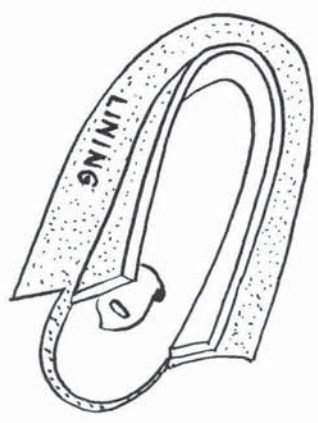

1. Line gussets, first cement flat surface, then cement turned-up edges, which will aid in retaining the desired shape.

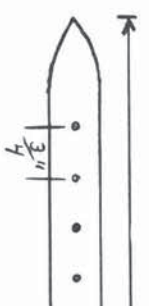

2.

1.

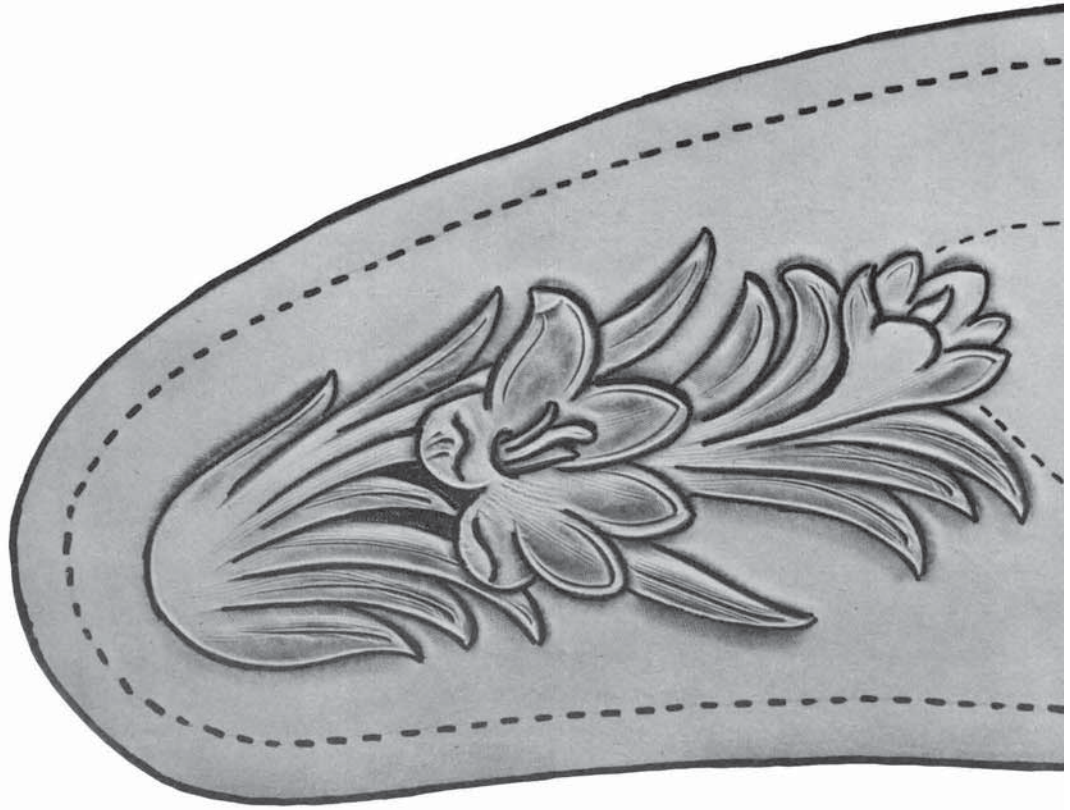

Bain Purse Pattern

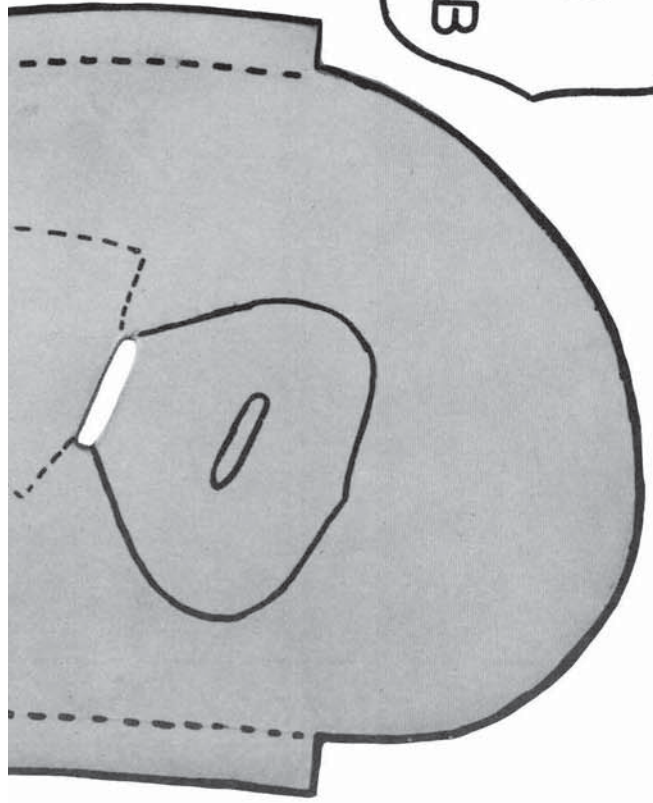
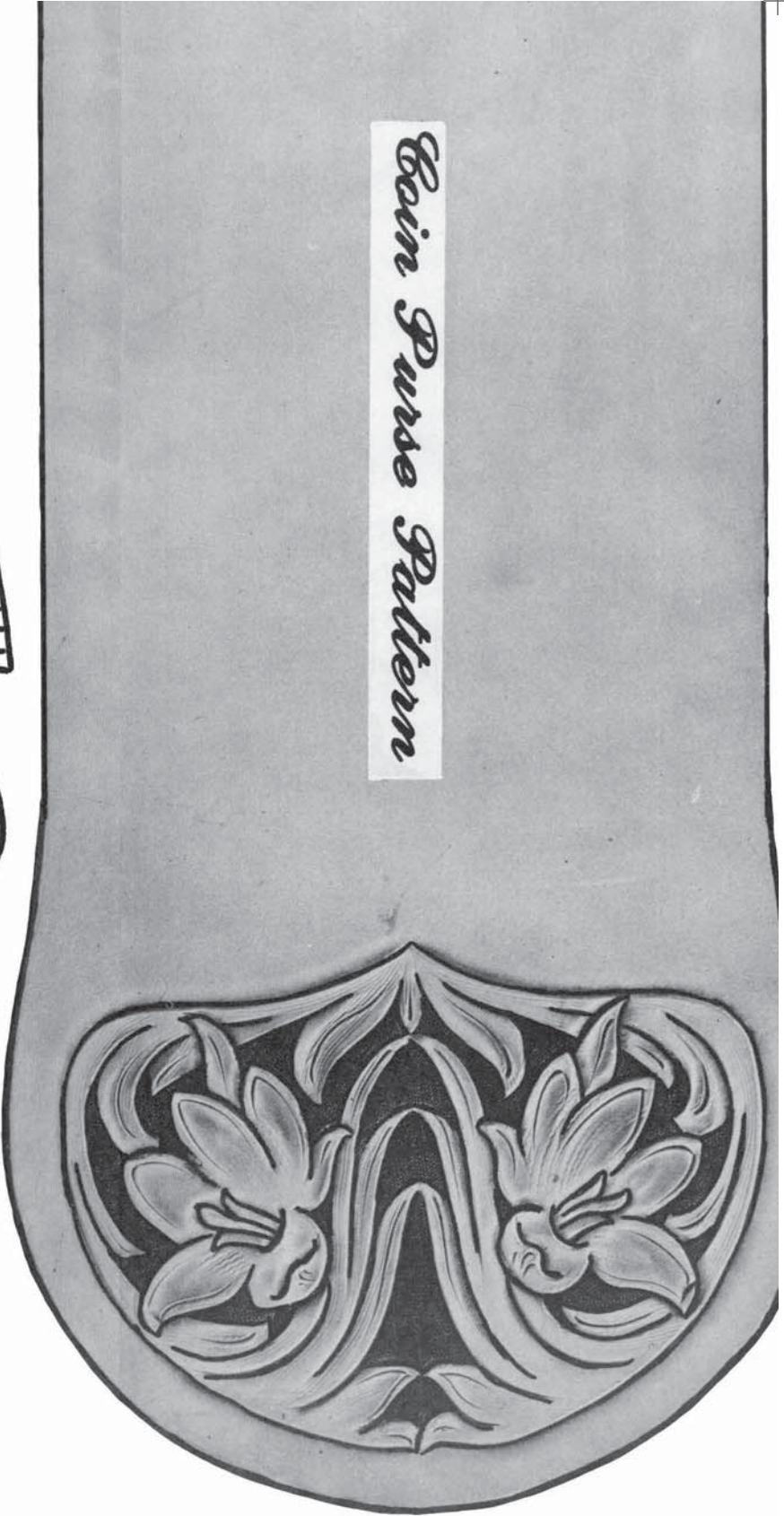

STEP-5

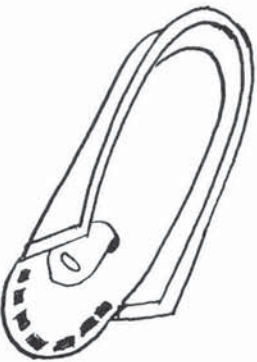

At this point, choose style of lacing desired. This purse was diamond laced and punched with the narrow DUNCAN DIAGONAL slit punch, then laced with $\frac{3}{32}$ " natural goat lacing.

Lace top of gussets, (indicated above), after lacing, hammer the lace flat with a wide faced hammer.

STEP-6

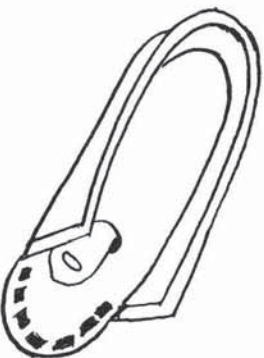

1. Make pockets and secure to lining, then cement lining to body of purse.
2. Lace across front of the purse as (indicated above).

STEP-7

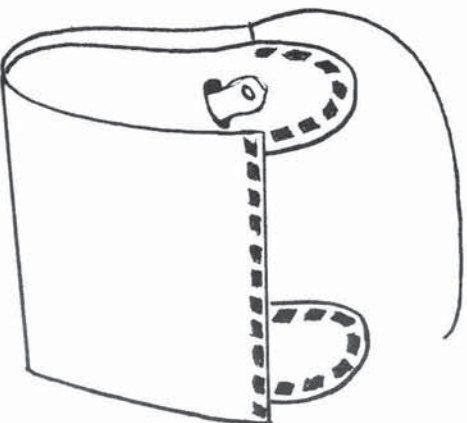

1. Cement gussets into position, (indicated above).
2. Punch and lace all outside edges, if a diamond lace is used, place a block of wood under outer edges as a punching base, for the round bottom gussets, use $\frac{3}{4}$ " or 1" round stick secured in a vice.
3. Attach lock, PRESTO LOCK No. 858 was used on this purse.
4. Attach shoulder strap.

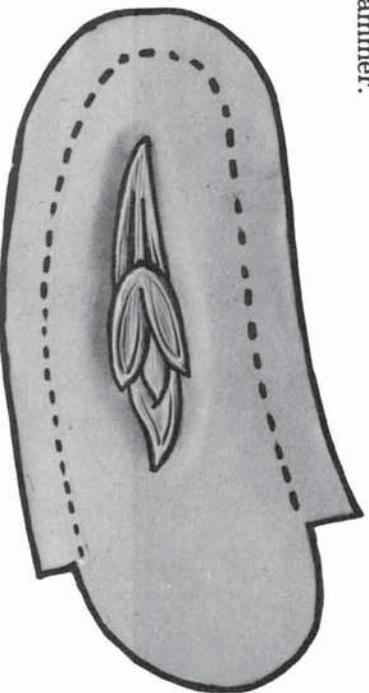

3 1/4"

13"

1 1/2"

SHOULDER STRAPS

Large Leather Utility Box

PROCEDURE

1. Make tracing and cutting patterns, since the utility box is one piece, trace the OUTSIDE black lines for the cutting pattern.
2. Cut project from heavy leather 8 to 9 oz. or heavier, the better for a firm unlined box.
3. Moisten leather with sponge, allowing moisture to penetrate, then let surface dry until it has ALMOST turned to the original color.
4. Transfer tracing design to cased leather, using hard drawing pencil 4-H or stylus.
5. Carve and stamp design, using actual size reproduction for your guidance.
6. Use woolskin pad to polish surface of the carving IMMEDIATELY after the carving is finished.
7. Slightly moisten FLESH side where you will channel. (Dots indicate center of the channel), see your craft dealer for channeling tool.
8. Use steel square as a straight edge and guide for the channeler.
9. After channeling is completed, use wide faced hammer to form the box.
10. Cement corners into position, place end pieces to INSIDE.
11. Sew or lace corners.



Completed Project

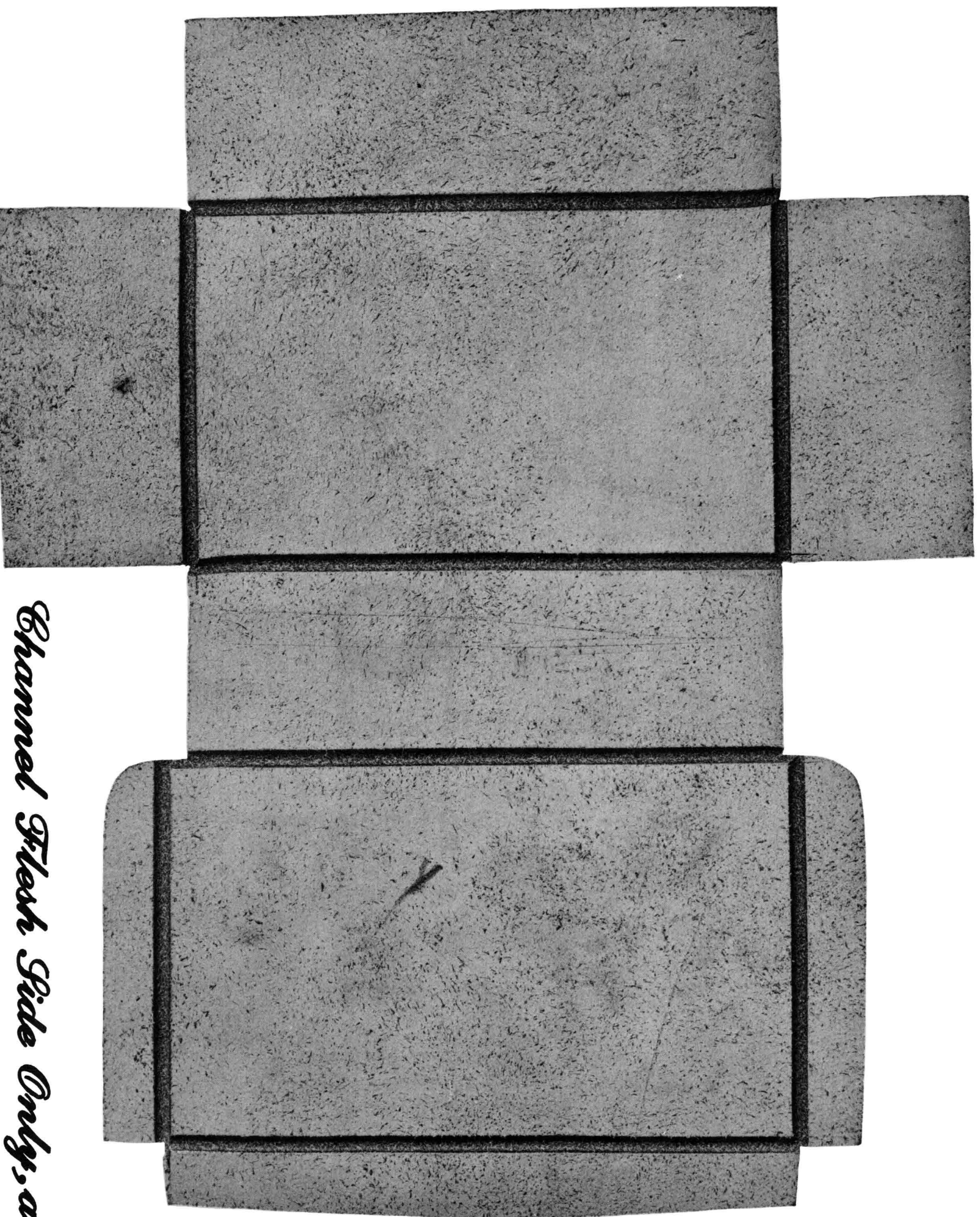

Channel Steel Side Only, as shown.

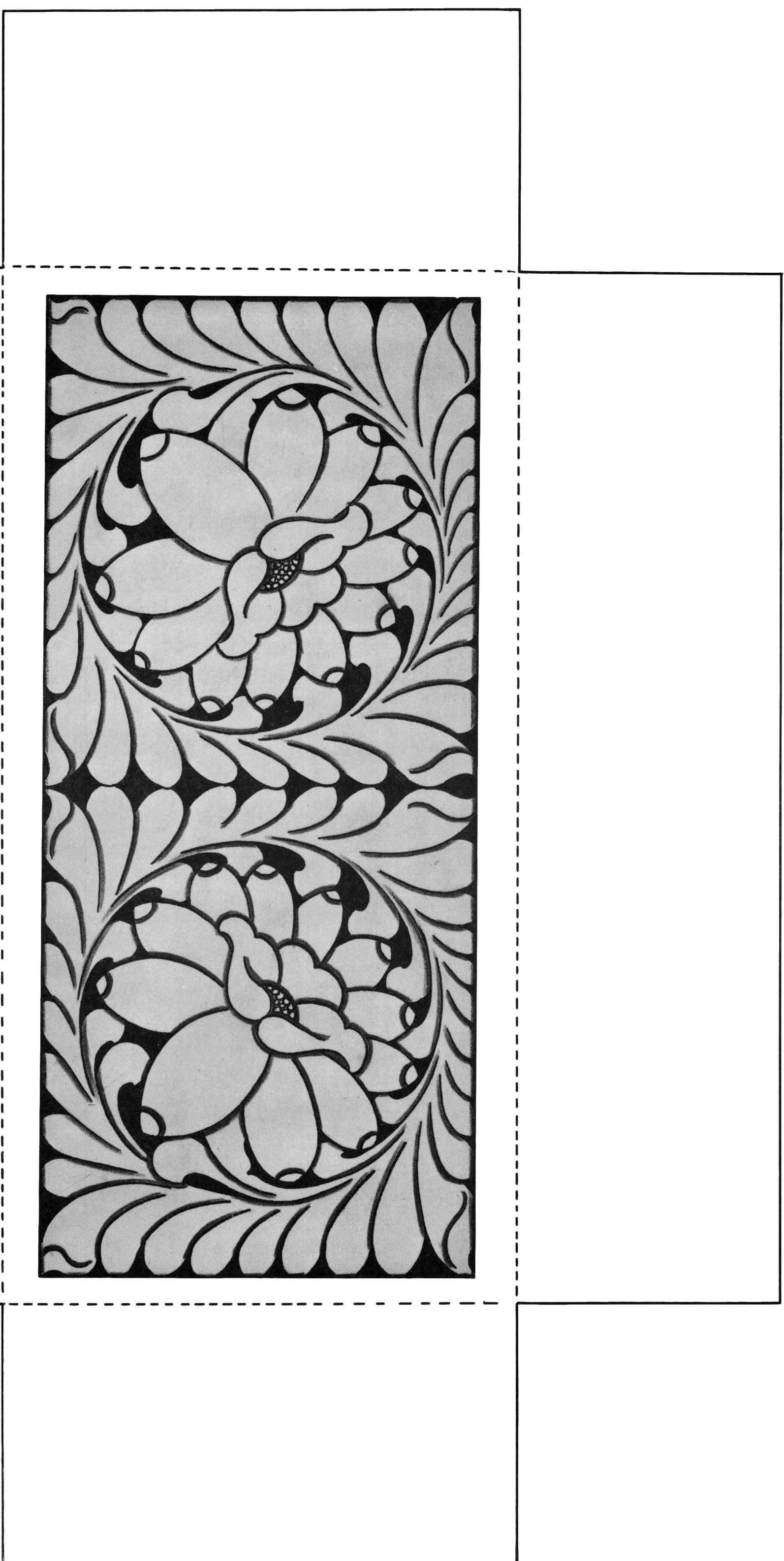

Alternate Design



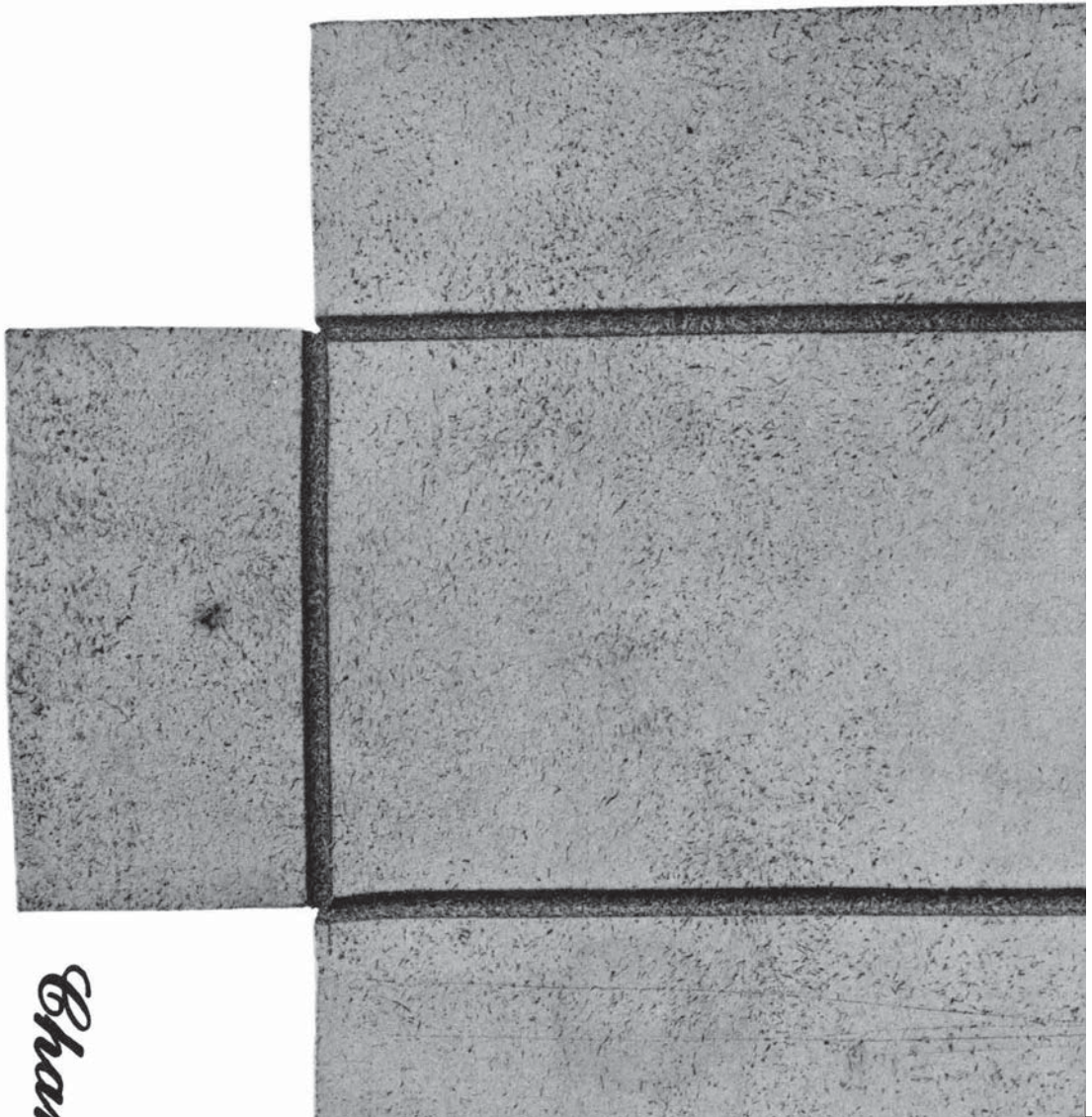

Shan

Completed Project

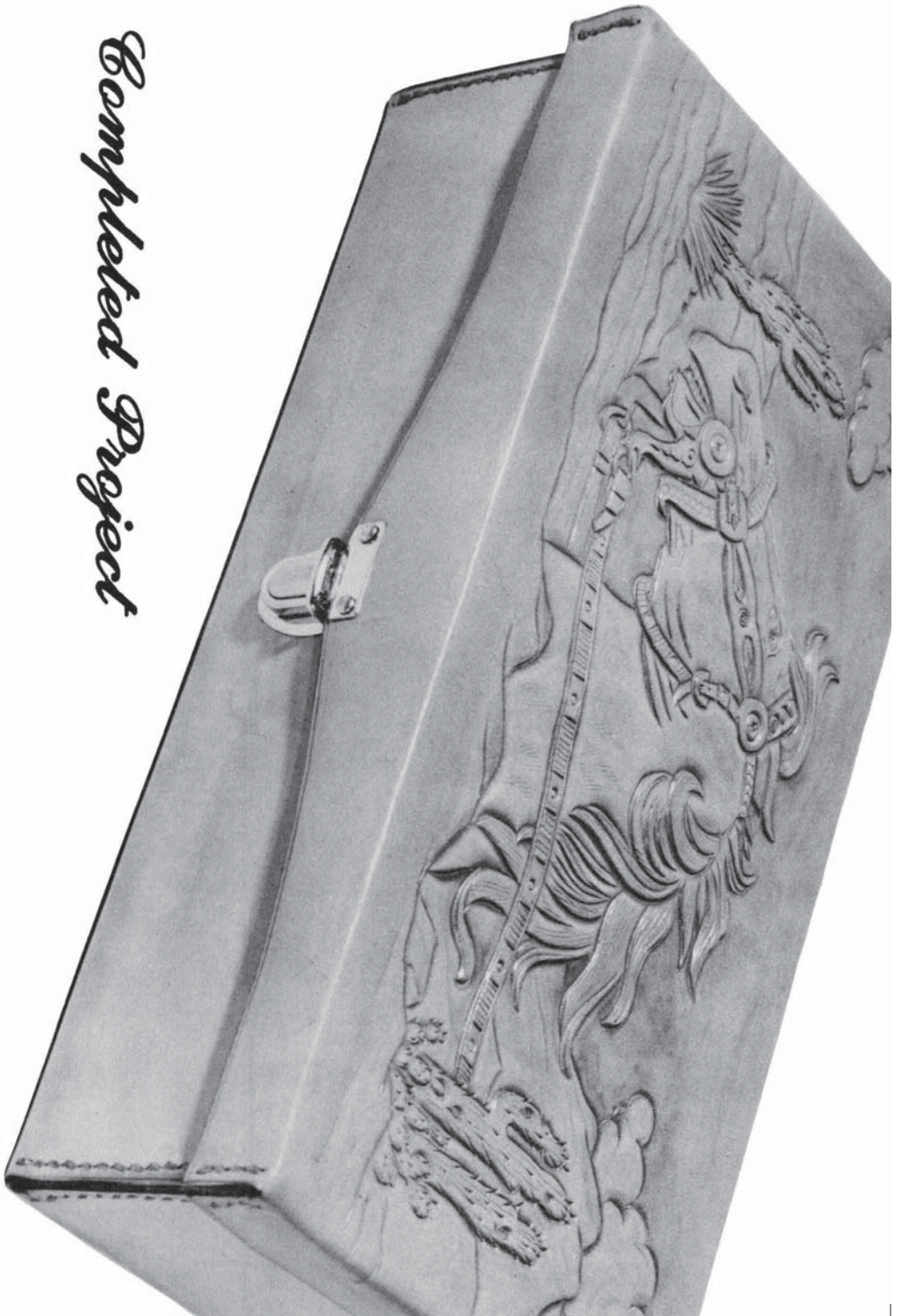

Large Leather Utility Box

PROCEDURE

1. Make tracing and cutting patterns, since the utility box is one piece, trace the **OUTSIDE** black lines for the cutting pattern.
2. Cut project from heavy leather 8 to 9 oz. or heavier, the better for a firm unlined box.
3. Moisten leather with sponge, allowing moisture to penetrate, then let surface dry until it has **ALMOST** turned to the original color.
4. Transfer tracing design to cased leather, using hard drawing pencil 4-H or stylus.
5. Carve and stamp design, using actual size reproduction for your guidance.
6. Use woolskin pad to polish surface of the carving **IMMEDIATELY** after the carving is finished.
7. Slightly moisten **FLESH** side where you will channel. (Dots indicate center of the channel), see your craft dealer for channeling tool.
8. Use steel square as a straight edge and guide for the channeler.
9. After channeling is completed, use wide faced hammer to form the box.
10. Cement corners into position, place end pieces to **INSIDE**.
11. Sew or lace corners.



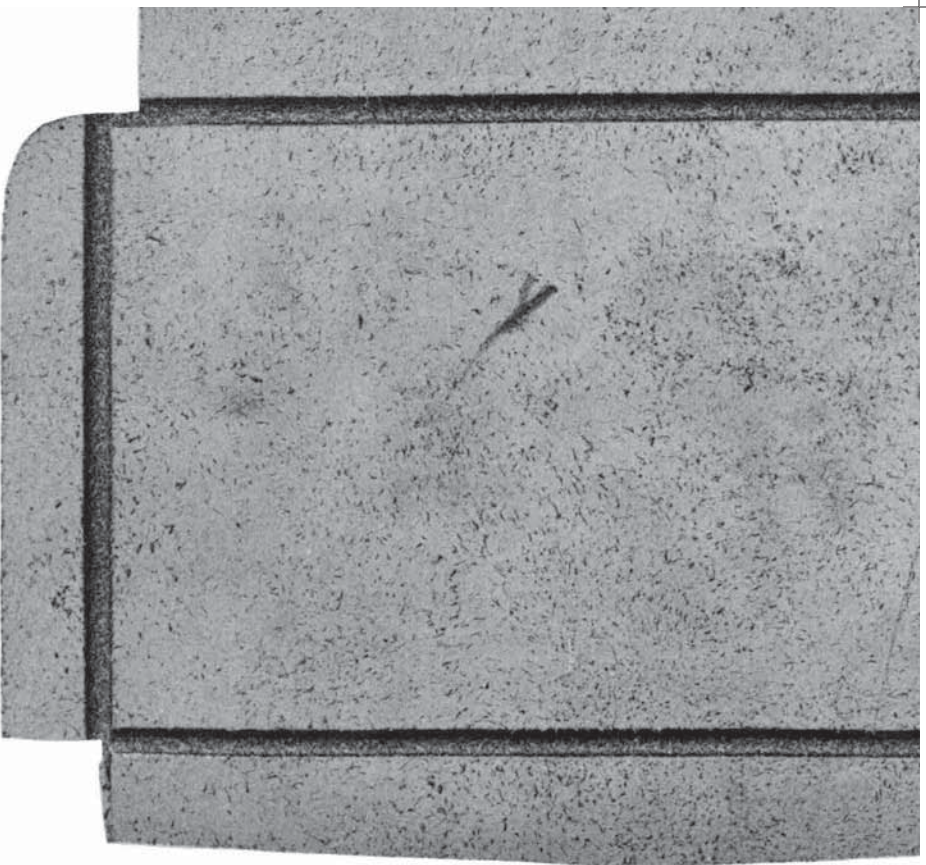

metal flesh side only, as shown.

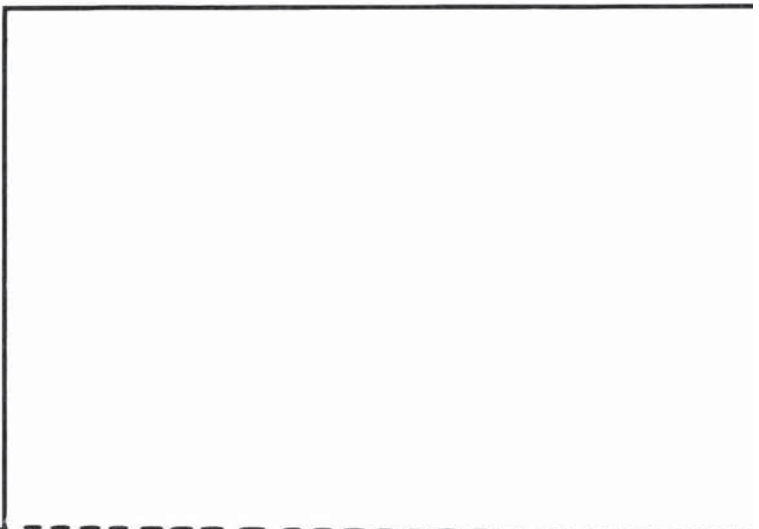
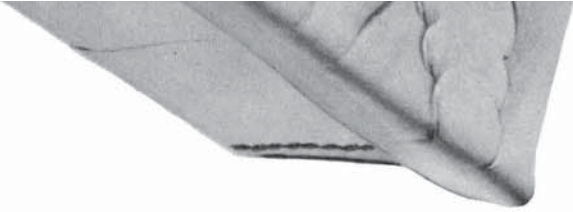

Allen

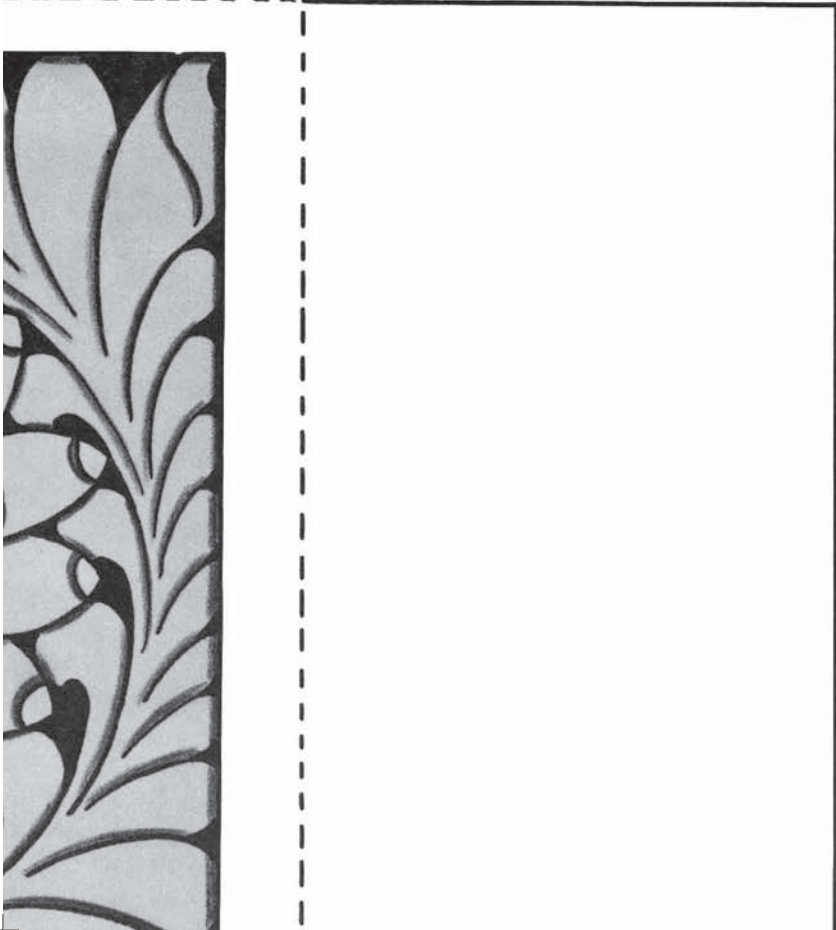

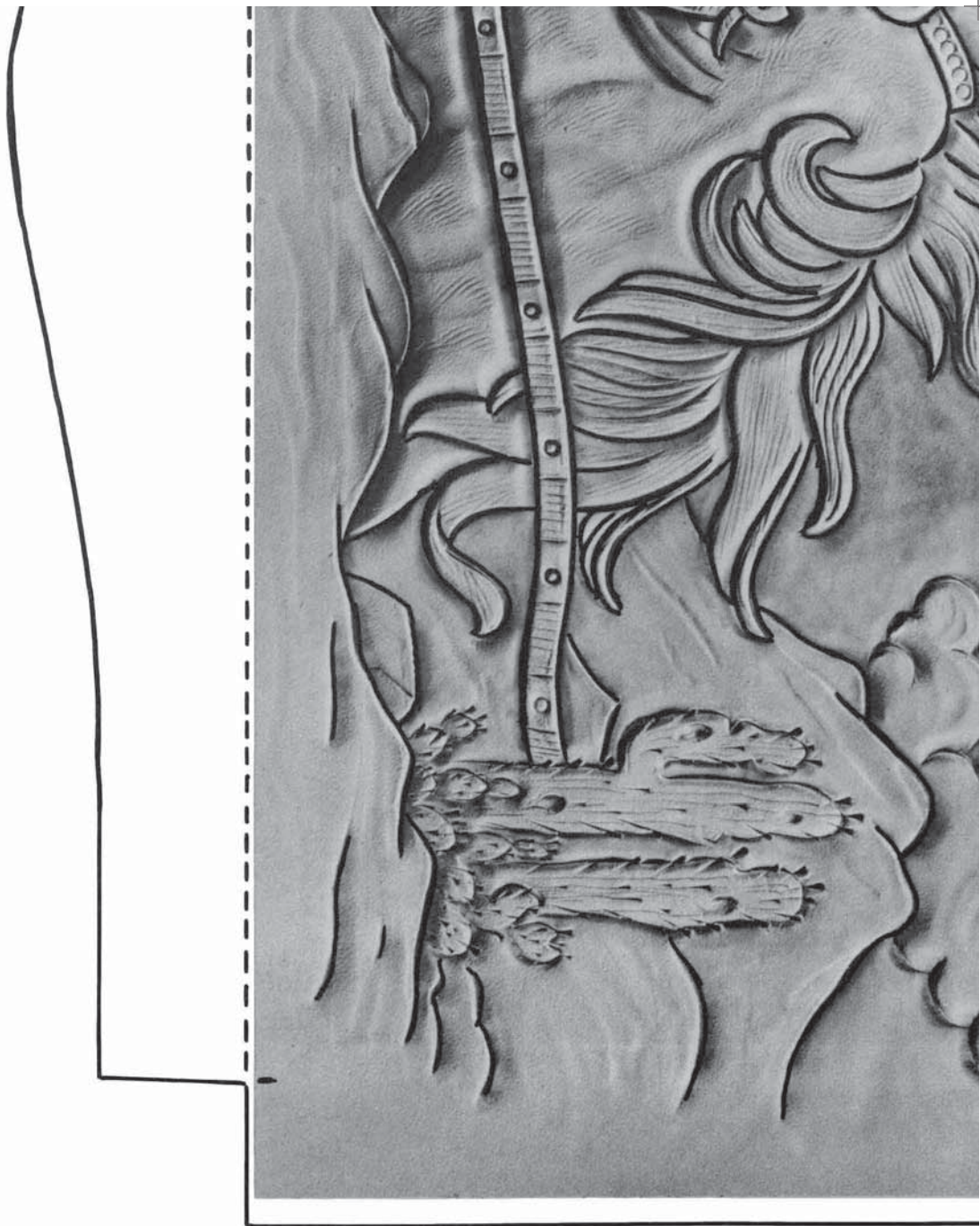

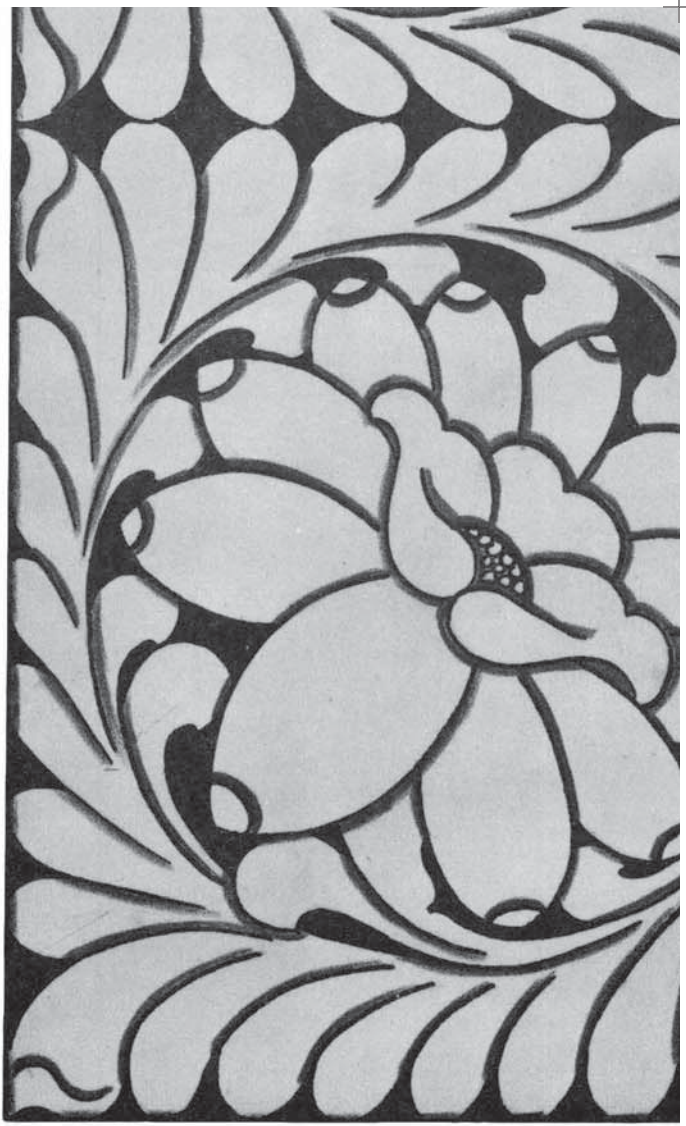

ate Design



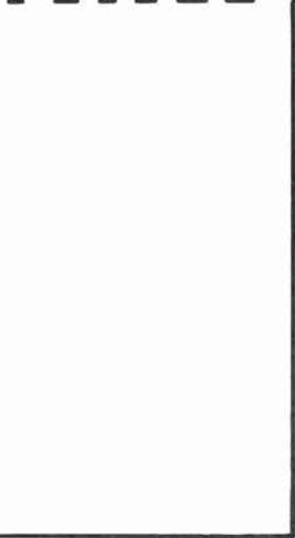
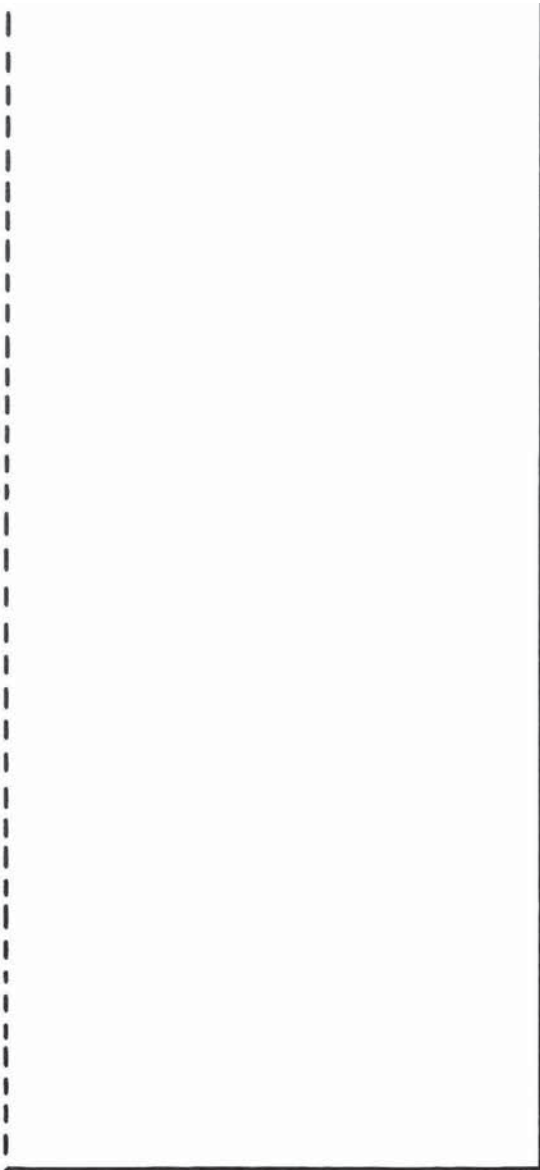

Writing Portfolio

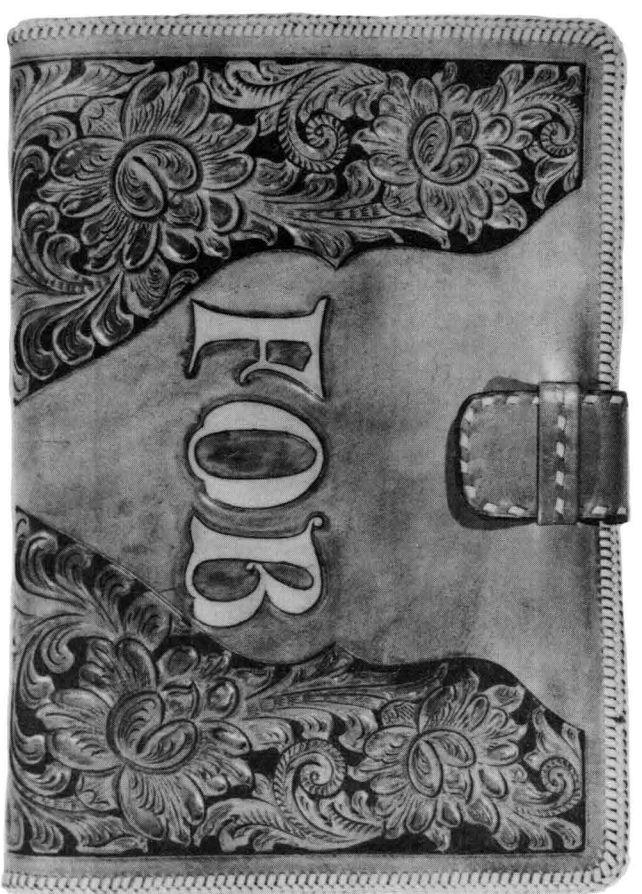

OUT SIDE FINISHED PORTFOLIO

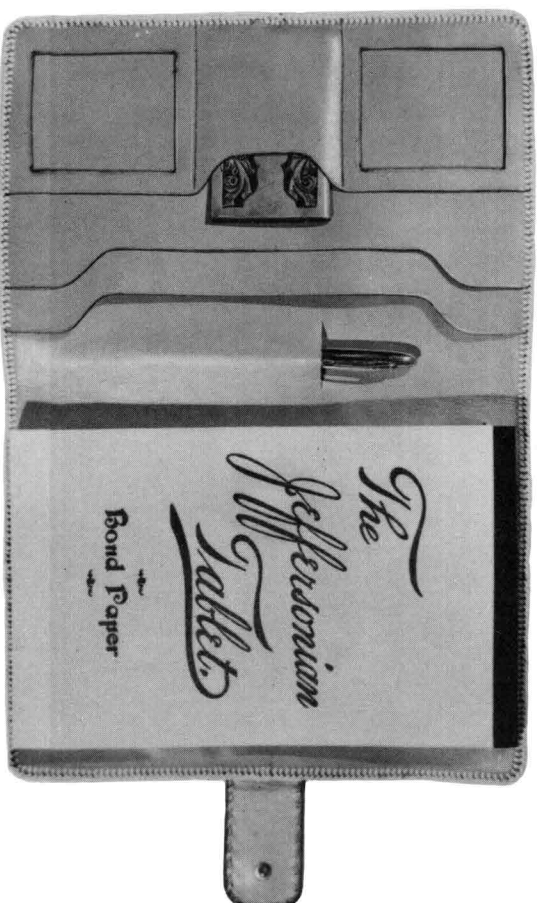

INSIDE

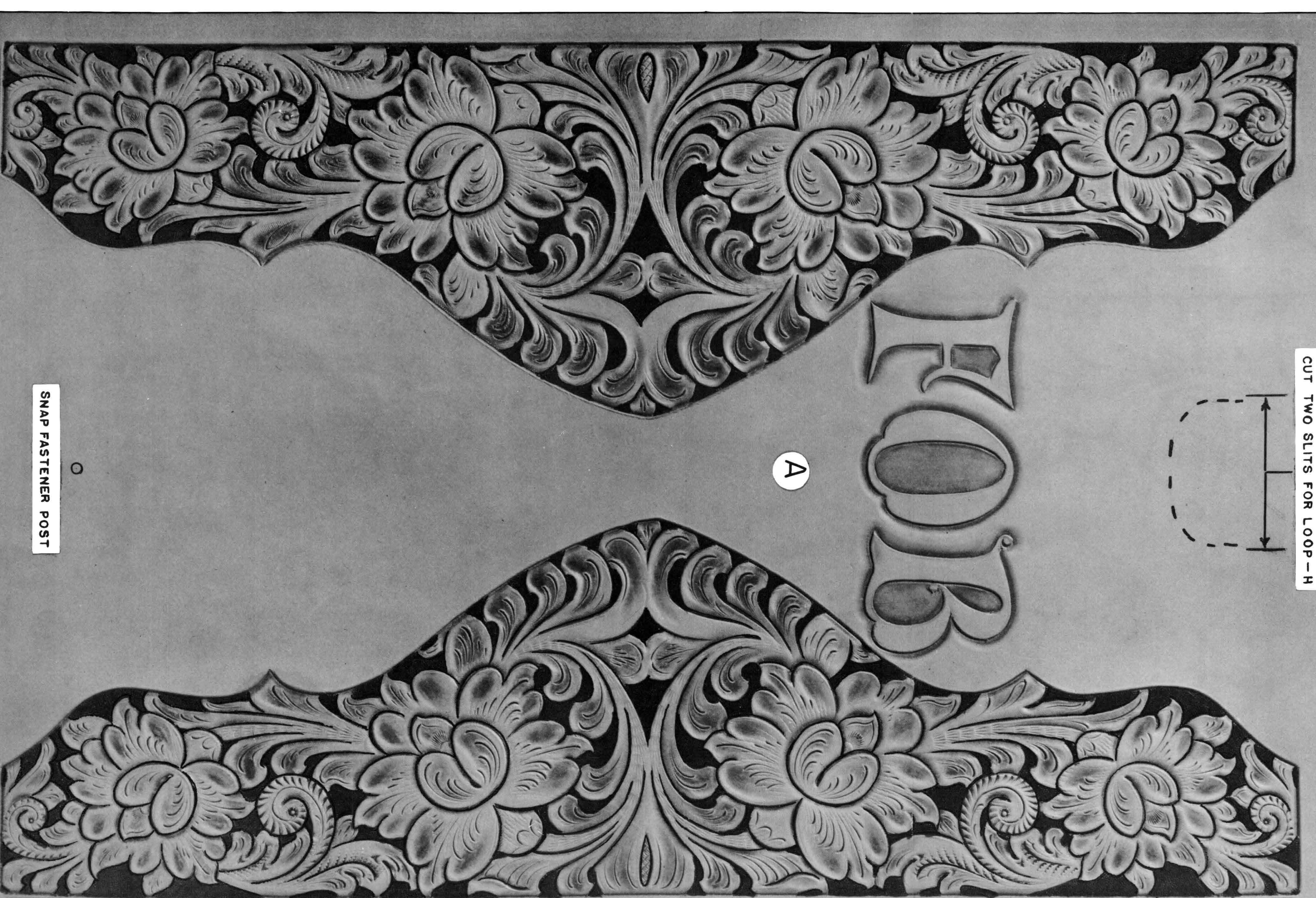

CUT TWO SLITS FOR LOOP—H

A

SNAP FASTENER POST

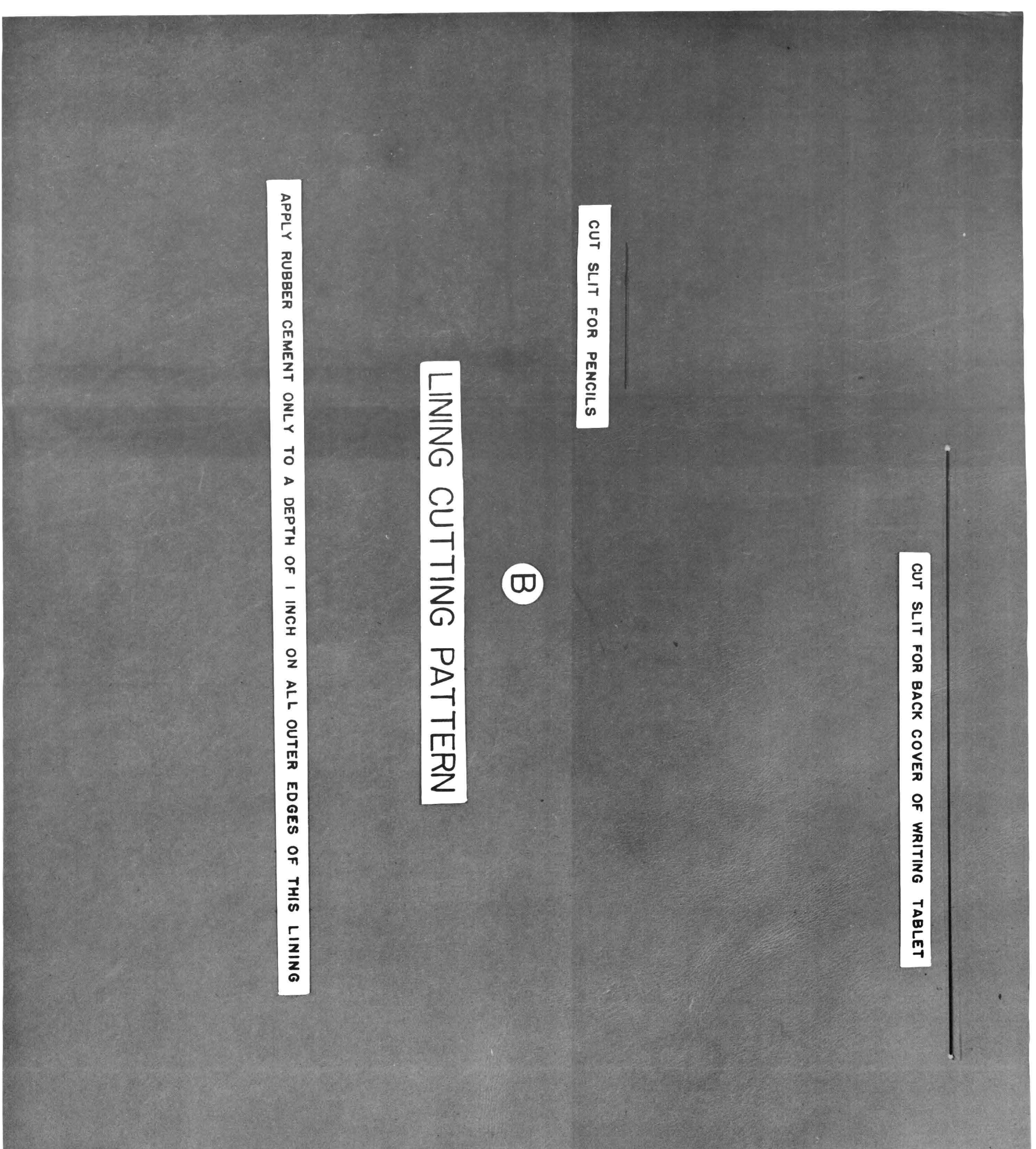

CUT SLIT FOR BACK COVER OF WRITING TABLET

CUT SLIT FOR PENCILS

B

LINING CUTTING PATTERN

APPLY RUBBER CEMENT ONLY TO A DEPTH OF 1 INCH ON ALL OUTER EDGES OF THIS LINING

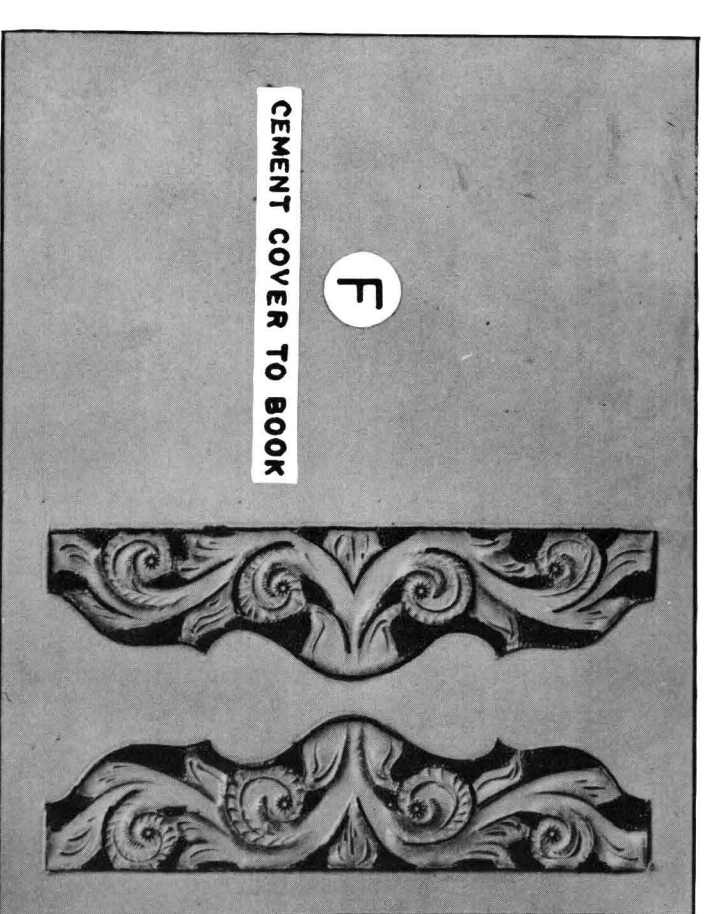

CEMENT COVER TO BOOK

F

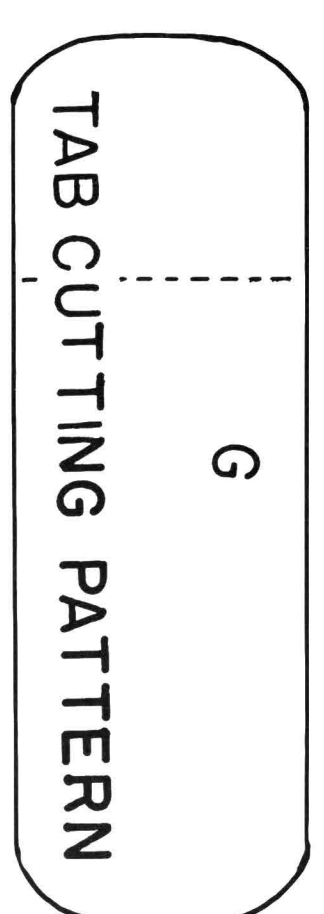

TAB CUTTING PATTERN

G

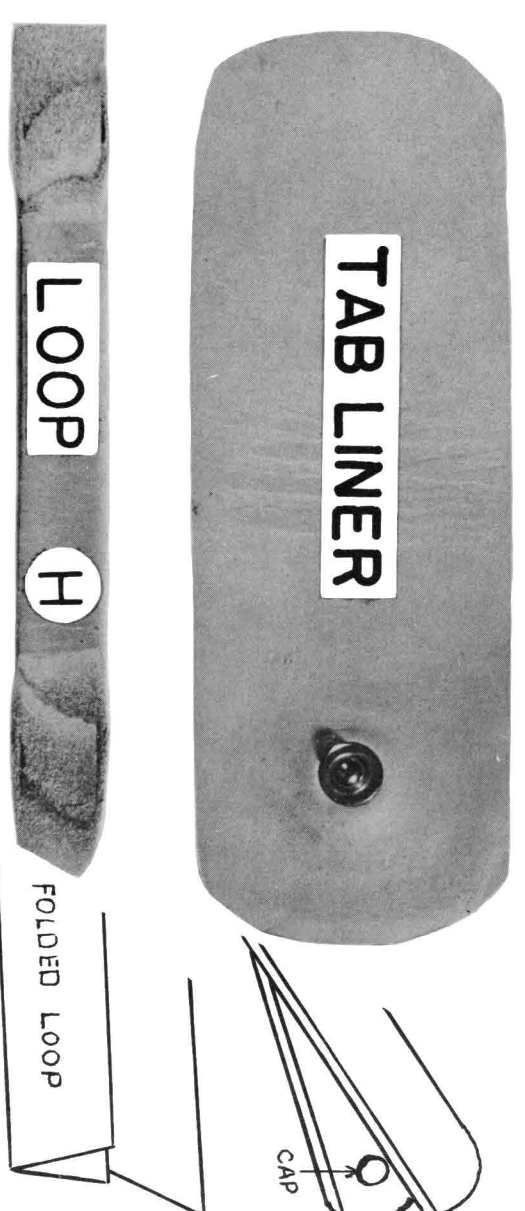

TAB LINER

LOOP

H

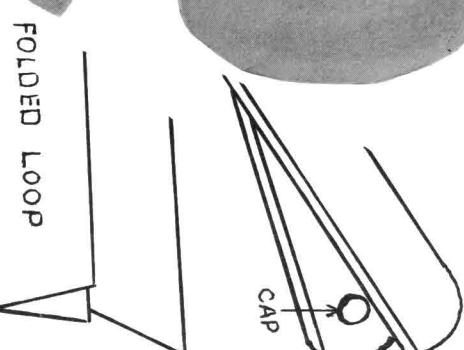

PROCEDURE

1. Make Cutting and Tracing patterns, place clear tracing paper over the photo, DO NOT trace ornamental cuts.
2. Cut project from leather, tooling calf or 3-4 oz. strap.
3. Case leather by dampening, allowing moisture to penetrate grain, allow top surface of leather to dry until it has ALMOST returned to original color.
4. Transfer tracing design to case leather using No. 4 H drawing pencil or stylus. DO NOT include ornamental cuts; these are added after stamping is done.

CARVING PROCEDURE

1. Swivel cut border lines, then flowers, leaves, stems, in this order.
2. Use large beveler No. 195 to bevel border lines, BEVEL TO INSIDE, which will raise the border as a protection from the stamp tools.
3. Pear-shading.
4. Barker tool on whisks.
5. Backgrounding.
6. Beveling, first use large beveler on all long straight cuts, next medium beveler.
7. Camouflage on all main stems.
8. Vaining.
9. Use swivel knife to ornamental cut design, study photo, this is a very important step and practice is essential.
10. Miles Foot on acanthus.
11. Stamp Seed Pod.

ASSEMBLY PROCEDURE

1. Cut out linings.
2. Skive all outer edges that are to be faced, crease and dye all exposed edges.
3. Secure snap fastener POST, as marked on pattern.
4. Make tab and loop, line tab, secure fastener cap to lining only for hidden button.
5. Sew tab to back piece A, sew under center of loop, which will next be covered with loop. After sewing, rubber cement will sufficiently hold loop ends, which should be shaved to tapered end, to avoid bumps.
6. Cement linings and pockets into position.
7. Lace edges.
8. Obtain small address book then glue or paste carved cover to the address book.
9. After case is laced, use polished stick or folder on inside of pockets to loosen cement which will allow maximum pocket expansion.
10. Purchase writing tablet approximately 5 3/4" x 8 1/2" x 1/4" or more thick, secure by sliding back cover of tablet into slot, also place pencil in slot, as shown on photograph.

POCKET CUTTING PATTERNS

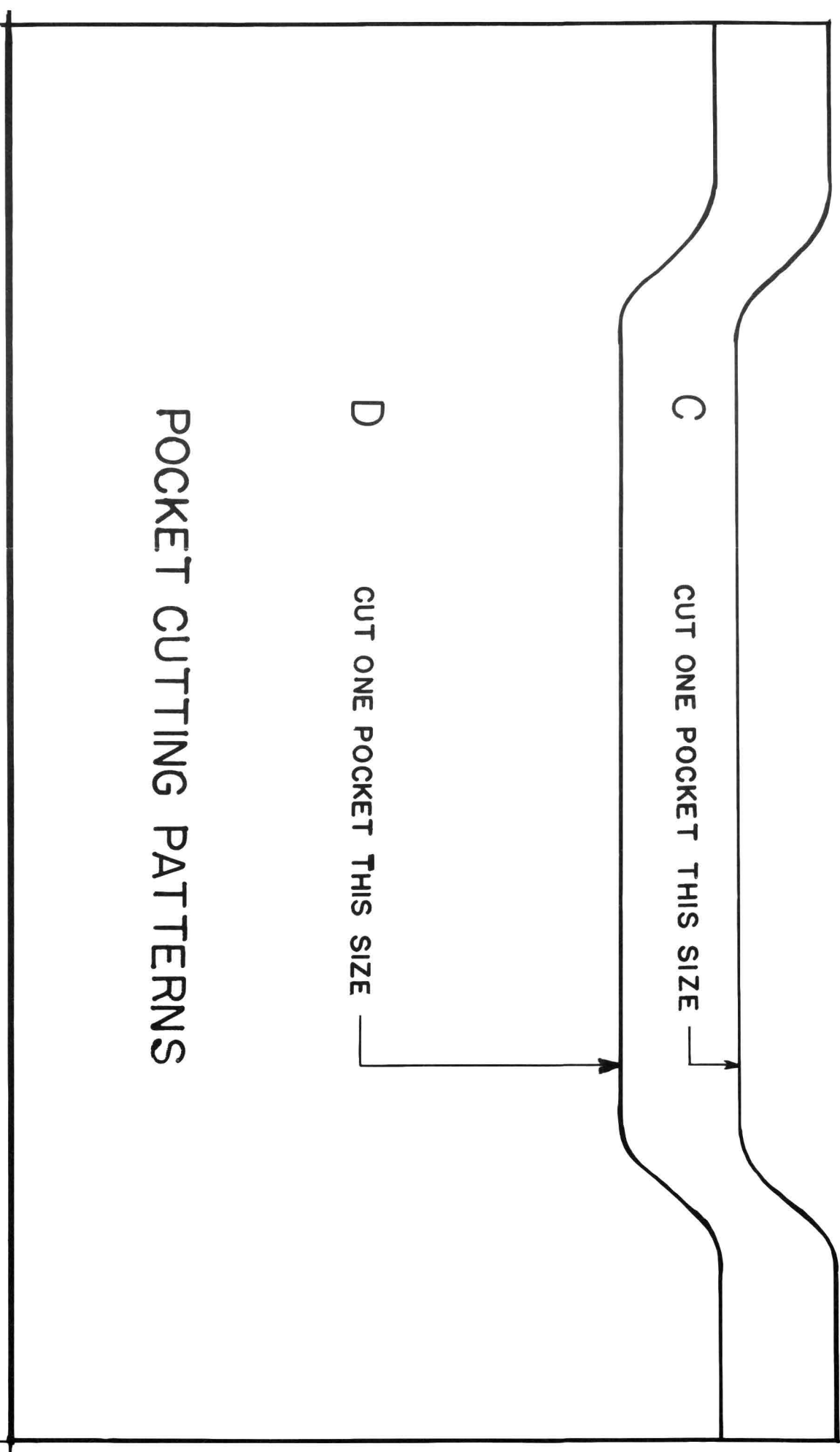

C CUT ONE POCKET THIS SIZE

D CUT ONE POCKET THIS SIZE



CUT OUT LIGHT AREAS THEN CREASE AND DYE ALL EDGES INSERT PLASTIC OR ISINGLASS OVER INDENTIFICATION AND PHOTO INDENTIFICATION CARD

SEW OR LACE ON DOTTED LINES TO FORM POCKET FOR ADDRESS BOOK

E

PHOTO

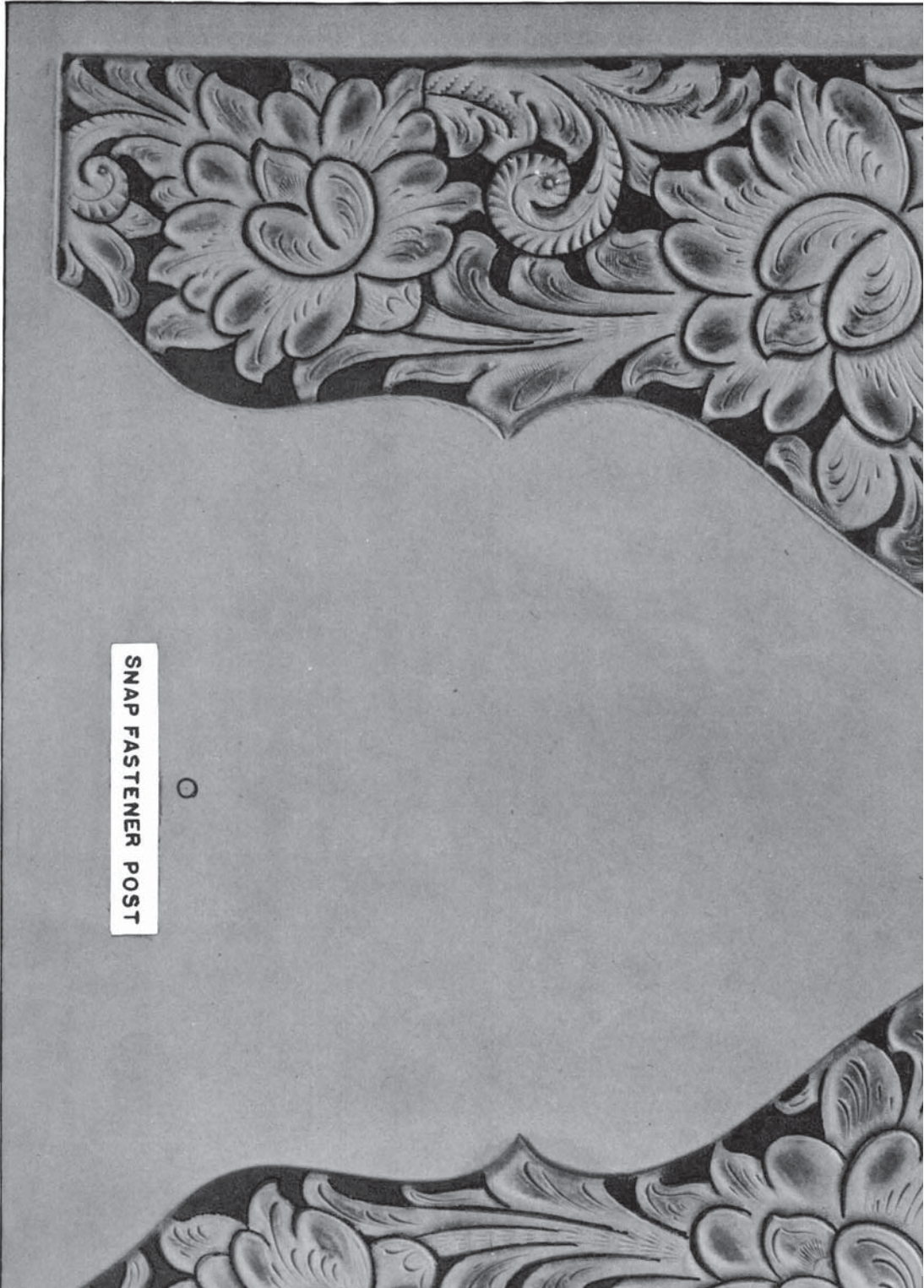

SNAP FASTENER POST





A

FEEDER

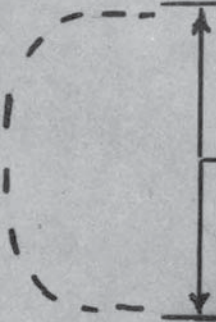

Writing Portfolio



OUT SIDE FINISHED PORTFOLIO



INSIDE

CUT TWO SLITS FOR LOOP - H

POCKET CUTTING PATTERNS

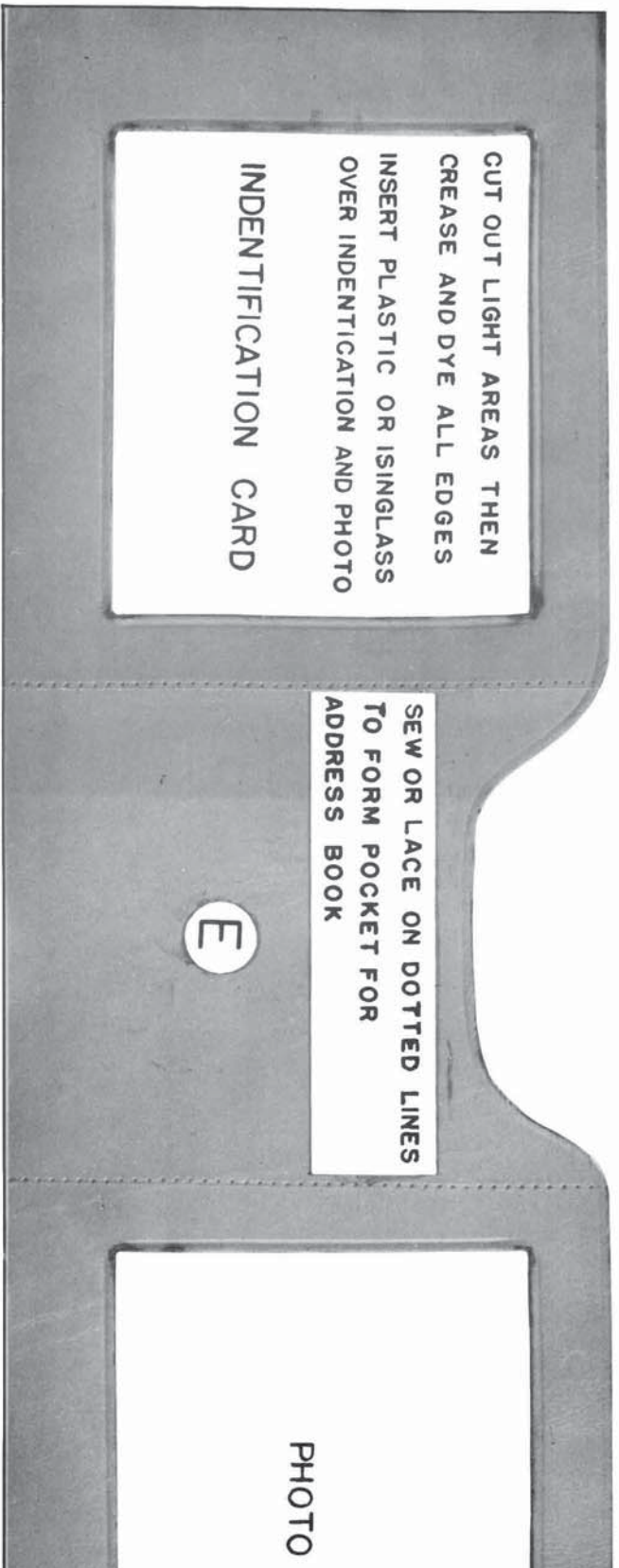



APPLY RUBBER CEMENT ONLY TO A DEPTH OF 1 INCH ON ALL OUTER EDGES OF THIS

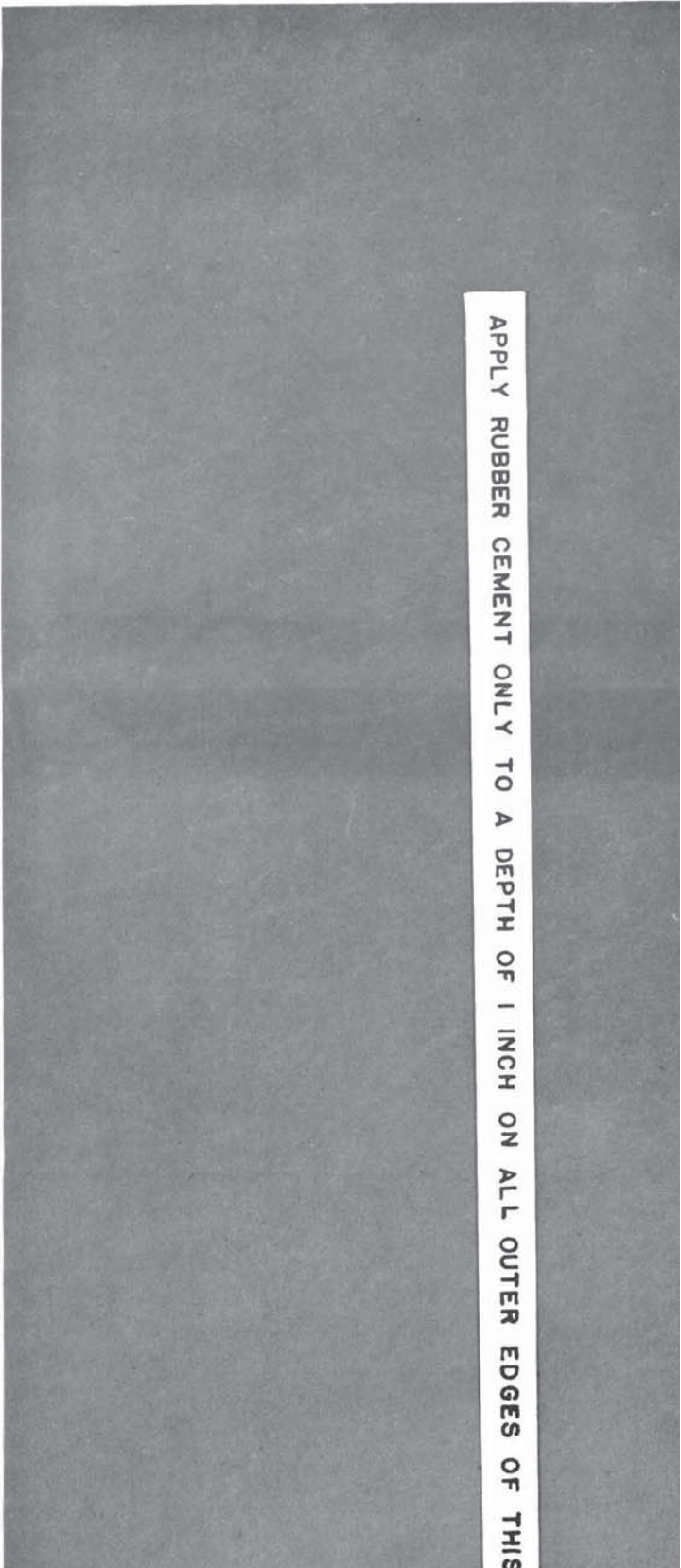

D CUT ONE POCKET THIS SIZE

C CUT ONE POCKET THIS SIZE

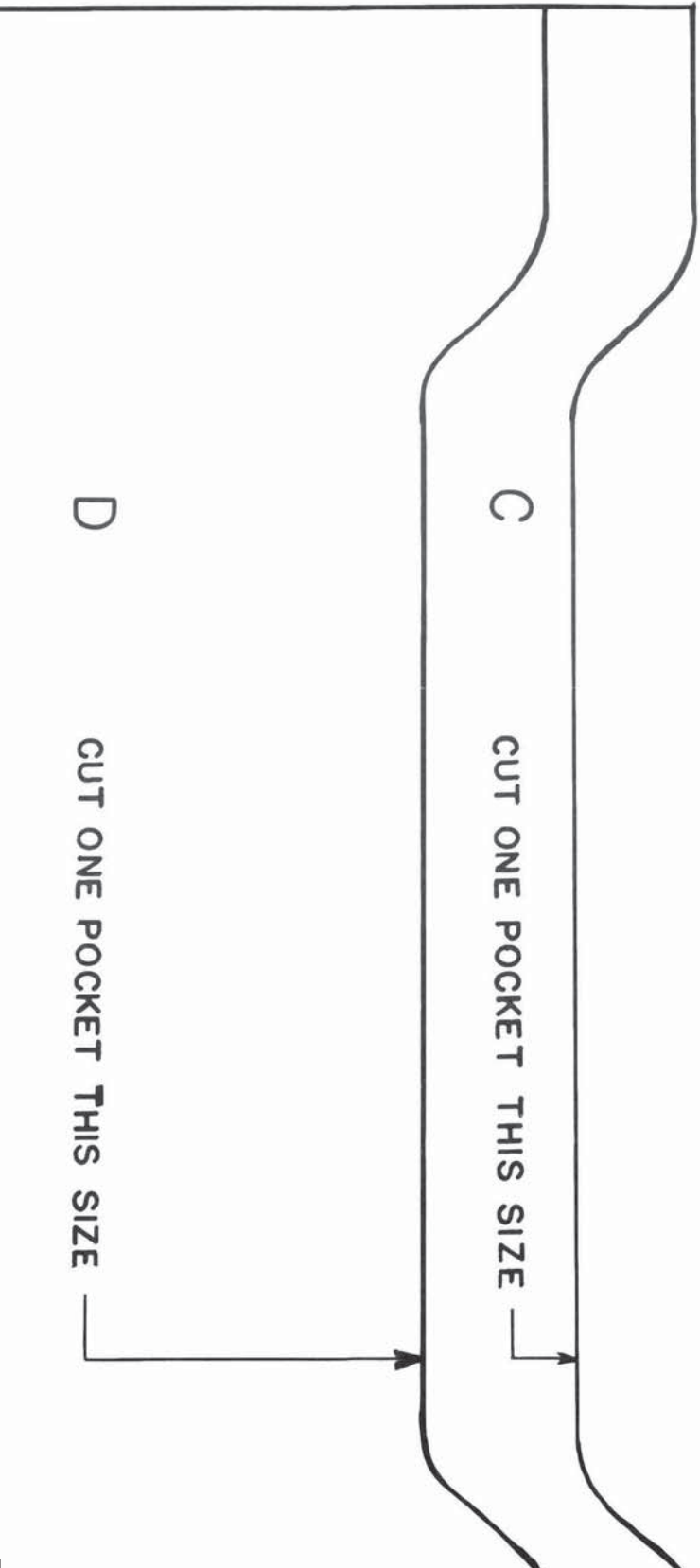

lio

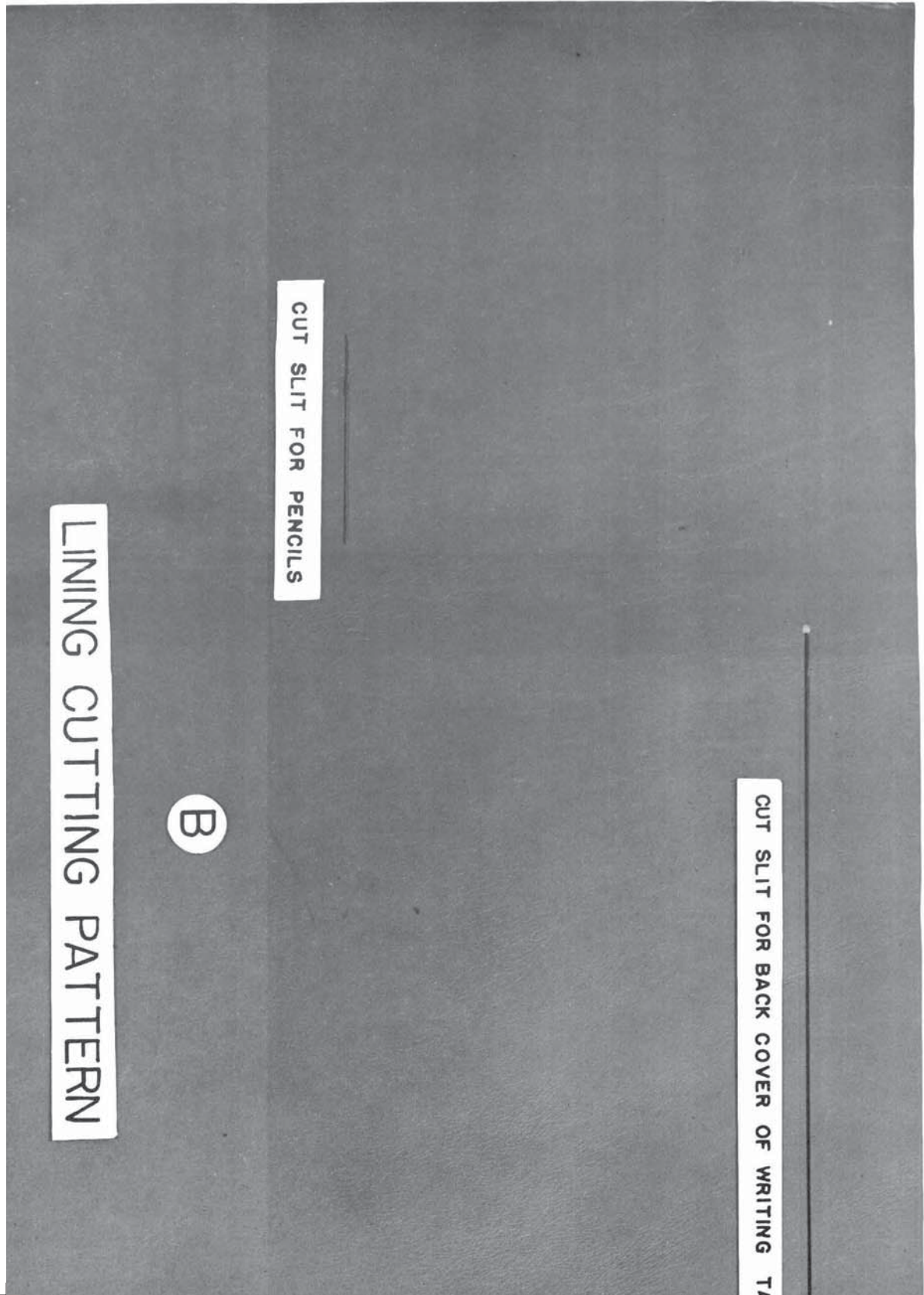
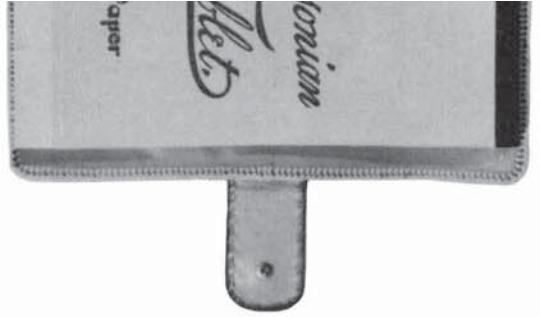

CUT SLIT FOR BACK COVER OF WRITING TA

CUT SLIT FOR PENCILS

LINING CUTTING PATTERN

B

2. Use large beveler No. 195 to bevel border lines, BEVEL TO INSIDE, which will raise the border as a protection from the stamp tools.
3. Pear-shading.
4. Barker tool on whirls.
5. Backrounding.
6. Beveling, first use large beveler on all long straight cuts, next medium beveler.
7. Camouflager on all main stems.
8. Veining.
9. Use swivel knife to ornamental cut design, study photo, this is a very important step and practice is essential.
10. Mules Foot on acanthus.
11. Stamp Seed Pod.

4. Make tab and loop, line tab, secure fastener cap to lining only for hidden button.
5. Sew tab to back piece A, sew under center of loop, which will next be covered with loop. After sewing, rubber cement will sufficiently hold loop ends, which should be skived to tapered end, to avoid bumps.
6. Cement linings and pockets into position.
7. Lace edges.
8. Obtain small address book then glue or paste carved cover to the address book.
9. After case is laced, use polished stick or folder on inside of pockets to loosen cement which will allow maximum pocket expansion.
10. Purchase writing tablet approximately $5\frac{3}{4}$ " x $8\frac{1}{2}$ " x $\frac{1}{4}$ " or more thick, secure by sliding back cover of tablet into slot, also place pencil in slot, as shown on photograph.

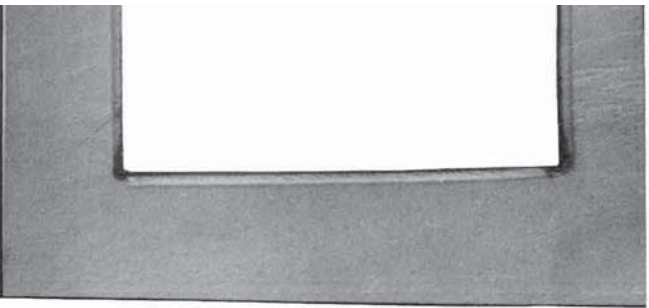

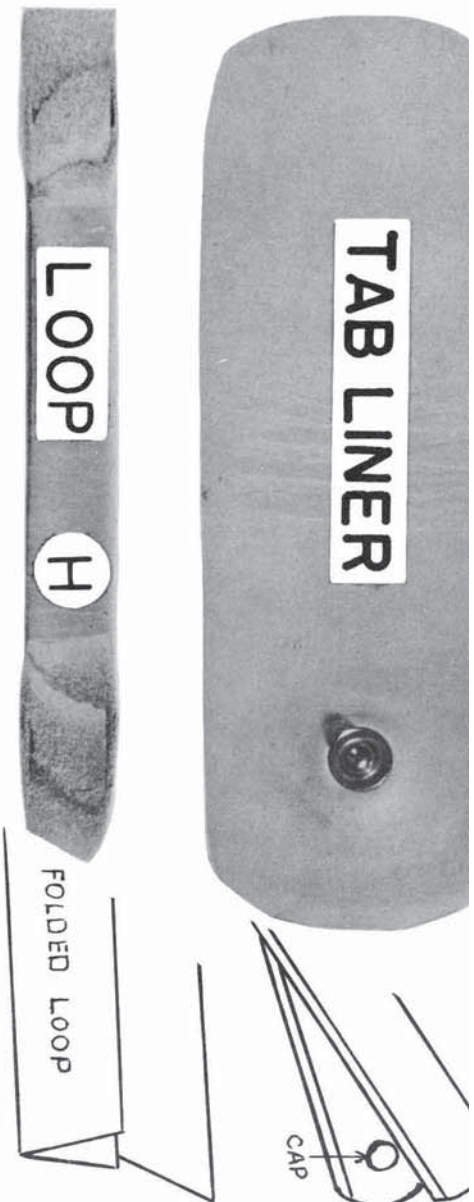
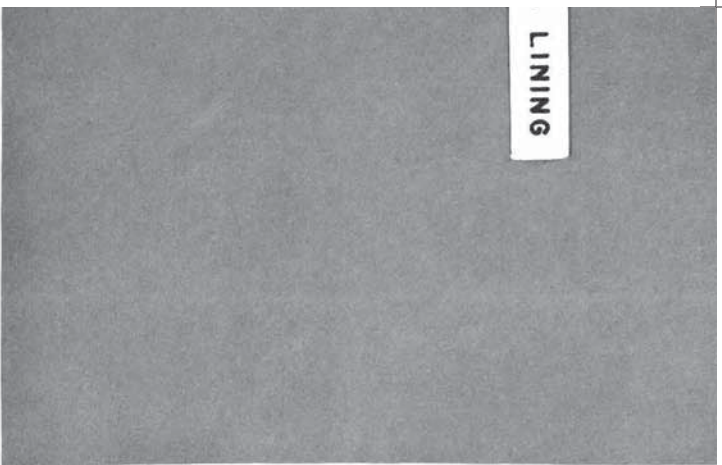

PROCEDURE

1. Make Cutting and Tracing patterns, place clear tracing paper over the photo, **DO NOT** trace ornamental cuts.
2. Cut project from leather, tooling calf or 3-4 oz. strap.
3. Case leather by dampening, allowing moisture to penetrate grain, allow top surface of leather to dry until it has **ALMOST** returned to original color.
4. Transfer tracing design to cased leather using No. 4 H drawing pencil or stylus. **DO NOT** include ornamental cuts, these are added after stamping is done.

CARVING PROCEDURE

1. Swivel cut border lines, then flowers, leaves, stems, in this order.

12. Use large or medium beveler to re-bevel down all parts of the design touching the border, being careful not to touch background with the beveling tool.
13. If initials are desired redampen that area and swivel cut outline of initials and tap bevel outlines.
14. Use modeling tool to depress background areas, (see photograph).

ASSEMBLY PROCEDURE

1. Cut out linings.
2. Skive all outer edges that are to be laced, crease and dye all exposed edges.
3. Secure snap fastener **POST**, as marked on pattern.

ABLET

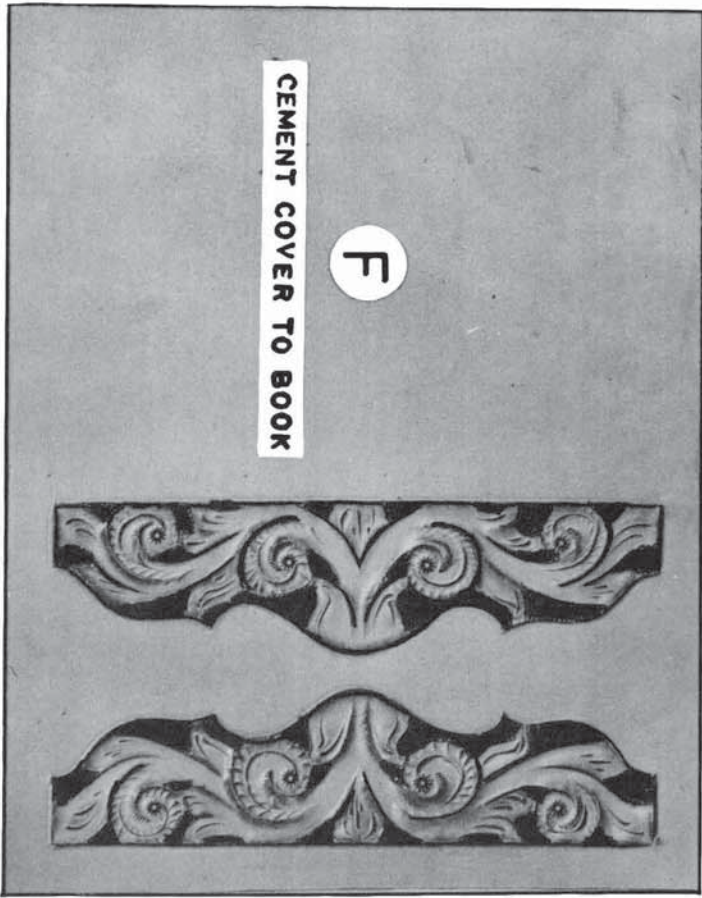

CEMENT COVER TO BOOK

F

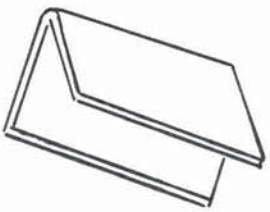

G

TAB CUTTING PATTERN

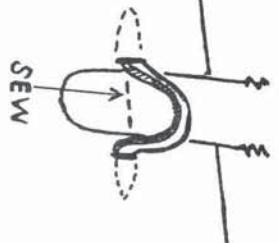

SEW

Medium & Small Leather Utility Boxes

PROCEDURE

1. Make tracing and cutting patterns, since the utility box is one piece, trace the **OUTSIDE** black lines for the cutting pattern.
2. Cut project from heavy leather 8 to 9 oz. or heavier, the better for a firm unlined box.
3. Moisten leather with sponge, allowing moisture to penetrate, then let surface dry until it has **ALMOST** turned to the original color.
4. Transfer tracing design to cased leather, using hard drawing pencil 4H or stylus.
5. Carve and stamp design, using actual size reproduction for your guidance.
6. Use wooskin pad to polish surface of the carving **IMMEDIATELY** after the carving is finished.
7. Slightly moisten **FLESH** side where you will channel. (Dots indicate center of the channel), see your craft dealer for channeling tool.
8. Use steel square as a straight edge and guide for the channeler.
9. After channeling is completed, use wide faced hammer to form the box.
10. Cement corners into position, place end pieces to **INSIDE**.
11. Sew or lace corners.



Completed Project

Completed Project

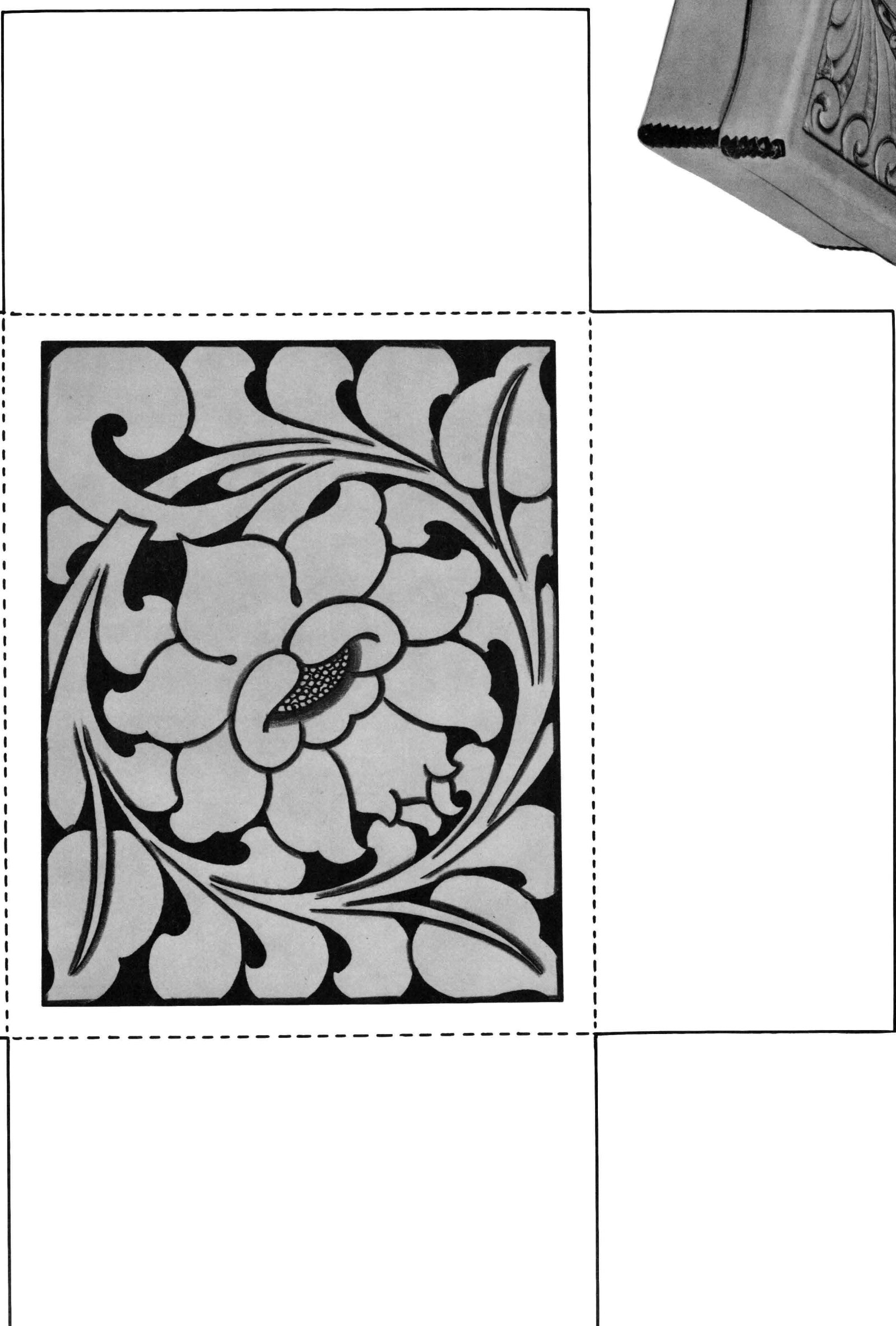
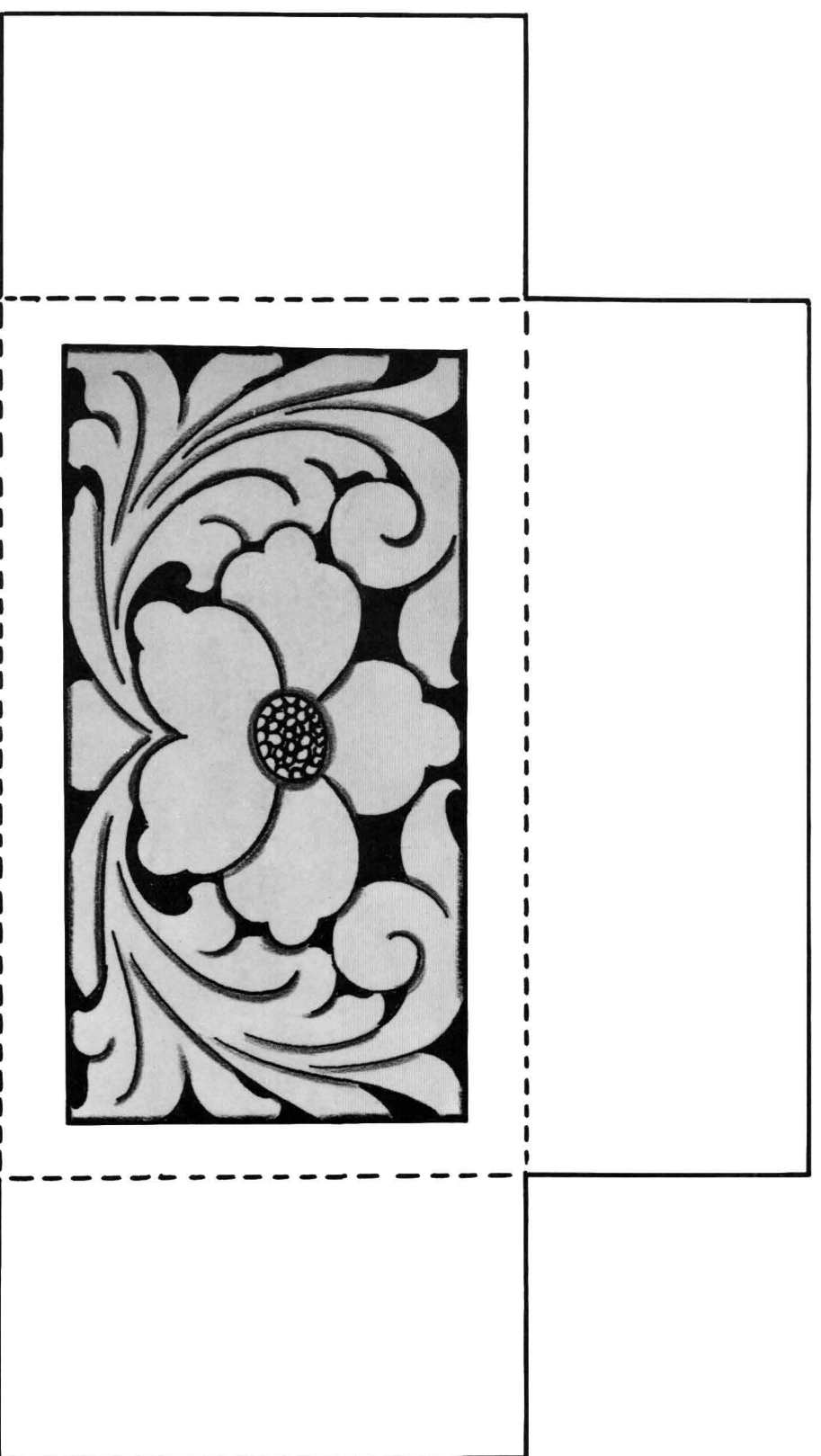
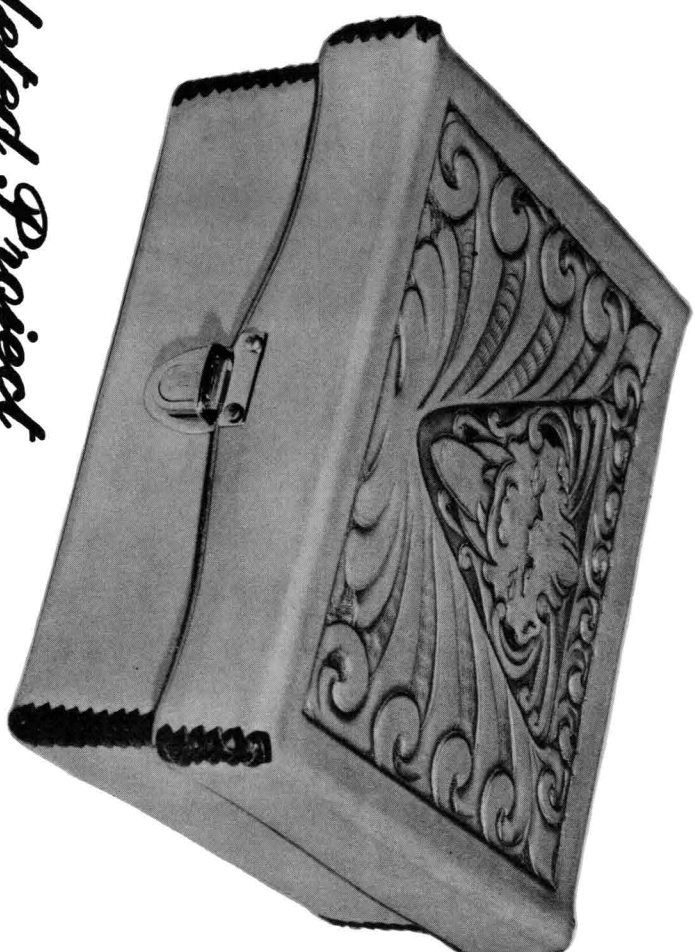

Alternate Design

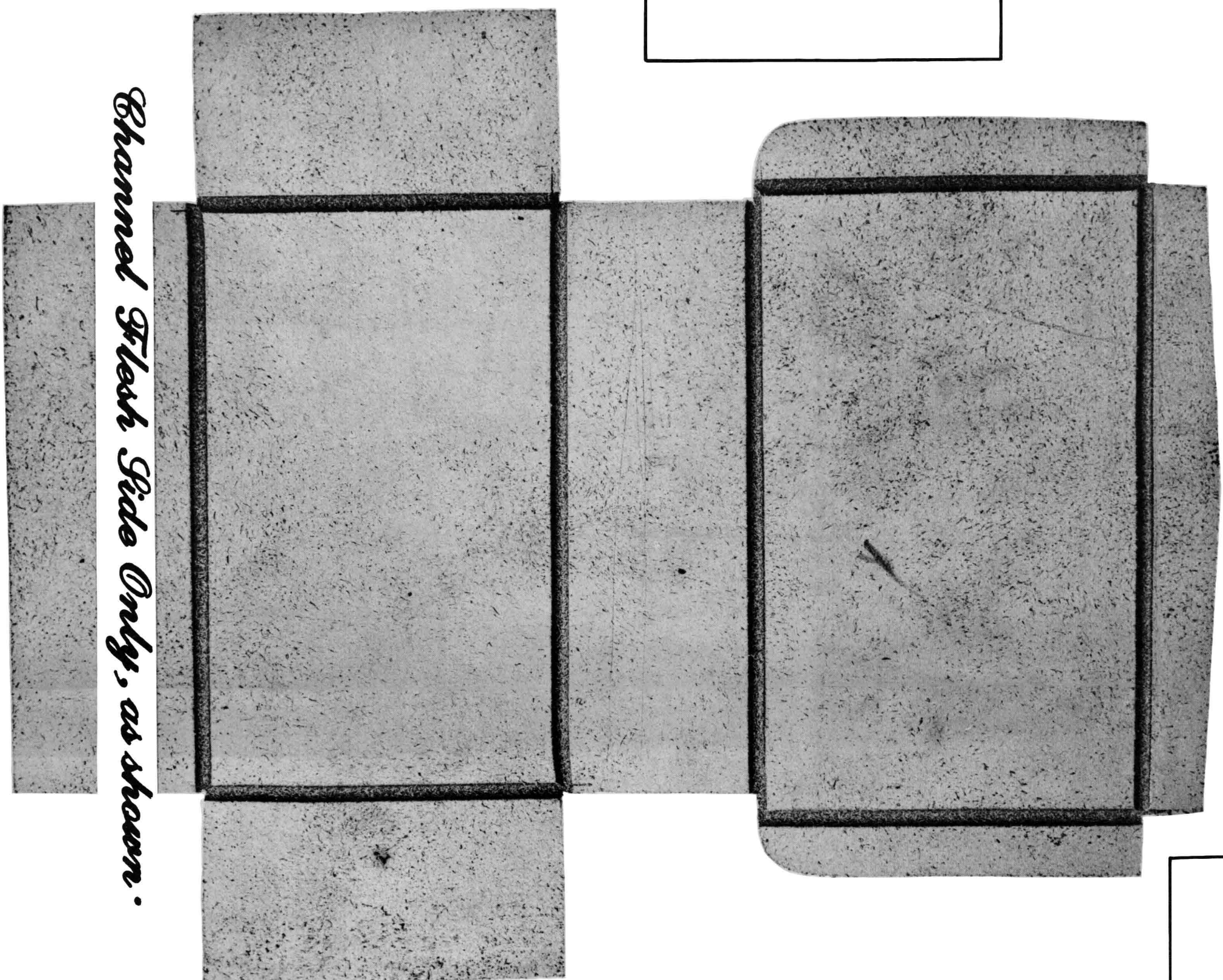

Channel Slight Side Only, as shown.



1. Slightly uneven fabric size where you will channel. (Dots indicate center of the channel), see your craft dealer for channeling tool.

8. Use steel square as a straight edge and guide for the channeler.

9. After channeling is completed, use wide faced hammer to form the box.

10. Cement corners into position, place end pieces to **INSIDE**.

11. Sew or lace corners.



Completed

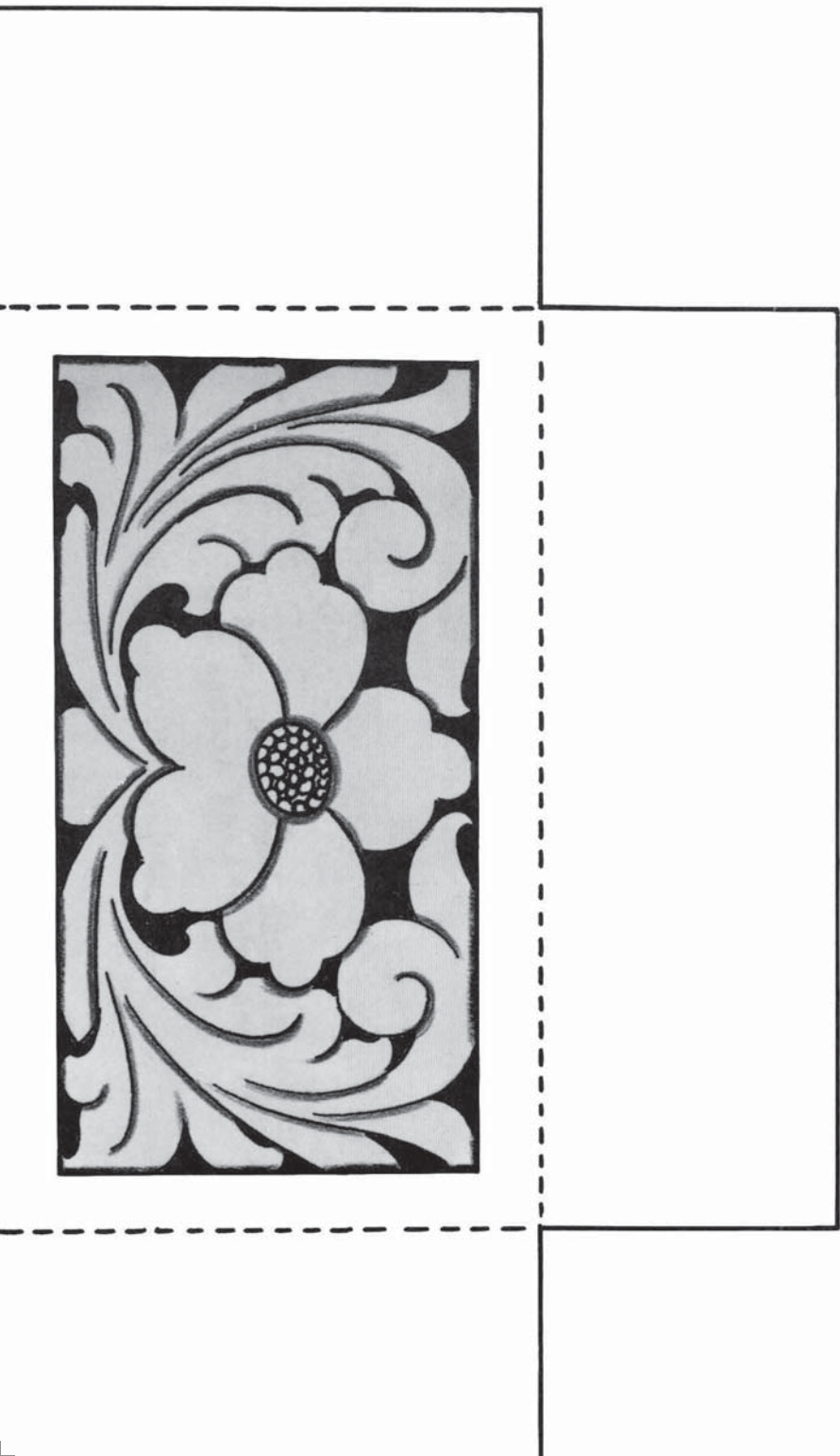

Medium & Small Leather Utility Box

PROCEDURE

1. Make tracing and cutting patterns, since the utility box is one piece, trace the **OUTSIDE** black lines for the cutting pattern.
2. Cut project from heavy leather 8 to 9 oz. or heavier, the better for a firm unlined box.
3. Moisten leather with sponge, allowing moisture to penetrate, then let surface dry until it has **ALMOST** turned to the original color.
4. Transfer tracing design to cased leather, using hard drawing pencil 4-H or stylus.
5. Carve and stamp design, using actual size reproduction for your guidance.
6. Use woolskin pad to polish surface of the carving **IMMEDIATELY** after the carving is finished.

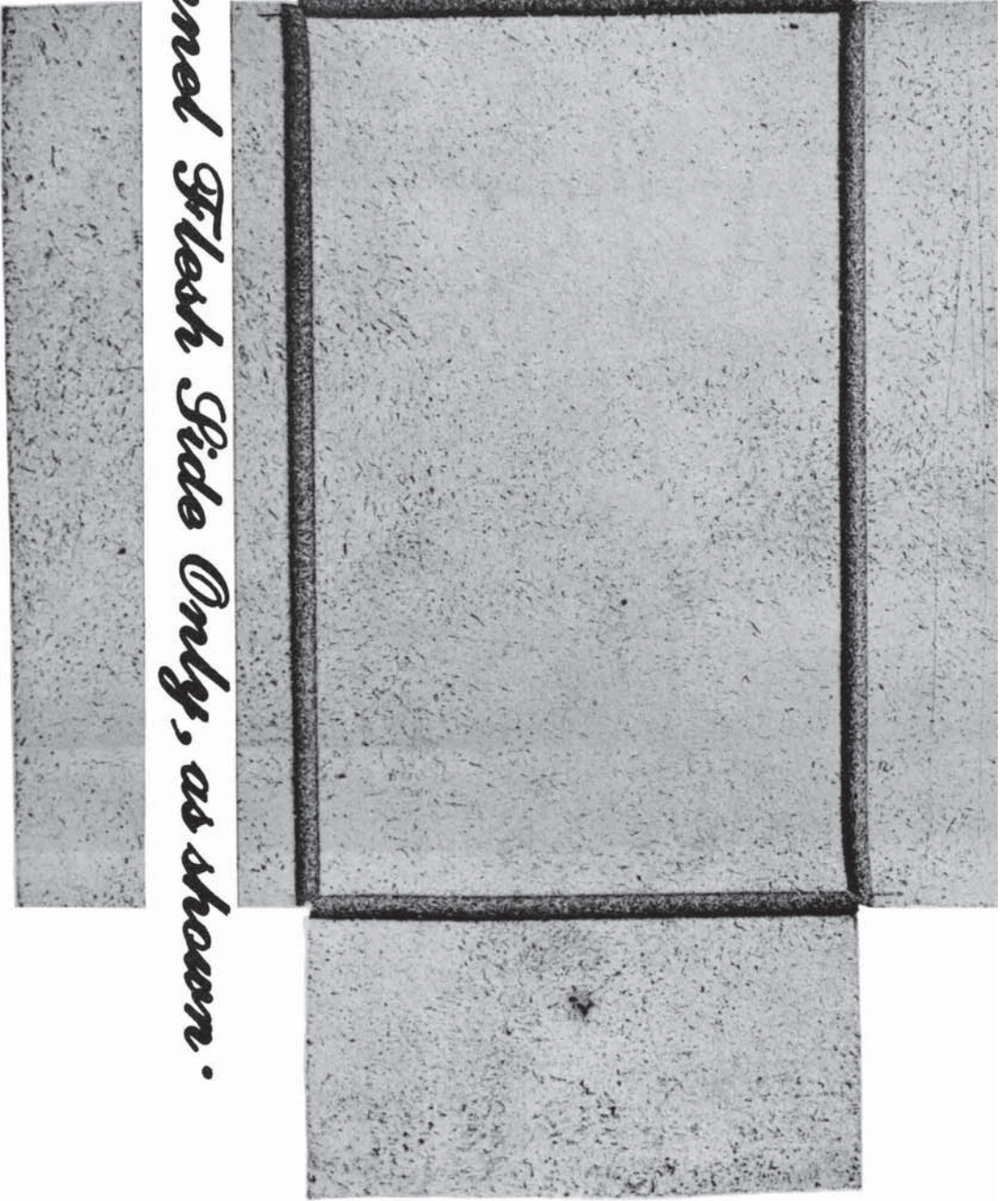

Channel Flash Side Only, as shown.

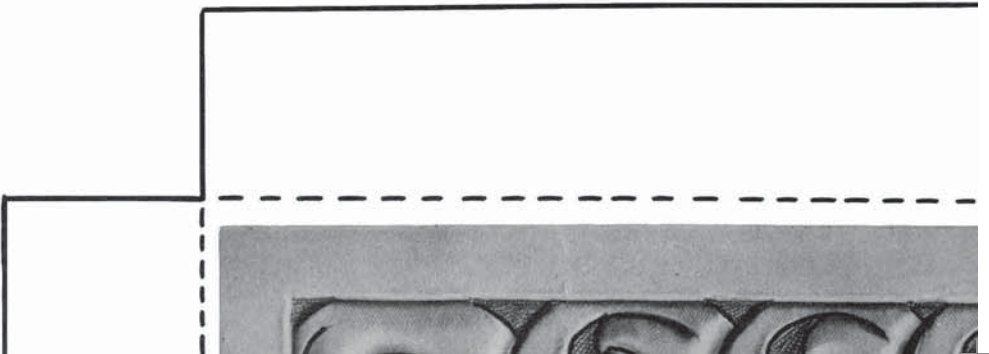



Project

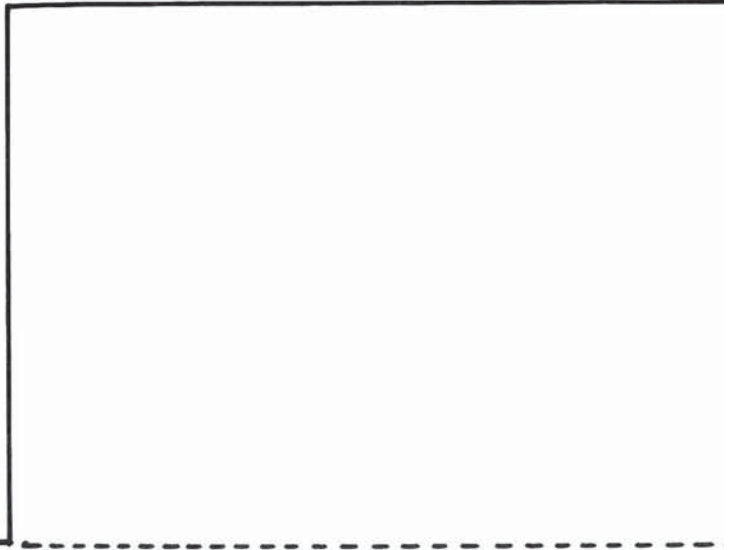
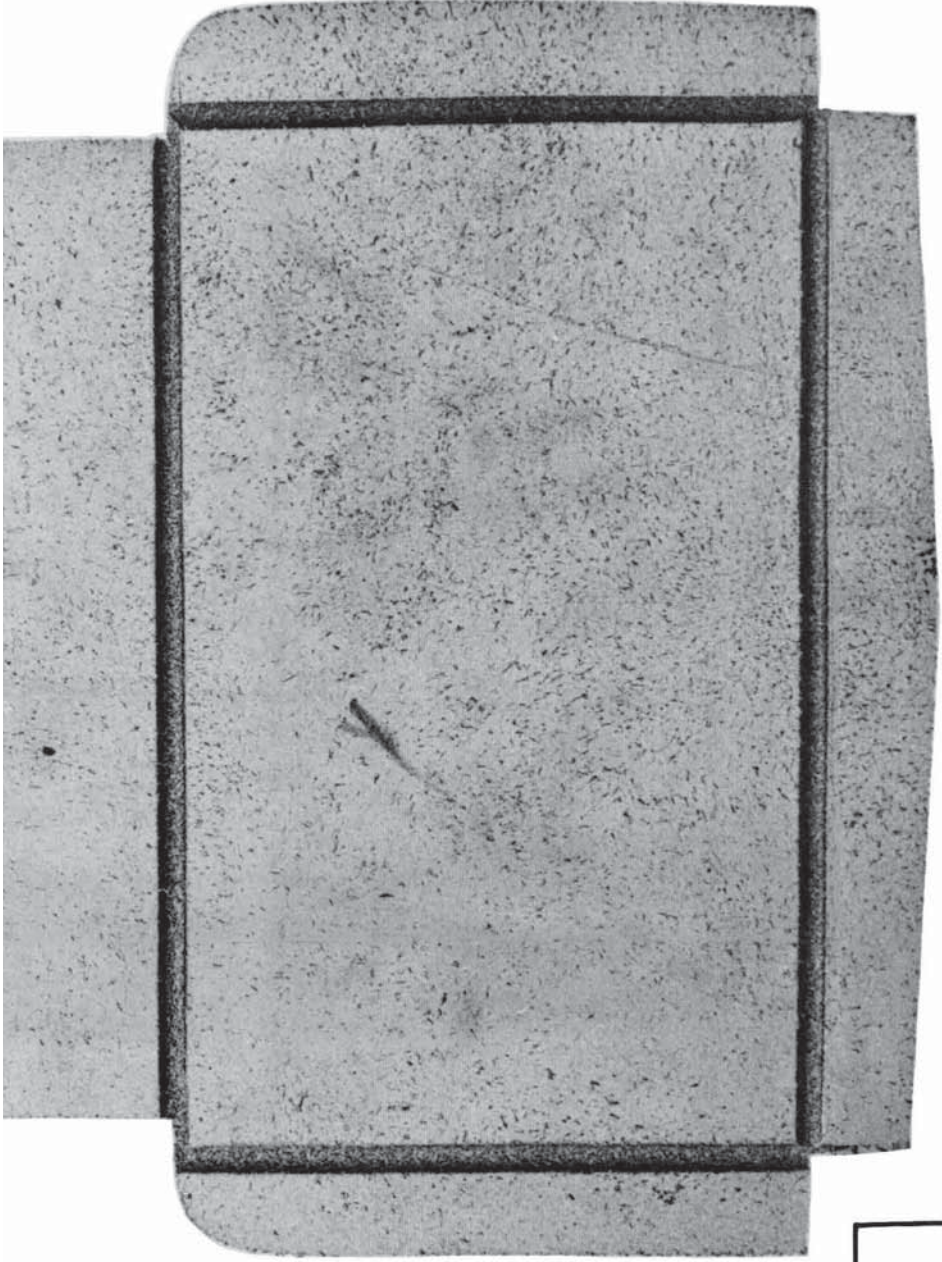

Completed Project

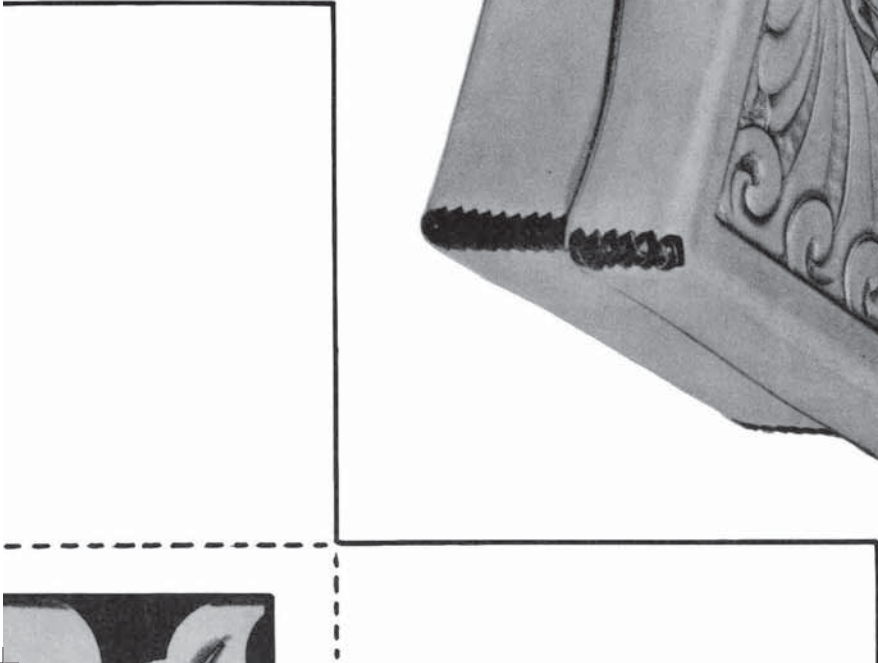
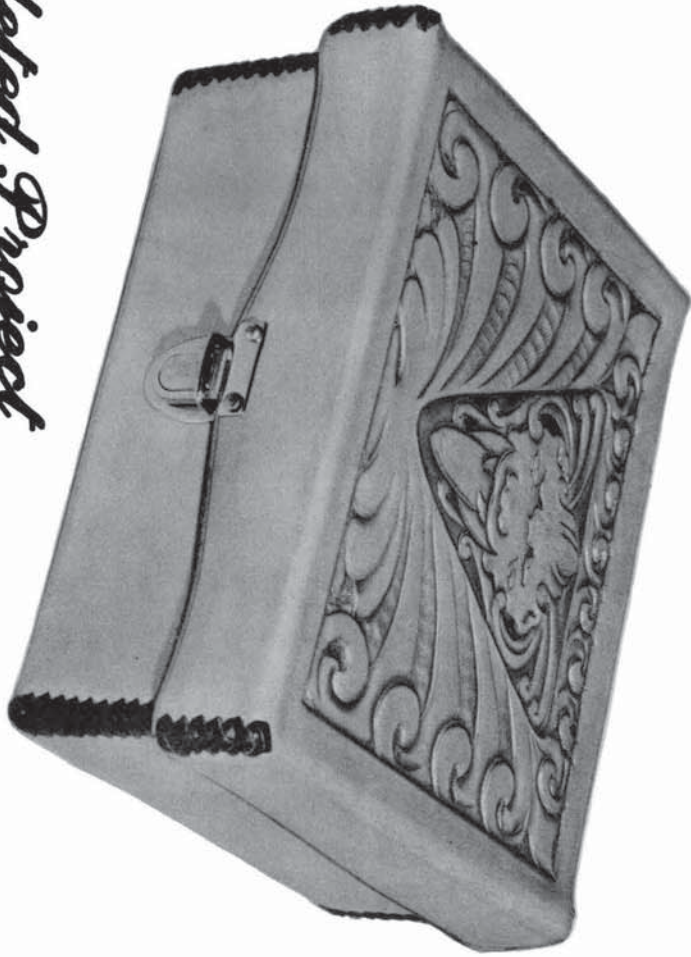





Alternate Design



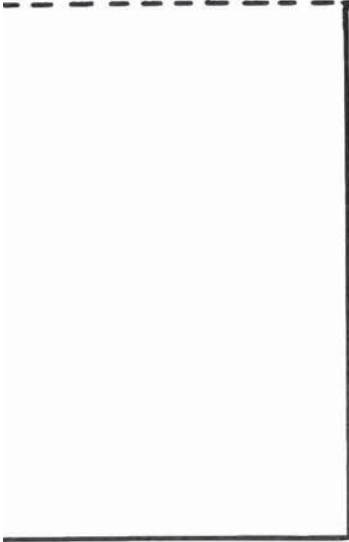
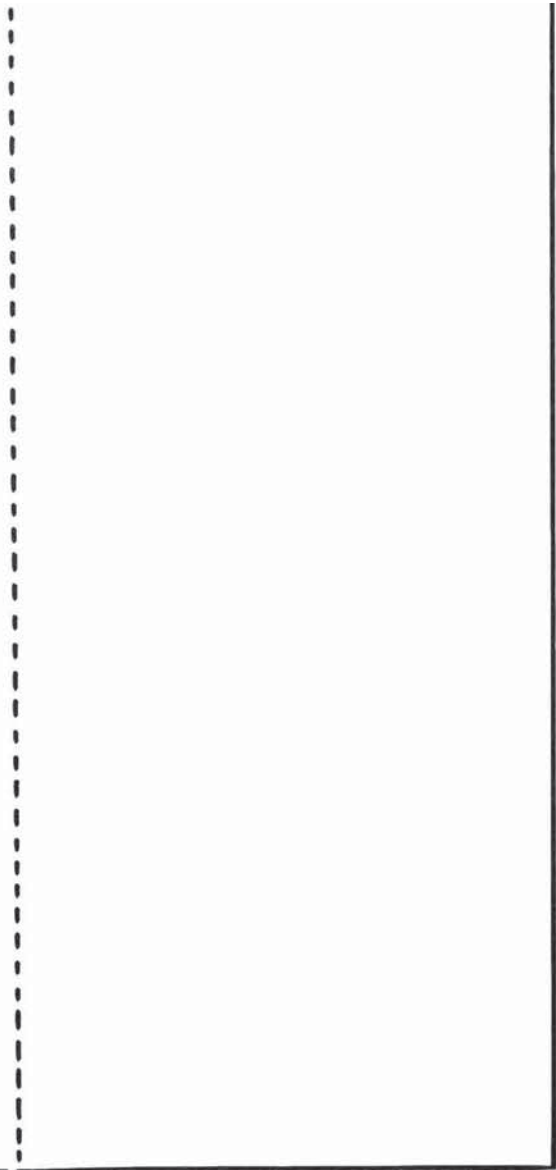

Town & Country

PROCEDURE

1. Make tracing and cutting patterns.
2. Cut project from leather, 4-5 oz. strap leather or heavy tooling calf.
3. Moisten leather with sponges, allowing moisture to penetrate, then let surface dry until it has ALMOST turned to the original color.
4. Transfer tracing design to cased leather, using 4H drawing pencil or stylus.
5. Carve and stamp design, (see procedure).
6. Use woolskin pad to polish grain sides of the project. Polish each piece IMMEDIATELY after carving is finished.
7. Skive all outside edges that are to be laced.

ONE - HALF
OF
GUSSET PATTERN

CENTER

ASSEMBLY INSTRUCTIONS

STEP-1

1. Cut out linings. NOTE: linings should be cut approximately 1/8" larger, then skived before rubber cementing to outer leathers.
2. Line and lace handle "B".

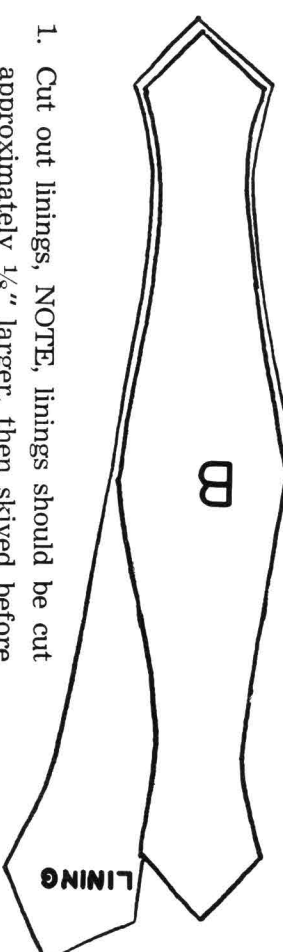

STEP-2

3. Secure handle "B" to piece "A", FIRST sew under loop then secure Loop "E", by rubber cementing ends on back of piece "A", (see illustrations). Dye and crease edges of loops, or make turned loops. The loops may also be edge laced or diamond laced through center.

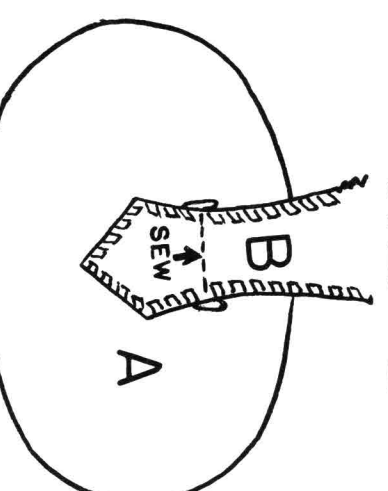

STEP-3

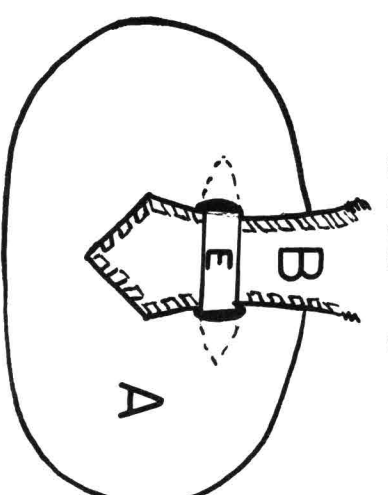

STEP-4

- Above illustrations shows handle assembly completed.

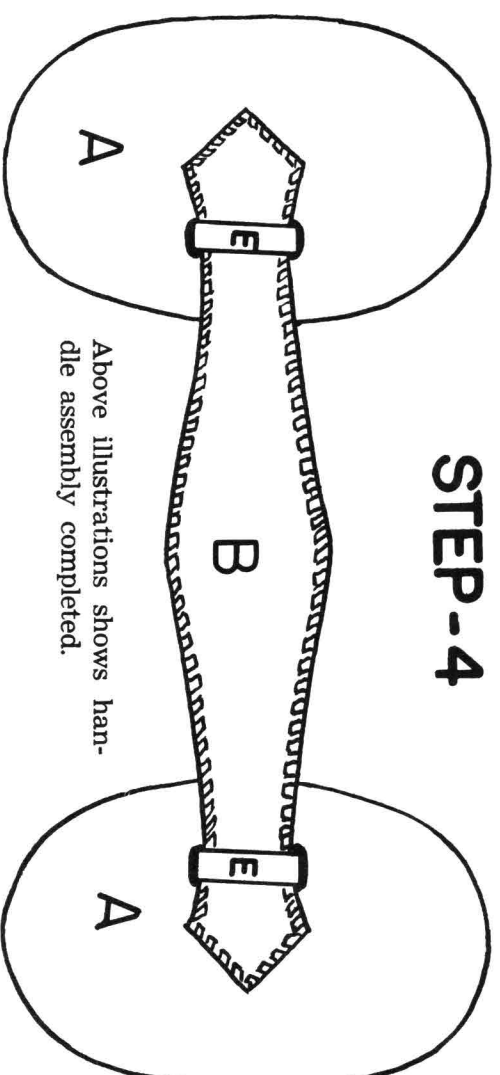

STEP-5

1. Sew or lace pocket "D" to lining "A", then cement liners to pieces "A".

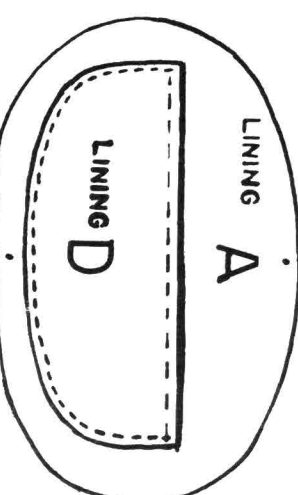

FINISHED BAG



STEP-6

STEP-6

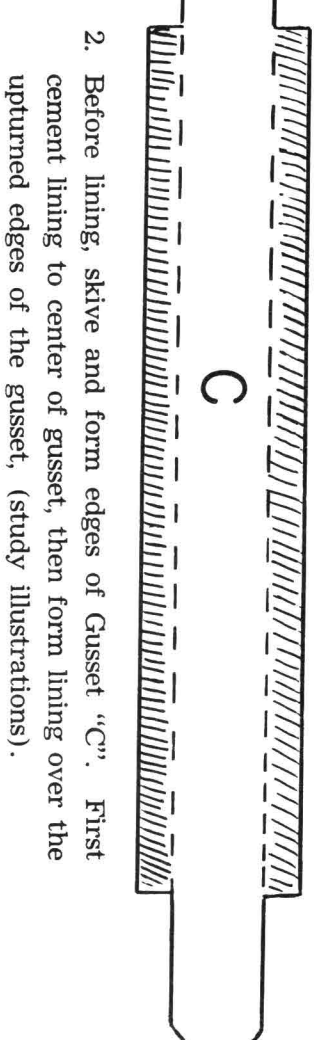

2. Before lining, skive and form edges of Gusset "C". First cement lining to center of gusset, then form lining over the upturned edges of the gusset, (study illustrations).

STEP-8

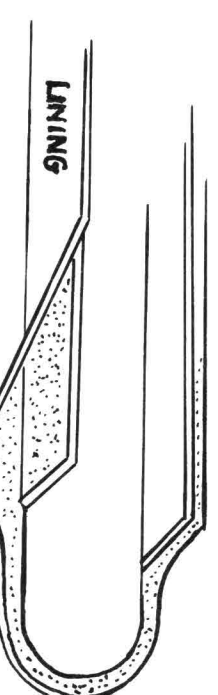

CARVING PROCEDURE

1. Swivel cut border lines, then flowers, leaves, stems, in this order.
2. Use large beveler No. 195 to bevel border lines. BEVEL TO INSIDE, which will raise the border as a protection from the stamp tools.
3. Pear-shading.
4. Barker tool on whirls.
5. Backgrounding.
6. Beveling, first use large beveler on all long straight cuts, next medium beveler.
7. Camouflage on all main stems.
8. Veining.
9. Use swivel knife to ornamental cut design, study photo, this is a very important step and practice is essential.
10. Use Mules Foot on acanthus and stems.
11. Stamp seed pod.
12. Use large or medium beveler to bevel down all parts of the design touching the border, being careful not to touch background with the beveling tool.

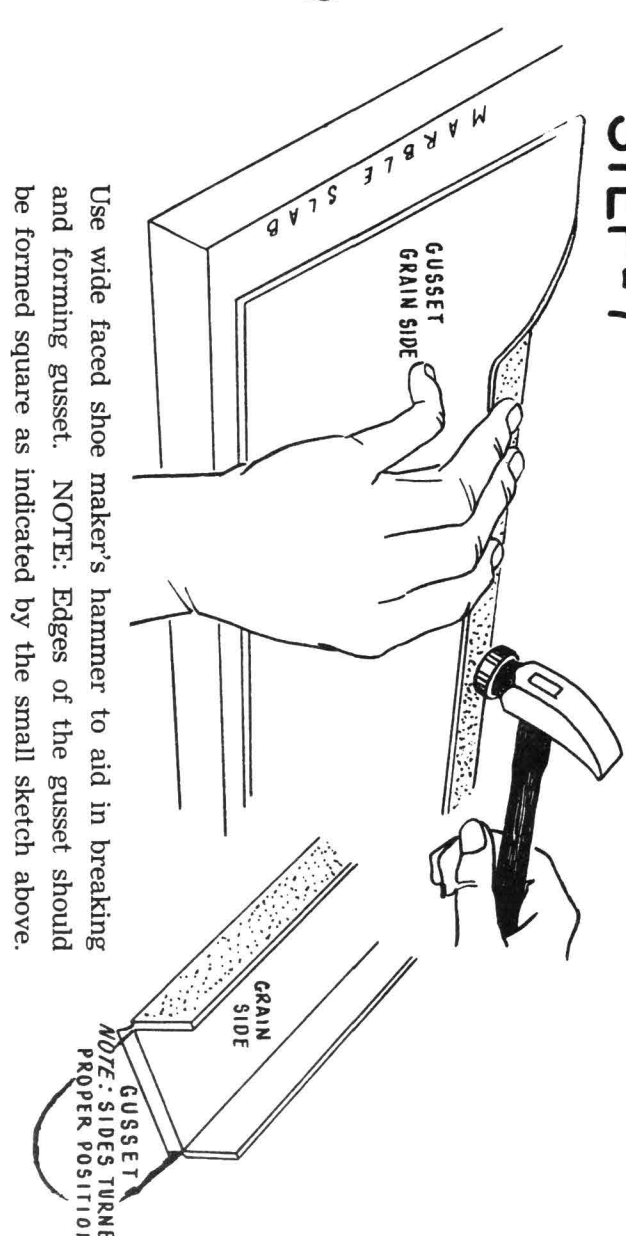

STEP-7

- Use wide faced shoe maker's hammer to aid in breaking and forming gusset. NOTE: Edges of the gusset should be formed square as indicated by the small sketch above.

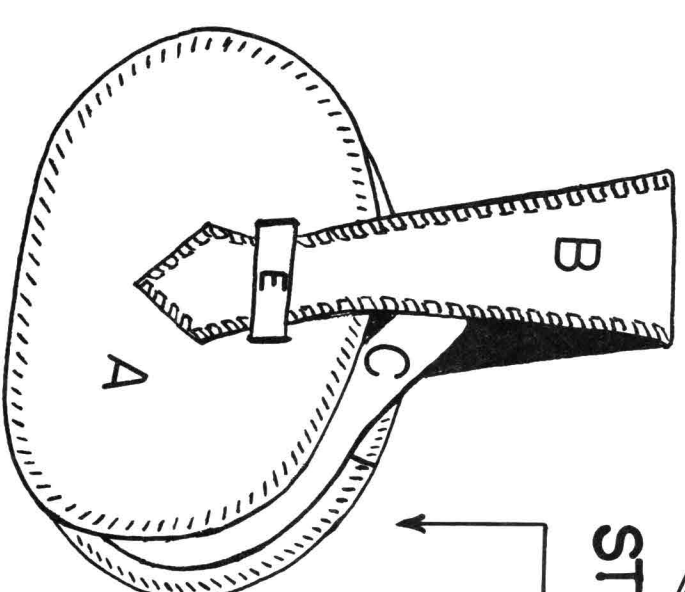

STEP-9

1. Assemble purse by cement edges of each section piece "A", "B" and "C" together, start at bottom center and work both ways.
2. Punch and lace.
3. Attach lock, use Snap Lock No. 858 or Snap the PERSH Lock No. 858. Use on this purse. Use tab "F" if Snap-Tab pattern is used or make turn lock of your choice.

POCKET PATTERN

D

SKIVE FLESH SIDE INDICATED BY DOTTED LINES, THEN PLACE LINER UP TO DOTTED LINES, FOLD SHADED AREA OVER LINING, SEW OR LACE ACROSS TOP.

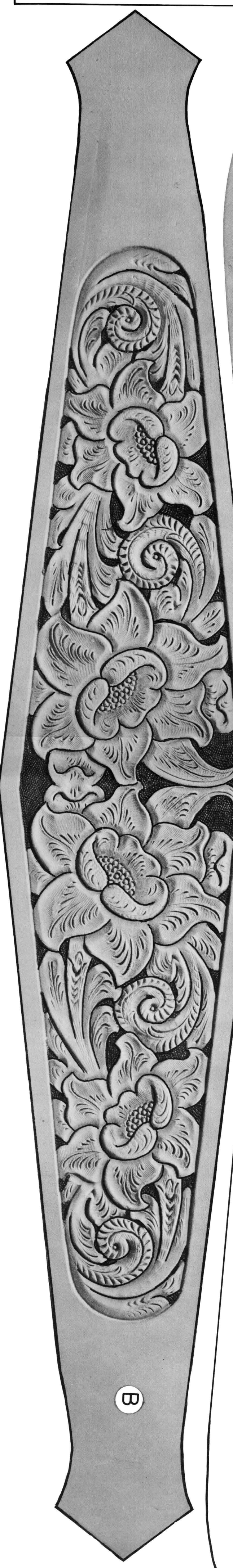

TAB

ONE - HALF
OF
GUSSET PATTERN

CENTER

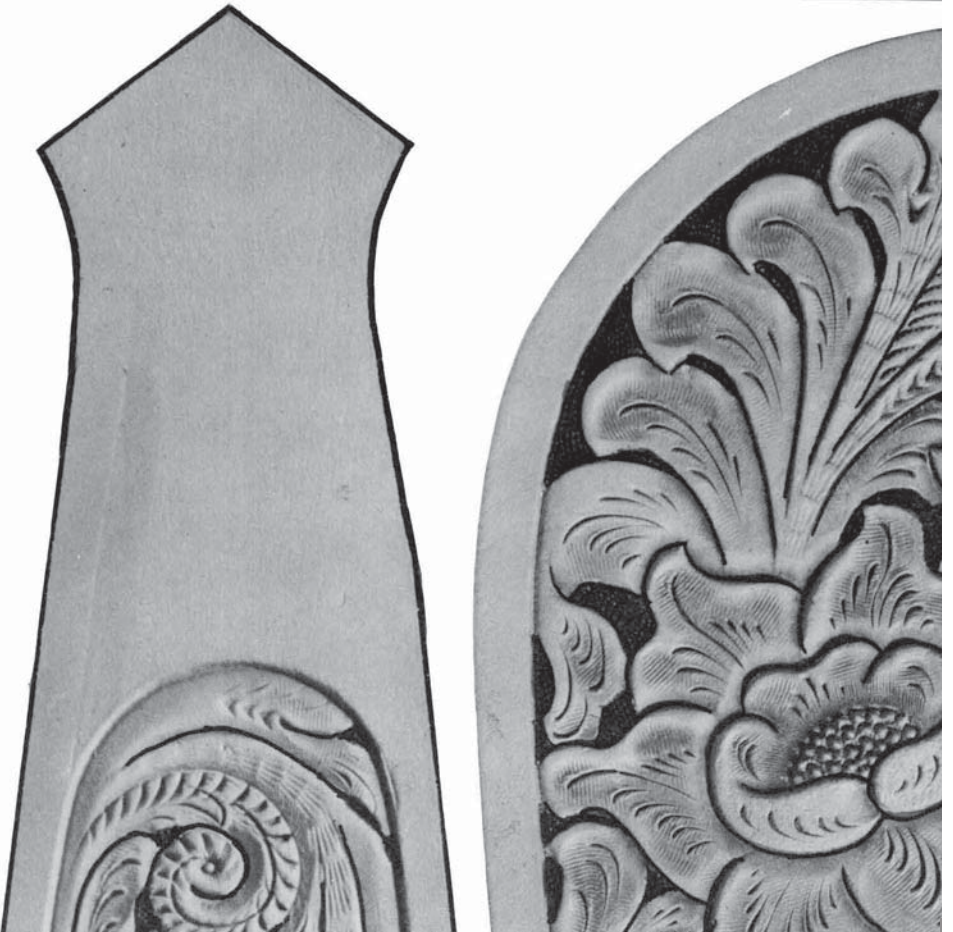

C



Town & Country

PROCEDURE

1. Make tracing and cutting patterns.
2. Cut project from leather, 4-5 oz. strap leather or heavy tooling calf.
3. Moisten leather with sponge, allowing moisture to penetrate, then let surface dry until it has **ALMOST** turned to the original color.
4. Transfer tracing design to cased leather, using 4H drawing pencil or stylus.
5. Carve and stamp design, (see procedure).
6. Use woolskin pad to polish grain sides of the project. Polish each piece **IMMEDIATELY** after carving is finished.
7. Skive all outside edges that are to be laced.

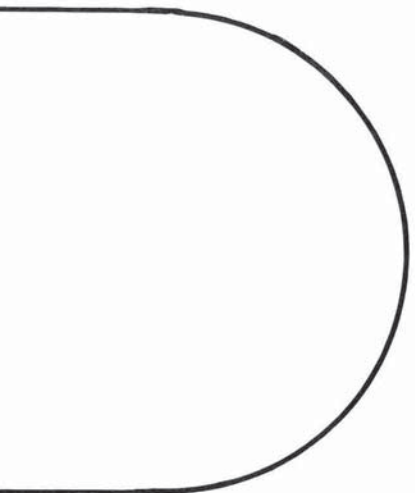

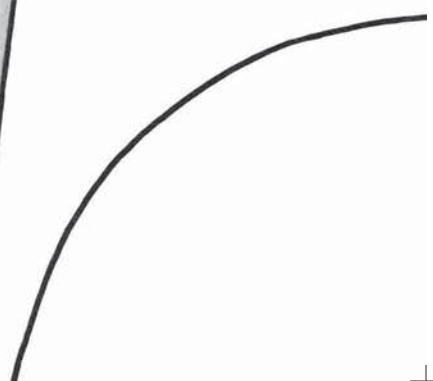
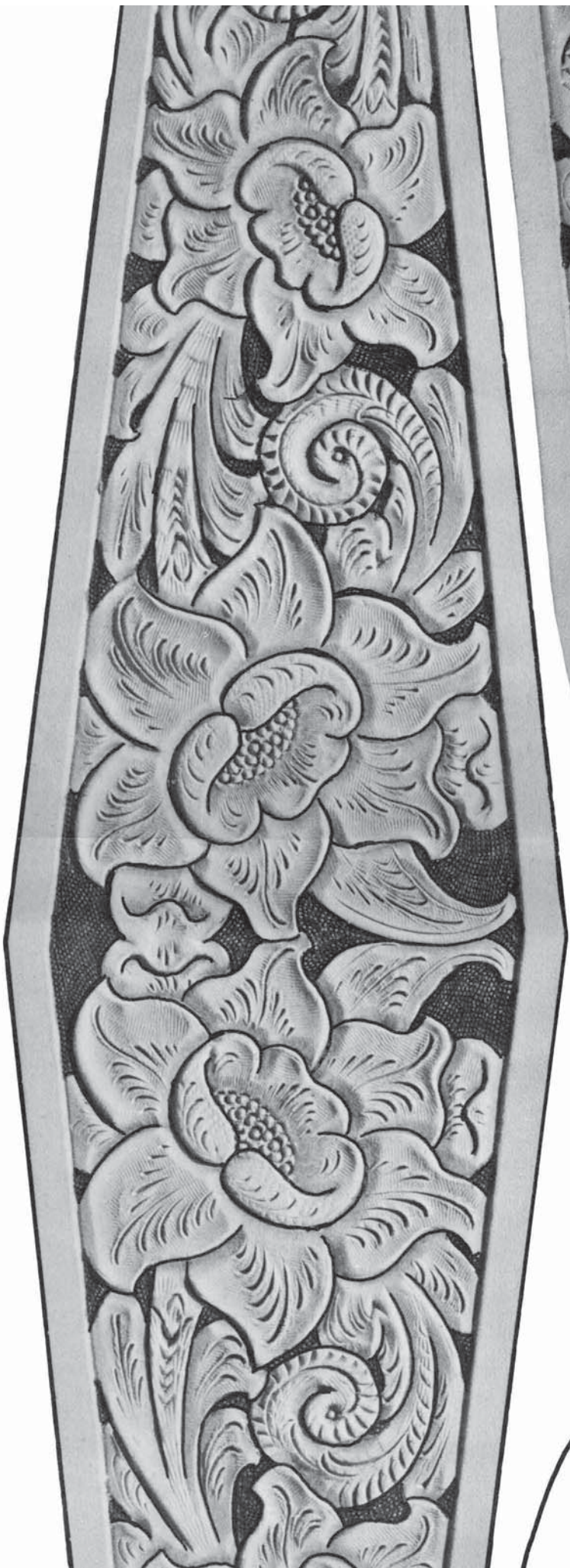

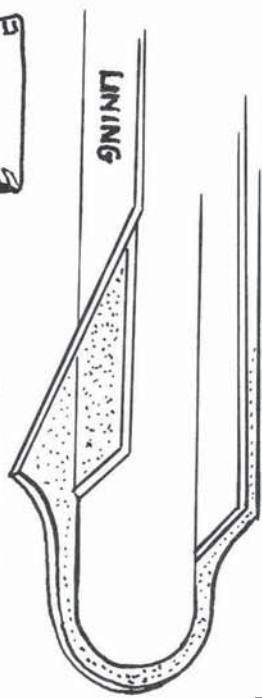
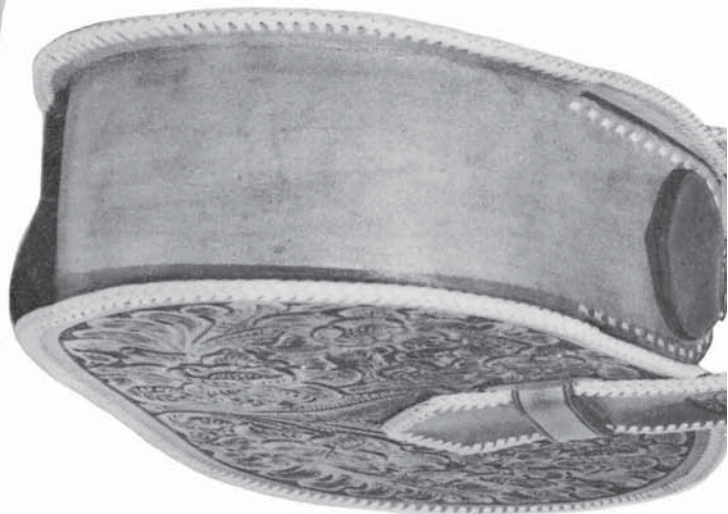

STEP-9

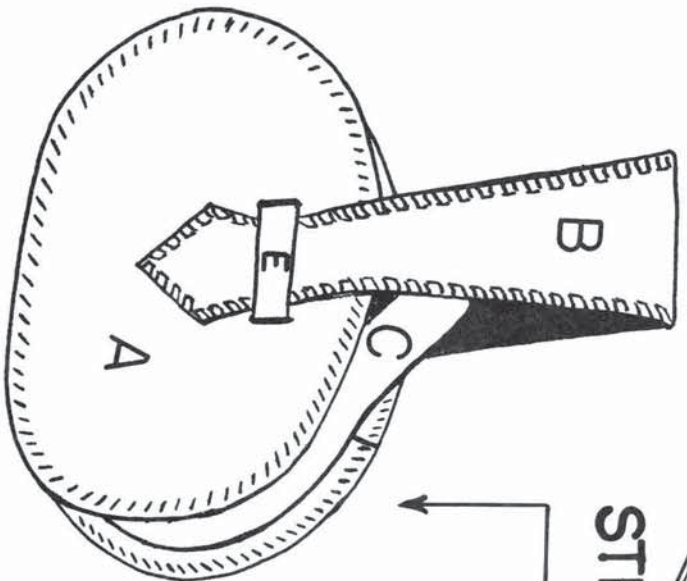

1. Assemble purse by cement edges of each section "A" and "C" together, start at bottom center in both ways.

2. Punch and lace.

3. Attach lock, use small Turn Lock or Snap-tite, PRESTO Lock No. 858 was used on this purse. Use tab "F" if Snap-tite is used or make tab pattern to fit the turn lock of your choice.



ASSEMBLY INSTRUCTIONS

STEP-1

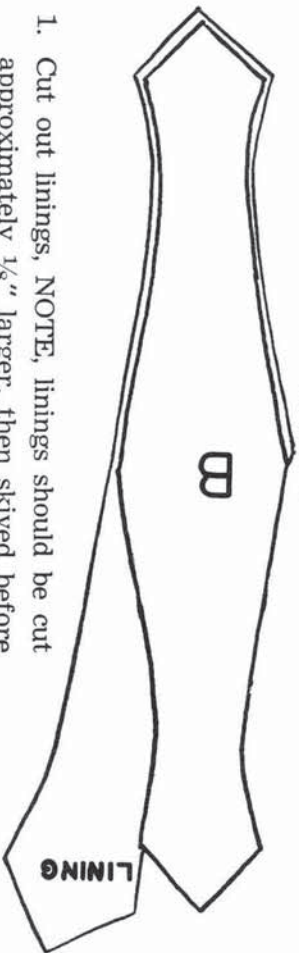

1. Cut out linings, NOTE, linings should be cut approximately 1/8" larger, then skived before rubber cementing to outer leathers.
2. Line and lace handle "B".

STEP-2

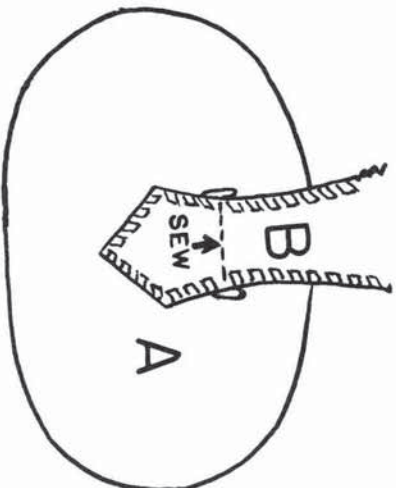

STEP-3

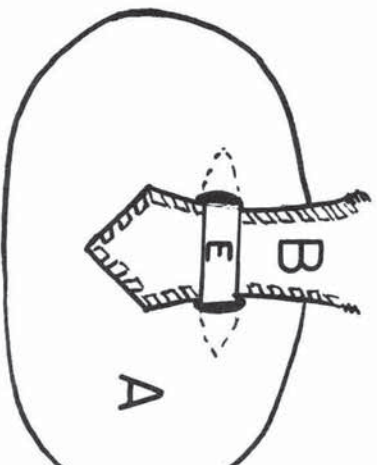

3. Secure handle "B" to piece "A", FIRST sew under loop then secure Loop "E", by rubber cementing ends on back of piece "A", (see illustrations). Dye and crease edges of loops, or make turned loops. The loops may also be edge laced or diamond laced through center.

FINISHED BAG



STEP-6

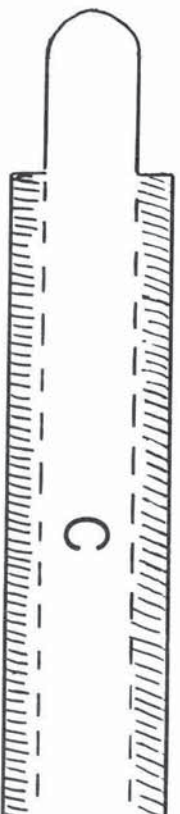

STEP-8

2. Before lining, skive and form edges of Guss cement lining to center of gusset, then form upturned edges of the gusset, (study illustra

POCKET PATTERN

D

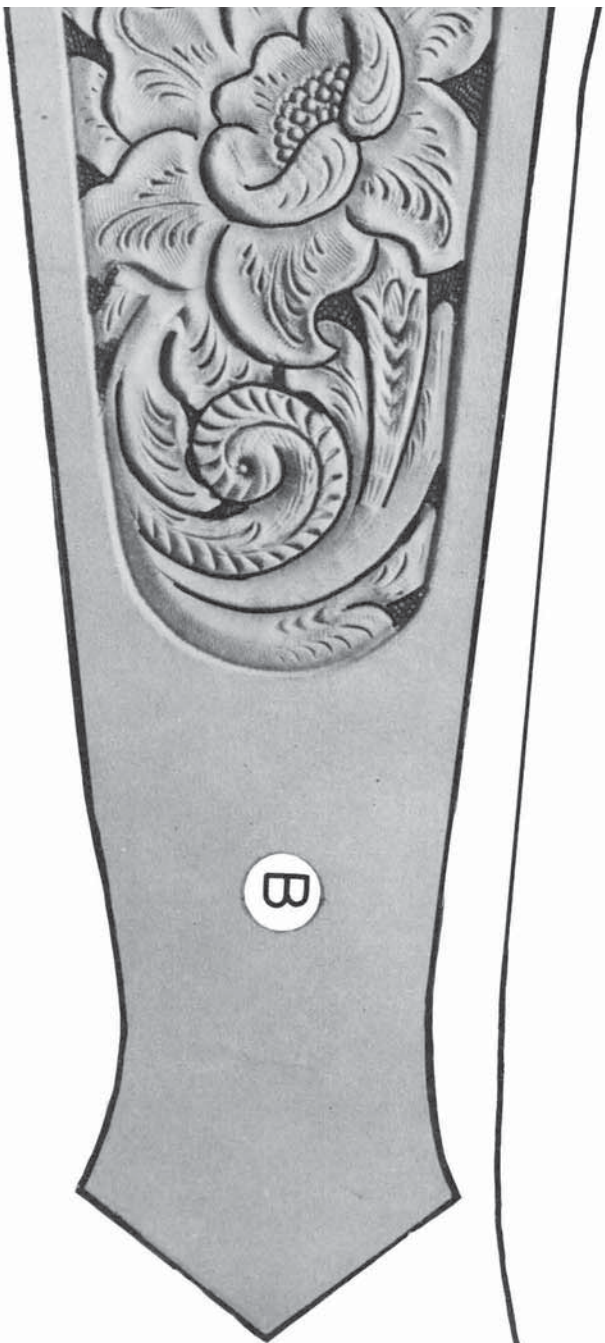

B

F

TAB

CARVING PROCEDURE

1. Swivel cut border lines, then flowers, leaves, stems, in this order.
2. Use large beveler No. 195 to bevel border lines, BEVEL TO INSIDE, which will raise the border as a protection from the stamp tools.
3. Pear-shading.
4. Barker tool on whirls.
5. Backrounding.
6. Beveling, first use large beveler on all long straight cuts, next medium beveler.
7. Camouflager on all main stems.
8. Veining.
9. Use swivel knife to ornamental cut design, study photo, this is a very important step and practice is essential.
10. Use Mules Foot on acanthus and stems.
11. Stamp seed pod.
12. Use large or medium beveler to rebevel down all parts of the design touching the border, being careful not to touch background with the beveling tool.

SKIVE FLESH SIDE INDICATED BY DOTTED LINES, THEN PLACE LINER UP TO DOTTED LINES, FOLD SHADED AREA OVER LINING, SEW OR LACE ACROSS TOP.



on piece
and work

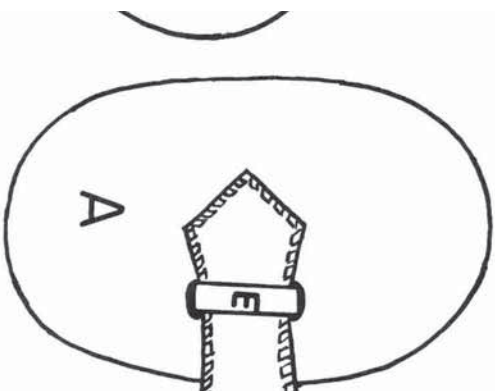

STEP-4

Above illustrations shows hand-die assembly completed.

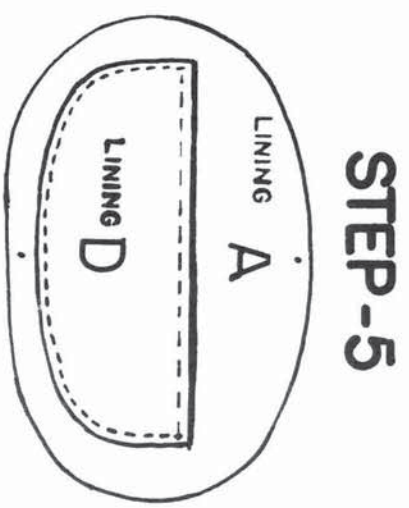
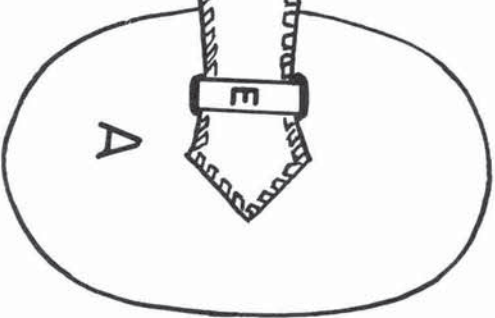

STEP-5

1. Sew or lace pocket "D" to lining "A", then cement liners to pieces "A".

STEP-7

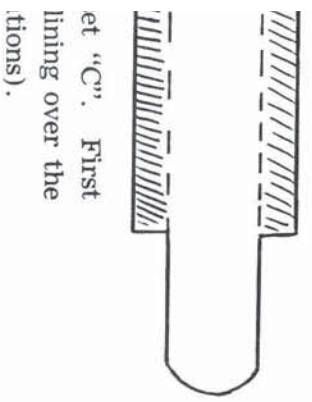

et "C". First lining over the (tions).

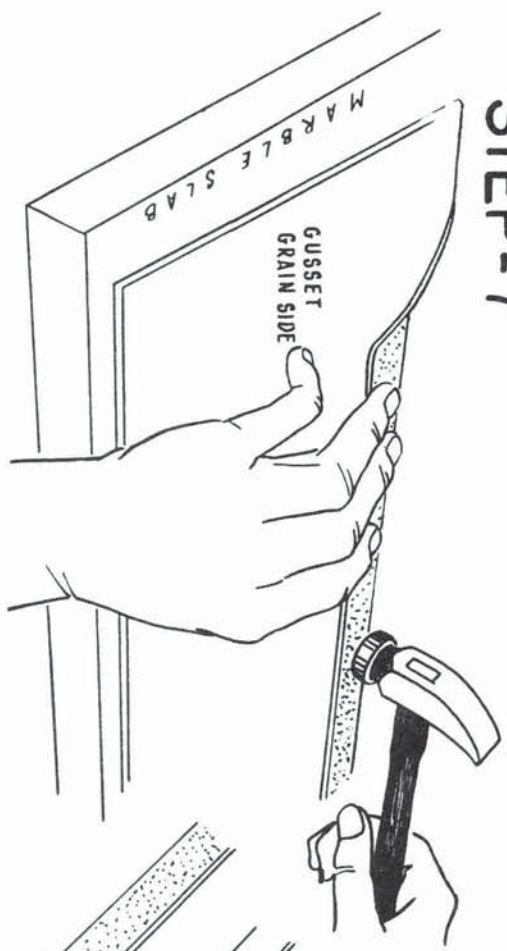

Use wide faced shoe maker's hammer to aid in breaking and forming gusset. NOTE: Edges of the gusset should be formed square as indicated by the small sketch above.

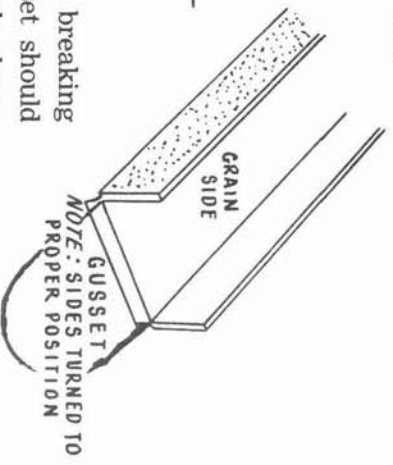

NOTE: SIDES TURNED TO PROPER POSITION