

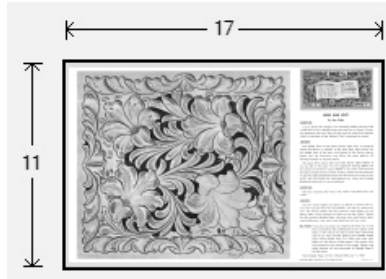

Doodle Page Digital Download

This PDF file contains 1 (one) Doodle Page. The PDF has been put together to give you options when it comes to printing. Pages and patterns that are larger than 8½x11 have been provided in two formats:



1) Full Size

If you would like to have a full size print out, take the full size pages to your local print shop and they can print it for you. All full size Doodle Pages are 11x17



2) Tiled

The tiled pages give you the option of printing the full sized Doodle Pages at home. You print the tiled pages and then assemble them to make the larger patterns.

The Doodle Page PDF files are typically laid out like this:

Front – full sized, front – tiled, back – full sized, back – tiled

(Some Doodle Pages do not have backs)

Please note: When printing on a home printer, the edges may get cut off. To avoid this, make sure “Page Scaling” is set to “Shrink to Printable Area” in the Adobe Reader print dialogue box. This will decrease the size of the Doodle Page a very small amount.

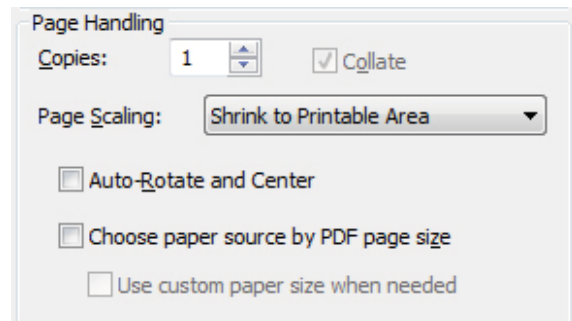

You may take this PDF file to your local print shop to have the full-size pages printed for your own personal use.

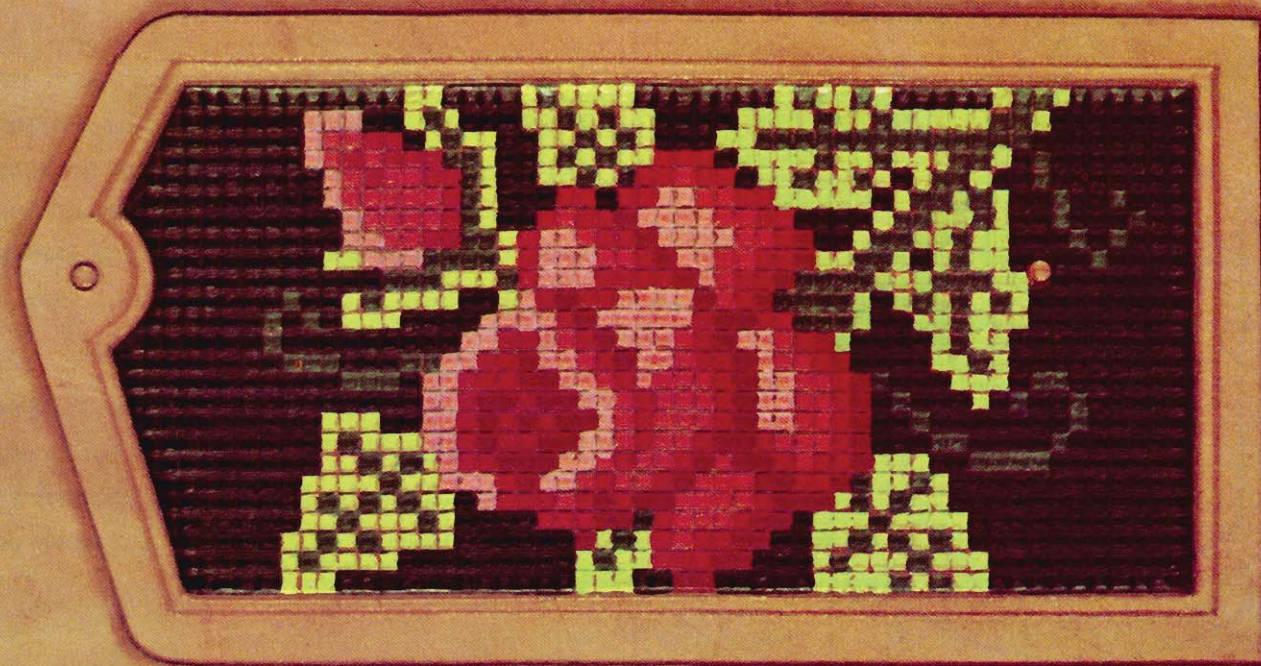

KEY CASE Design

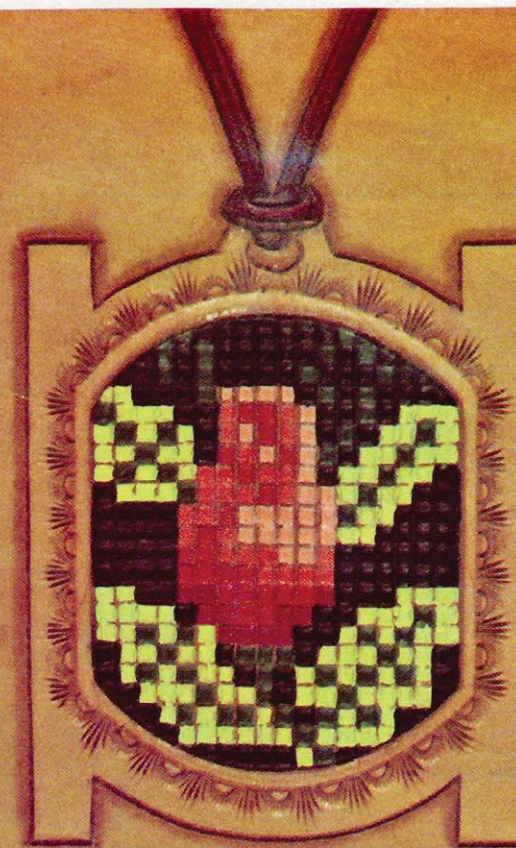

MEDALLION Design

Photo-Carve Pattern

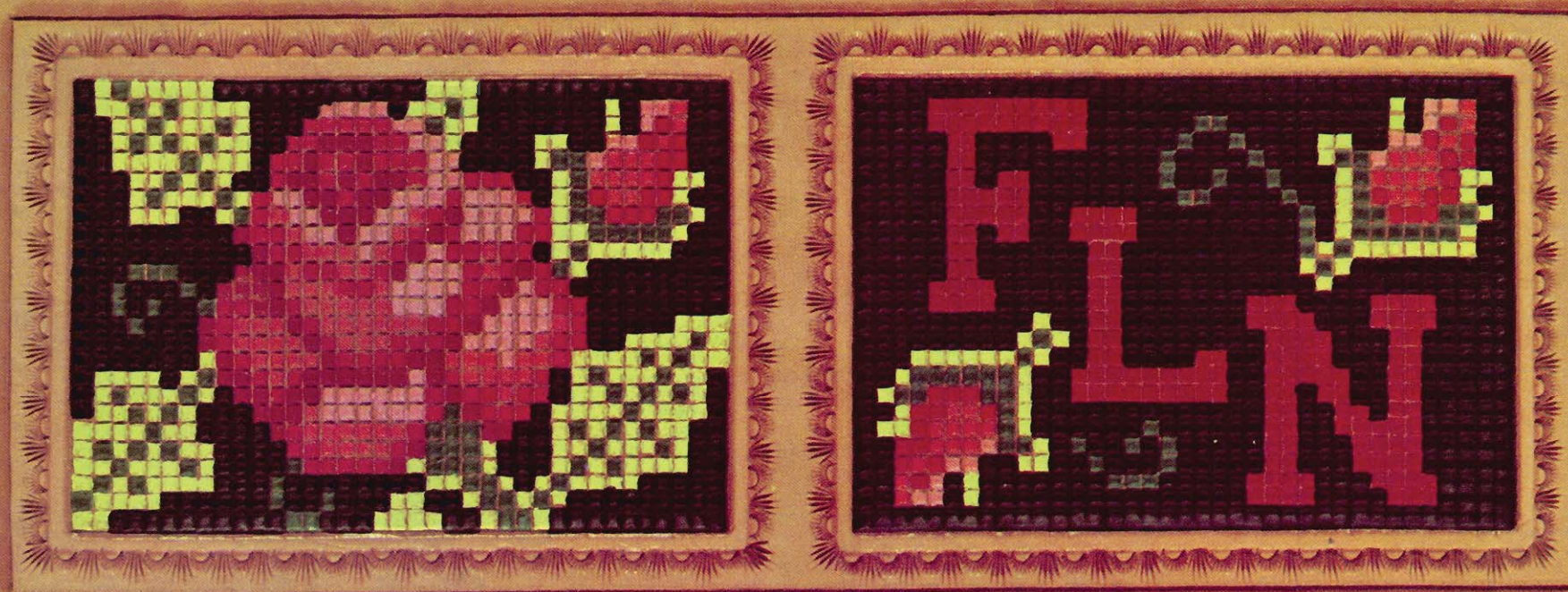

BILLFOLD Design

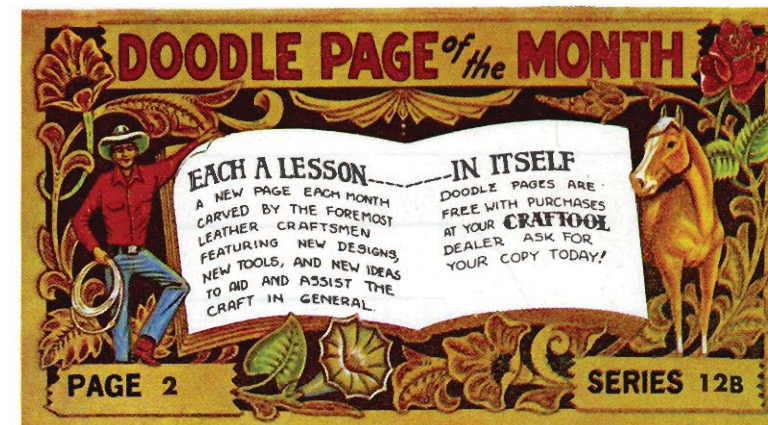

"Leather" NEEDLE-POINT

By GENE NOLAND

Since Needle-Point is becoming quite a craft around the country, I thought it might look nice on leather work. Like maybe on a Billfold, Key case, Medallion or even a handbag design if someone could come up with a nice pattern.

I tried to pick a pattern that would be easy to do and one that would attract women as I believe they enjoy Needle-Point more than men. However I think a man might make one for his wife, daughter or a girl friend if he isn't married.

This design can be worked into Indian Beadwork if one would rather have the western touch.

To do these patterns, trace the design on the leather but only indicate the check lines along the inside edge of the panel. Then cut them with a straight-edge to form your squares. Next do your beveling around the inside of the panels. Now you can either leave them plain as I have done on the Key case or put a border on them as shown on the Billfold and Medallion designs. This was done by alternating tools No. F916 with No. C770 or any other tool you wish to make a border with. However I do feel the border sets off the panel and really completes the design.

(Continued on reverse side)

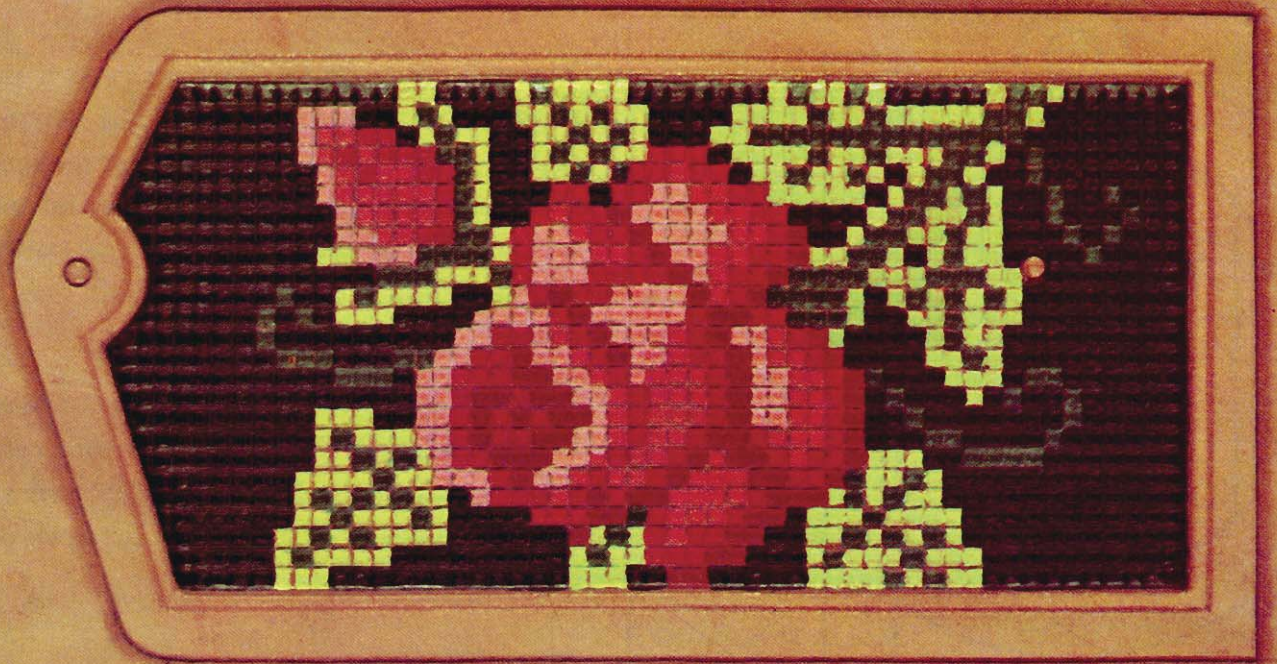

KEY CASE Design

Photo-Carve Pattern

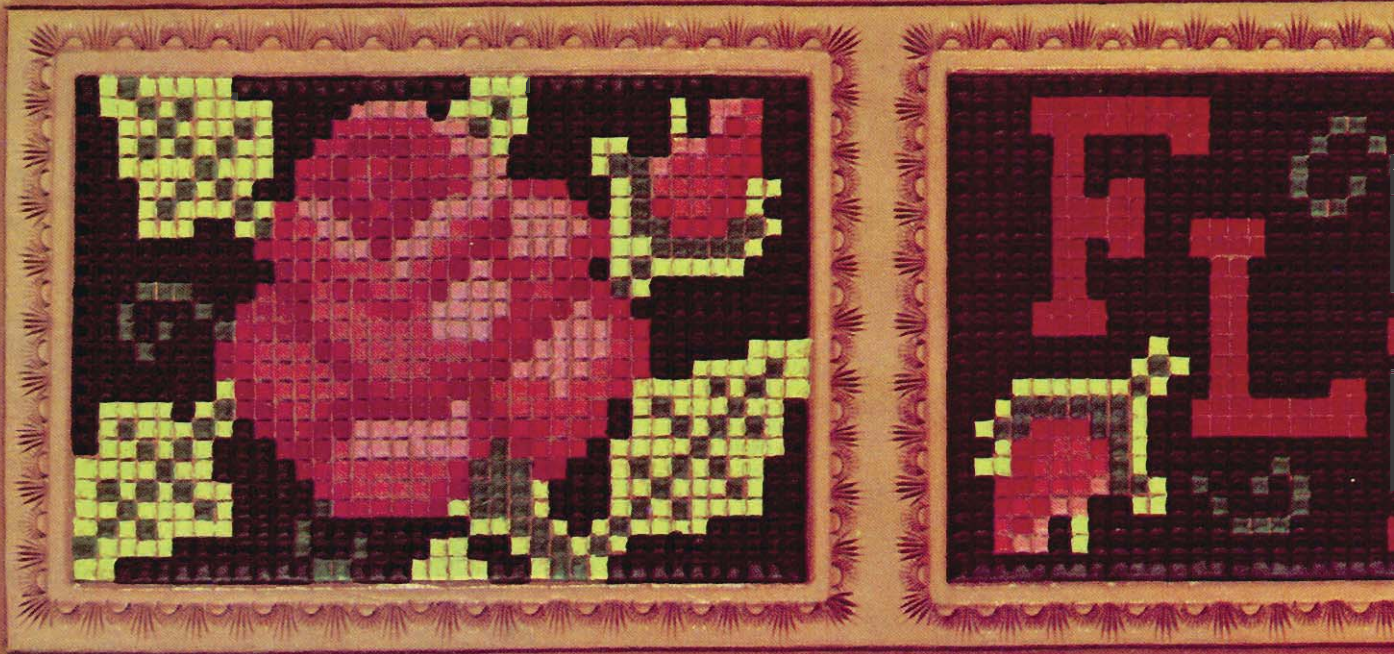

BILLFOLD Design

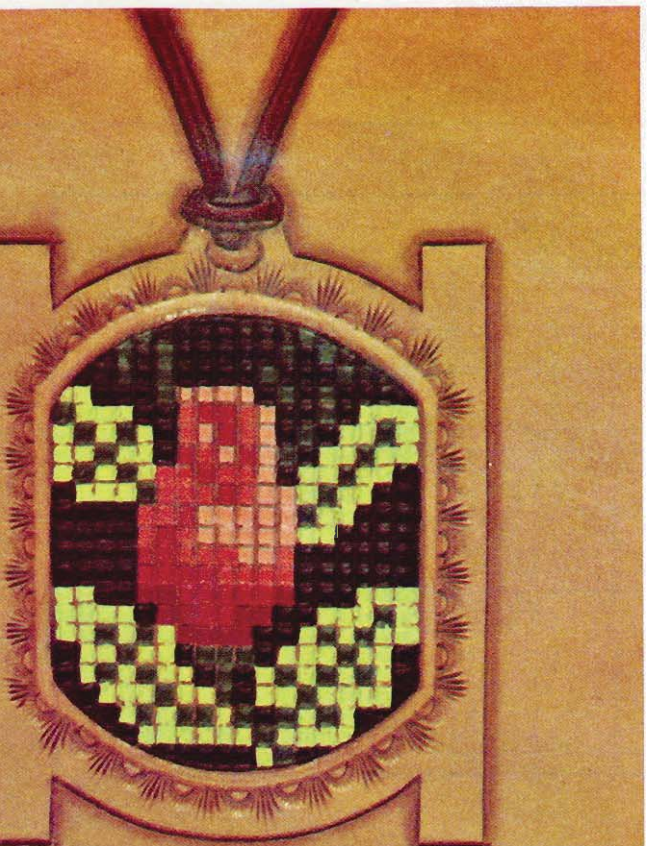

MEDALLION Design

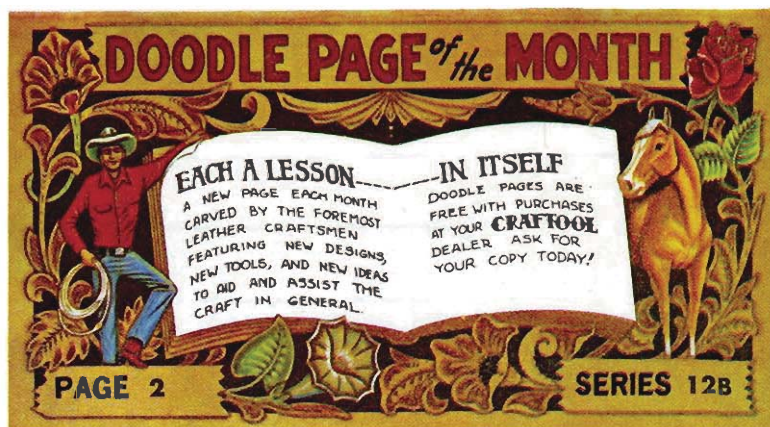

"Leather" NEEDLE-POINT

By GENE NOLAND

Since Needle-Point is becoming quite a craft around the country, I thought it might look nice on leather work. Like maybe on a Billfold, Key case, Medallion or even a handbag design if someone could come up with a nice pattern.

I tried to pick a pattern that would be easy to do and one that would attract women as I believe they enjoy Needle-Point more than men. However I think a man might make one for his wife, daughter or a girl friend if he isn't married.

This design can be worked into Indian Beadwork if one would rather have the western touch.

To do these patterns, trace the design on the leather but only indicate the check lines along the inside edge of the panel. Then cut them with a straight-edge to form your squares. Next do your beveling around the inside of the panels. Now you can either leave them plain as I have done on the Key case or put a border on them as shown on the Billfold and Medallion designs. This was done by alternating tools No. F916 with No. C770 or any other tool you wish to make a border with. However I do feel the border sets off the panel and really completes the design.

(Continued on reverse side)

When your beveling and border is done, use the tip of your modeling tool, not the spoon end, to go over the cut lines that form the squares until each stands out by itself.

You will notice on the Tracing Pattern that there is no design other than the squares. The design is formed by applying color to the squares. Count the squares and color them as you go, leaving the background until last. However, each little square should stand out by itself. This will also allow you to make up your own design if you choose.

I colored these with Designers Opaque Water colors but I suggest you use Cova-Dyes. Mix your colors as close to those shown in the Photo-Carve Pattern and I am sure you will come out with a design as shown on this Doodle Page.

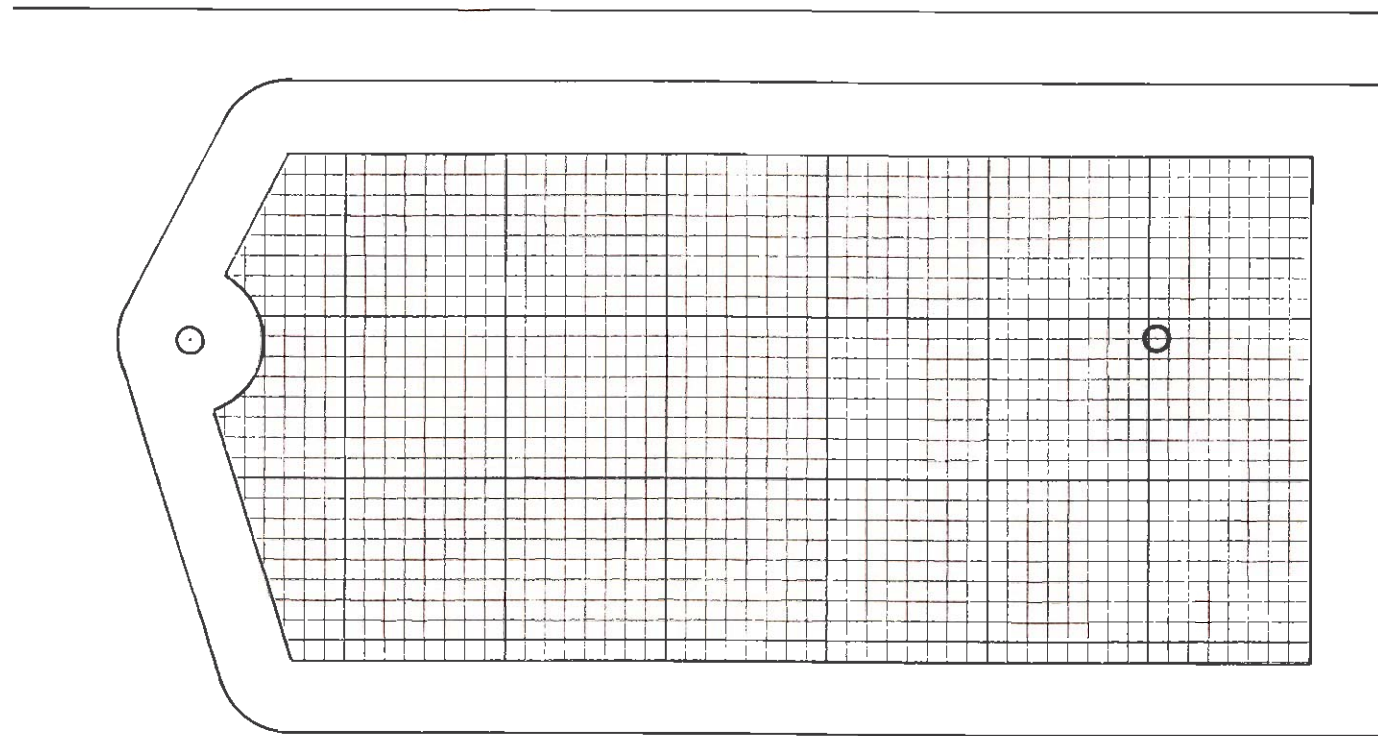

KEY CASE Design

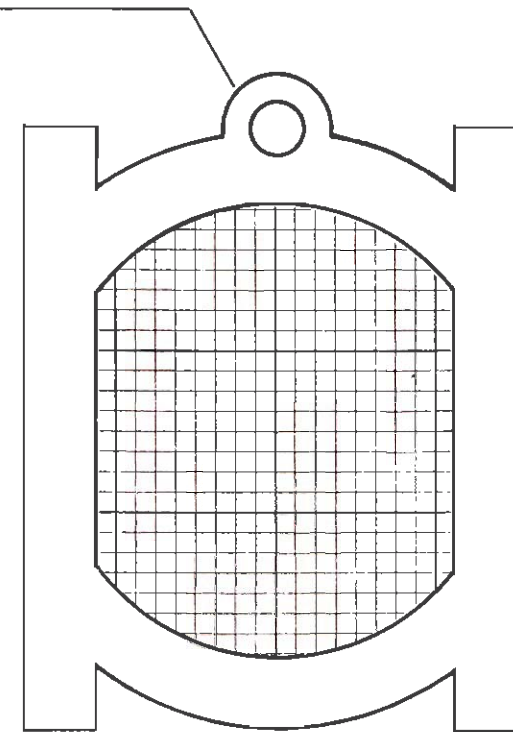

MEDALLION Design

Tracing Pattern

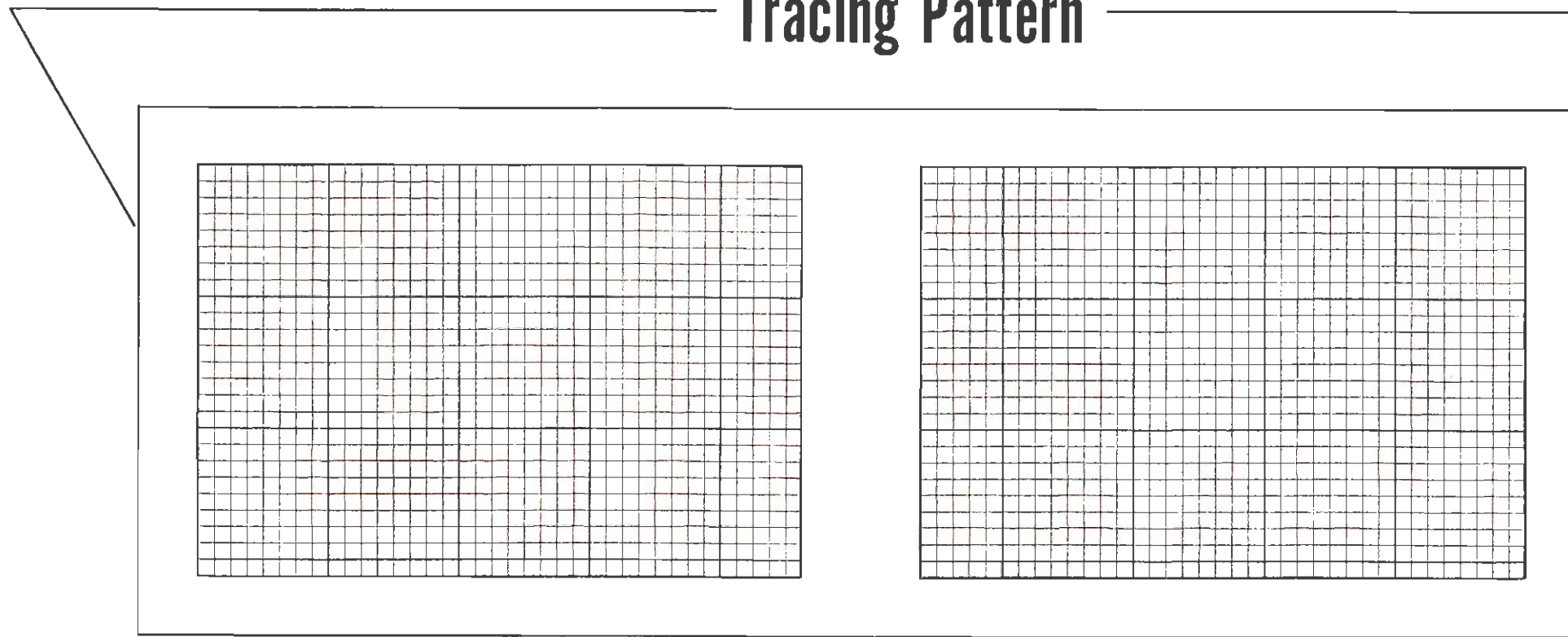

BILLFOLD Design



LUCKY 7 TEXT BOOK
Written for the home craftsman. Also for classroom. Fully illustrated. Wallet designs by 7 professional western craftsmen.\$1.50



FIGURE CARVING
Featuring a NEW METHOD of instruction. Dozens of Figures and Dye-Charts. Covers are printed in full color.\$2.00



Ken Griffin's SCRAP BOOK
A jumbo size book of new designs and patterns. Pages 18" x 15" with full size tracings and Foto-Carve patterns. Leather carving made easy.\$3.50

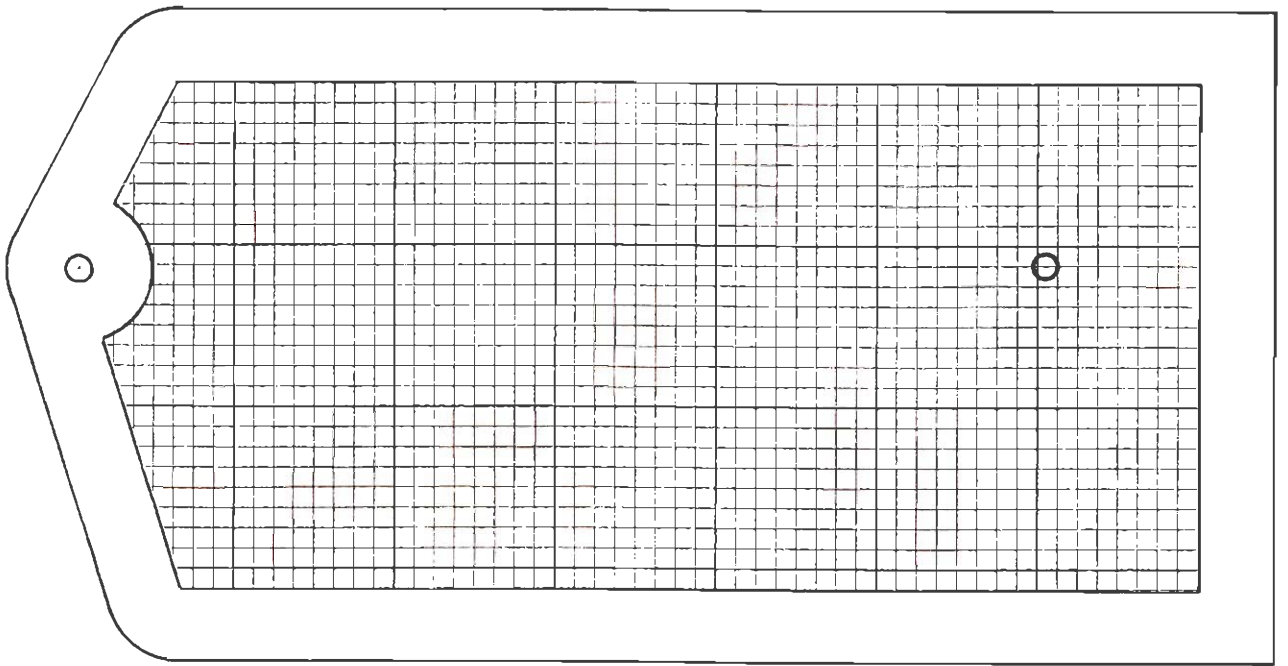

KEY CASE Design

Tracing Pattern

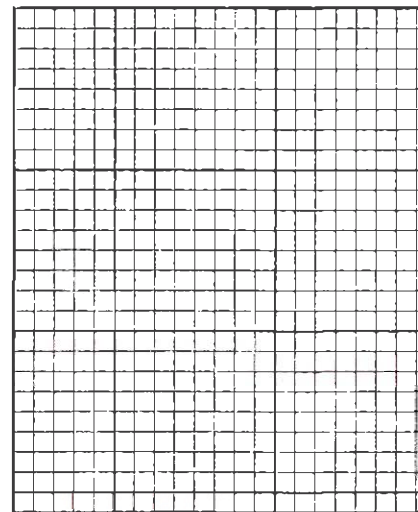
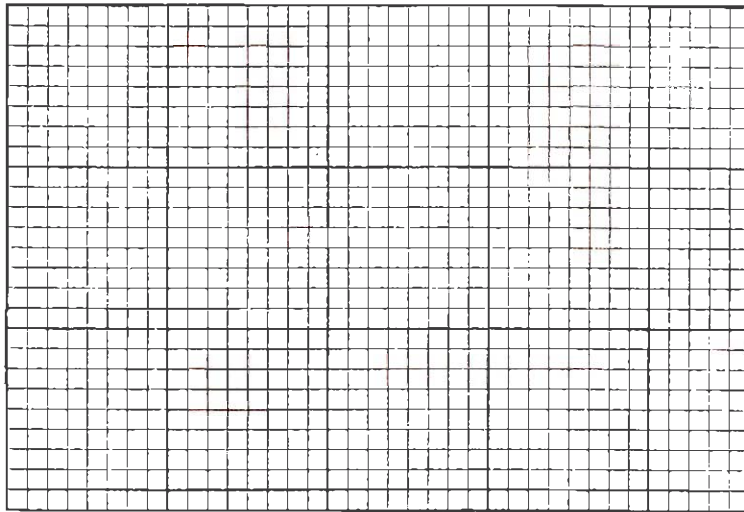

BILLFOLD Design

LEATHER NEEDLE-POINT — Continued

When your beveling and border is done, use the tip of your modeling tool, not the spoon end, to go over the cut lines that form the squares until each stands out by itself.

You will notice on the Tracing Pattern that there is no design other than the squares. The design is formed by applying color to the squares. Count the squares and color them as you go, leaving the background until last. However, each little square should stand out by itself. This will also allow you to make up your own design if you choose.

I colored these with Designers Opaque Water colors but I suggest you use Cova-Dyes. Mix your colors as close to those shown in the Photo-Carve Pattern and I am sure you will come out with a design as shown on this Doodle Page.

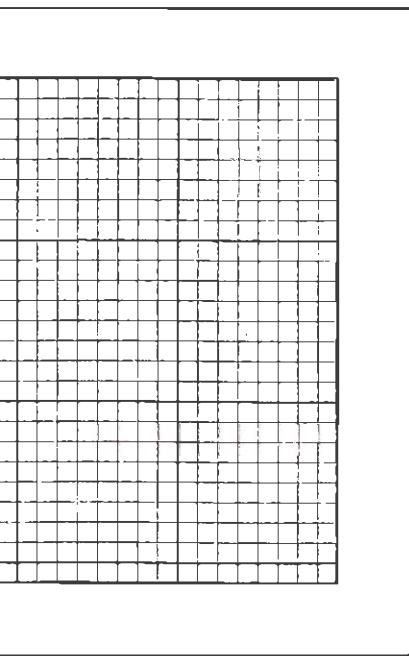
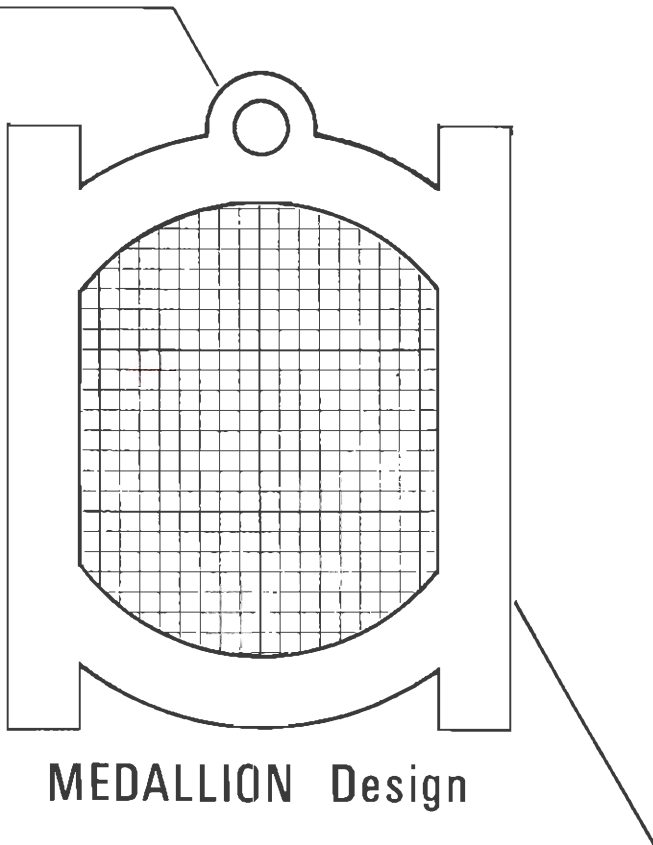

LUCKY 7 TEXT BOOK
Written for the home craftsman. Also for classroom. Fully illustrated. Wallet designs by 7 professional western craftsmen.\$1.50



FIGURE CARVING
Featuring a NEW METHOD of instruction. Dozens of Figures and Dye-Charts. Covers are printed in full color.\$2.00



Ken Griffin's SCRAP BOOK
A jumbo size book of new designs and patterns. Pages 18" x 15" with full size tracings and Foto-Carve patterns. Leather carving made easy.\$3.50