



Doodle Page Digital Download

This PDF file contains 1 (one) Doodle Page. The PDF has been put together to give you options when it comes to printing. Pages and patterns that are larger than 8½x11 have been provided in two formats:



1) Full Size

If you would like to have a full size print out, take the full size pages to your local print shop and they can print it for you. All full size Doodle Pages are 11x17



2) Tiled

The tiled pages give you the option of printing the full sized Doodle Pages at home. You print the tiled pages and then assemble them to make the larger patterns.

The Doodle Page PDF files are typically laid out like this:

Front – full sized, front – tiled, back – full sized, back – tiled

(Some Doodle Pages do not have backs)

Please note: When printing on a home printer, the edges may get cut off. To avoid this, make sure “Page Scaling” is set to “Shrink to Printable Area” in the Adobe Reader print dialogue box. This will decrease the size of the Doodle Page a very small amount.



You may take this PDF file to your local print shop to have the full-size pages printed for your own personal use.

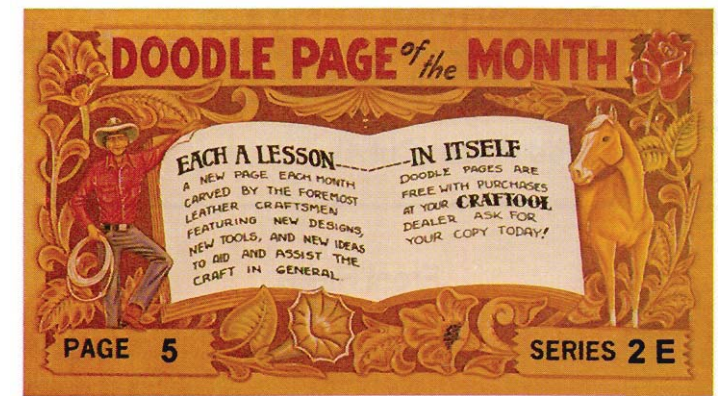

CARD HOLDER

by Tim Grothen

My wife, and I, have friends who are in the cottage industry profession on an almost full time basis. That is, they build things in their home, and distribute them to area craft stores, and area craft fairs. Business cards are an important part of their business, since it is almost their only method of advertising. Recently, they asked me if I could design some kind of card holder that would catch people's eyes. Since it was a heavy production period for them, they did not have the time to think about making something on their own. Nearly everything was left up to me, except for the wish that it would have something to do with a cottage, and would go along with their cottage industry.

This is an easy project, with fairly simple carving, but be aware that there is a bit of construction that will be necessary. It is made of 10 pieces. The tracing pattern has all the pieces on it, but some had to be overlapped, in order to fit within the area.

Many things can be changed to suit your own needs, such as the wording on the red roof. The original project had SHA-RON on it, since it is our friends business name. There are many good letter patterns in the book "ALPHABETS FOR THE LEATHERCRAFTER, #1936." You can be creative by maybe changing the heart to something more detailed, to show off your carving.

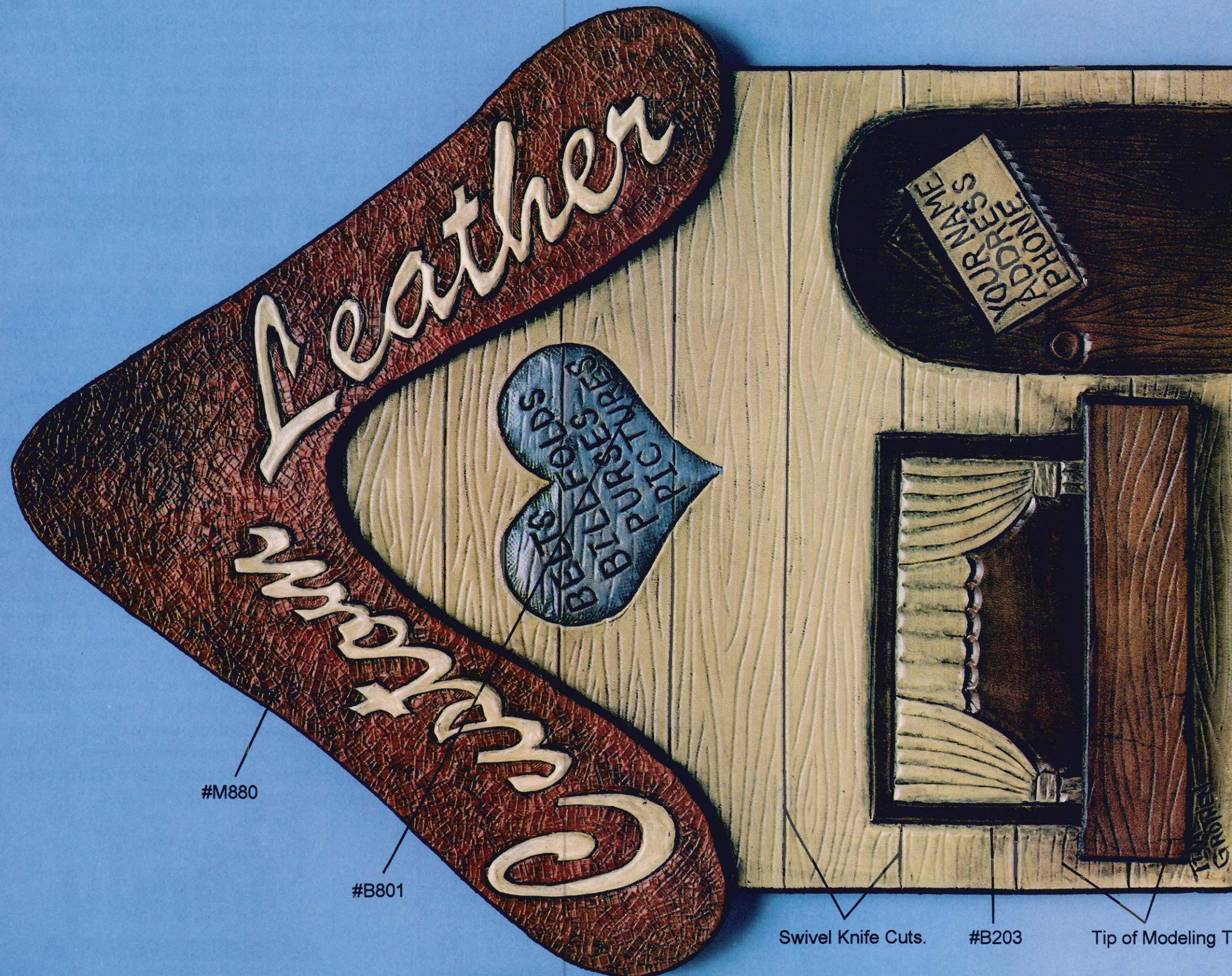

#M880

#B801

Swivel Knife Cuts.

#B203

Tip of Modeling Tool.

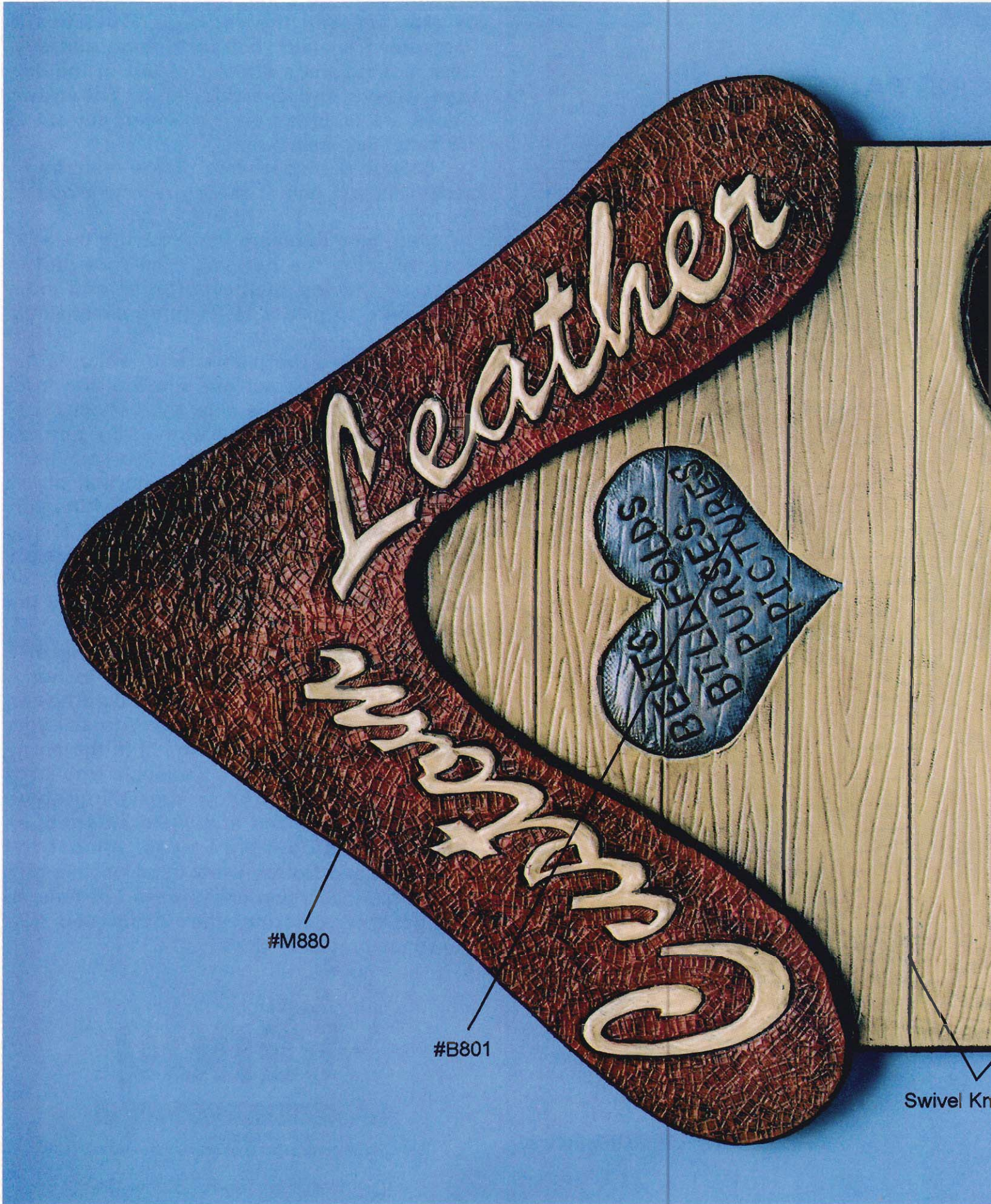

#M880

#B801

Swivel Kn

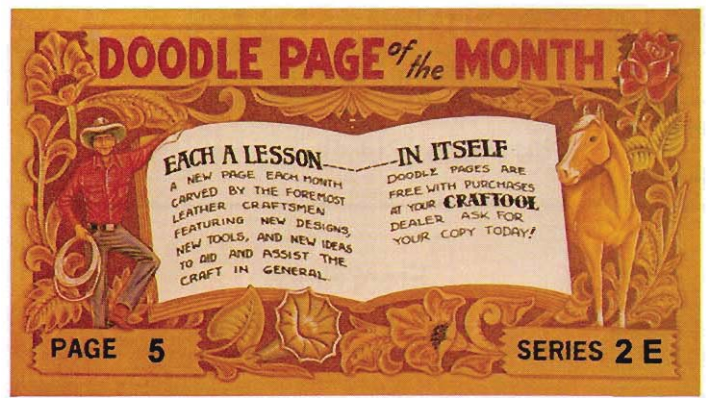

CARD HOLDER

by Tim Grothen

My wife, and I, have friends who are in the cottage industry profession on an almost full time basis. That is, they build things in their home, and distribute them to area craft stores, and area craft fairs. Business cards are an important part of their business, since it is almost their only method of advertising. Recently, they asked me if I could design some kind of card holder that would catch people's eyes. Since it was a heavy production period for them, they did not have the time to think about making something on their own. Nearly everything was left up to me, except for the wish that it would have something to do with a cottage, and would go along with their cottage industry.

This is an easy project, with fairly simple carving, but be aware that there is a bit of construction that will be necessary. It is made of 10 pieces. The tracing pattern has all the pieces on it, but some had to be overlapped, in order to fit within the area.

Many things can be changed to suit your own needs, such as the wording on the red roof. The original project had SHA-RON on it, since it is our friends business name. There are many good letter patterns in the book "ALPHABETS FOR THE LEATHERCRAFTER, #1936." You can be creative by maybe changing the heart to something more detailed, to show off your carving.

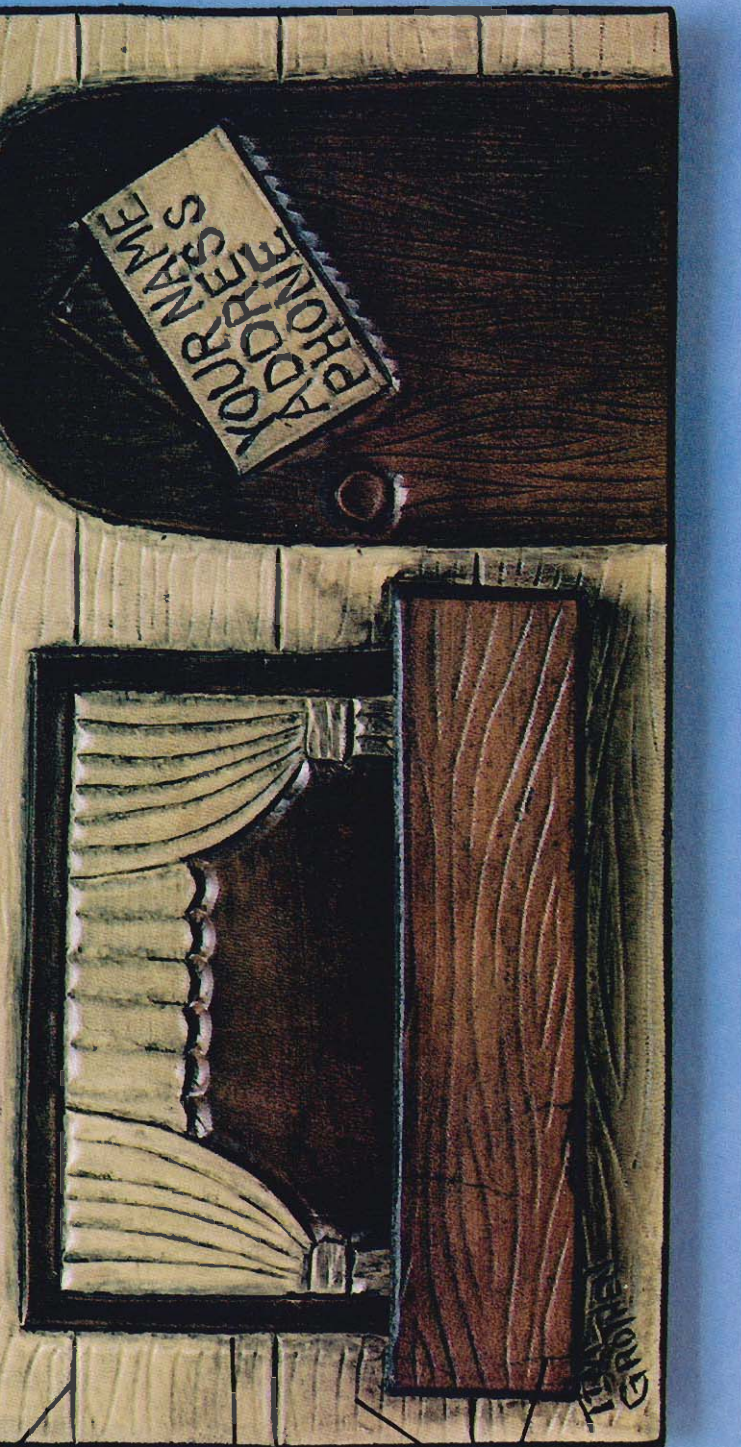

Life Cuts. #B203 Tip of Modeling Tool.

CARD HOLDER CUTTING PATTERNS

Bottom Piece (Cut 2)

Side Piece (Cut 4)

Front Piece (Cut 1)

TRACING PATTERN

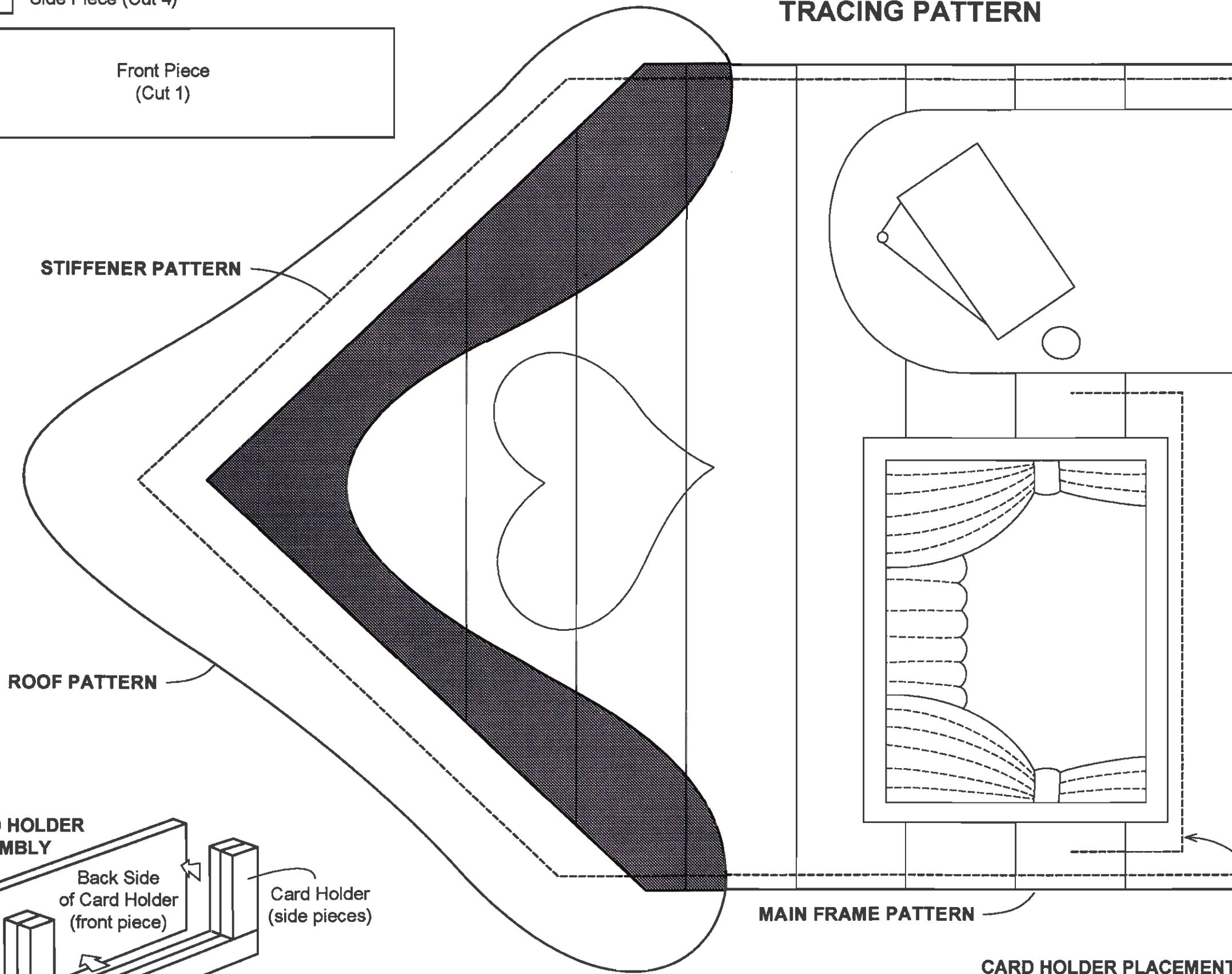

The way I go about making this project, is by starting with the red roof. Cut out the boomerang shaped roof part, carve and dye. Next, cut out the main frame part of the cottage. Carve and dye this, also. These two pieces are mounted on a stiffener, cut out of 1/8 inch thick masonite.

Skive the shaded area on the main frame part. This will give a more graceful slope to the roof.

Next, glue the main frame part to the stiffener, aligning the bottoms. The roof part is glued to the top of the stiffener and main frame part, to give a bit of three dimensional look.

Now, make the planter box, which is the card holder. First, cut out and tool the front part. Then, cut out the side and bottom parts, and glue them to the back of the front part, as shown on the cutting pattern. The completed box is now glued to the lower portion of the carved window. If you desire more of the curtains to show, mount the box lower. If you need more room for business cards, simply add more side and bottom parts, as described above. This will increase the capacity of the planter box.

A saw tooth hanger, or something else suitable, makes this project ready to hang. There are many places to hang a card holder, like this, if you are inclined to try to sell your leathercraft. It can even be hung in the entry-way of your house, for those people who know you, but don't quite know everything about you. I like to use red and white lettering, so that it catches people's eyes. Almost full strength Cova Colors were used on this project. Also, the brown areas were left natural, and got their coloring when I antiqued over the whole project. GOOD LUCK !!!



A DIVISION OF TANDY CRAFTS, INC.
AN EMPLOYEE STOCK OWNERSHIP PROGRAM CO.

Distributed by Tandy Leather Co.
Fort Worth, Texas
A Division of Tandy Crafts Inc.

© Copyright 1993, Tandy Leather Company.

No part of this or any other page may be reprinted without written permission.

CARD HOLDER CUTTING PATTERNS

Bottom Piece (Cut 2)

Side Piece (Cut 4)

Front Piece (Cut 1)

STIFFENER PATTERN

ROOF PATTERN

TRAC

MAIN FR

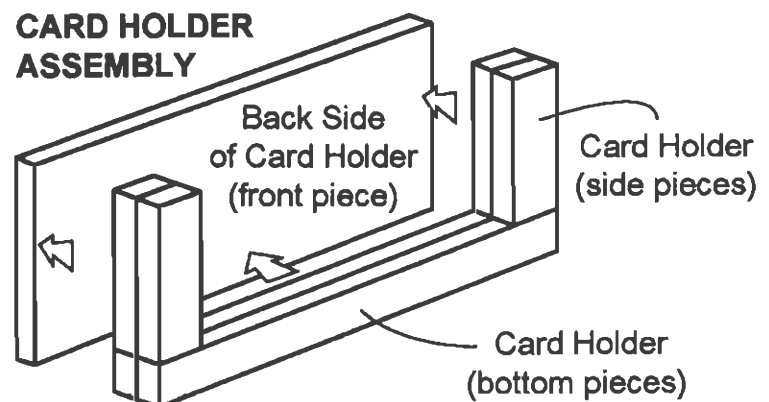

CUTTING PATTERN

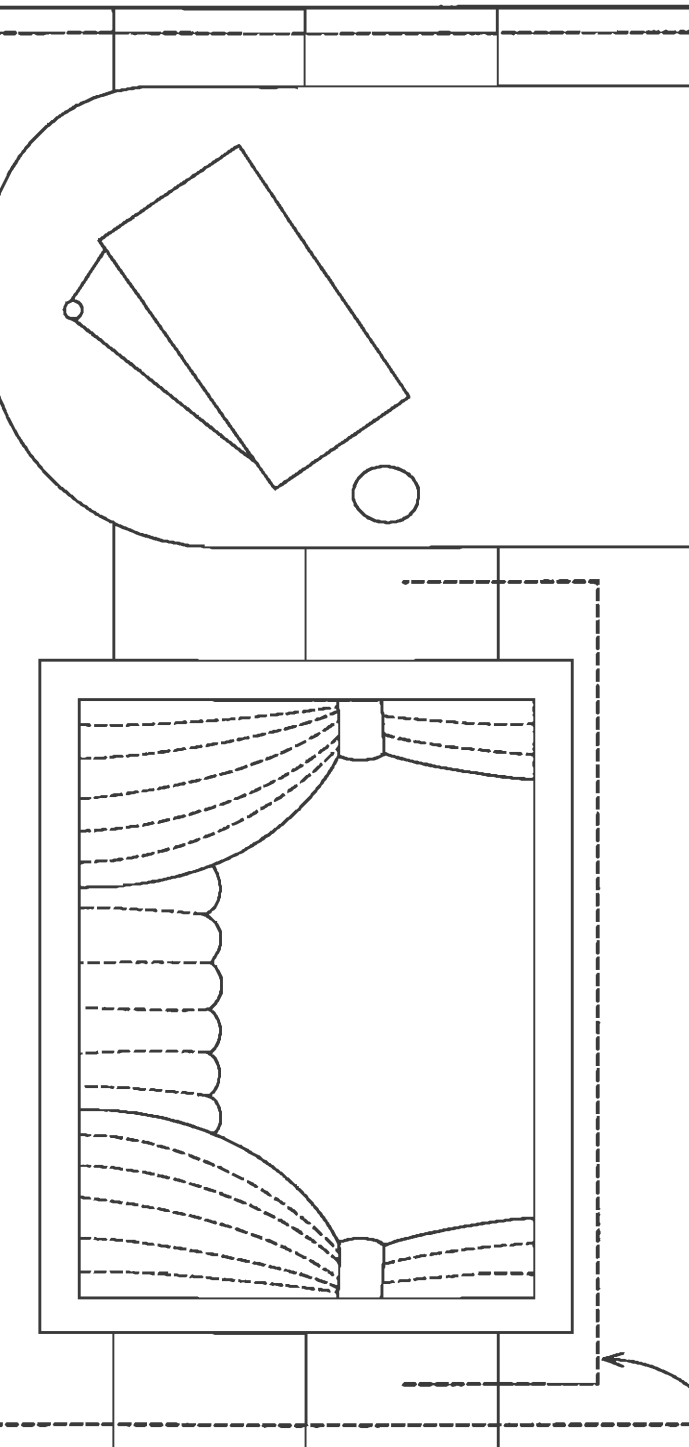

FRAME PATTERN

CARD HOLDER PLACEMENT

The way I go about making this project, is by starting with the red roof. Cut out the boomerang shaped roof part, carve and dye. Next, cut out the main frame part of the cottage. Carve and dye this, also. These two pieces are mounted on a stiffener, cut out of 1/8 inch thick masonite.

Skive the shaded area on the main frame part. This will give a more graceful slope to the roof.

Next, glue the main frame part to the stiffener, aligning the bottoms. The roof part is glued to the top of the stiffener and main frame part, to give a bit of three dimensional look.

Now, make the planter box, which is the card holder. First, cut out and tool the front part. Then, cut out the side and bottom parts, and glue them to the back of the front part, as shown on the cutting pattern. The completed box is now glued to the lower portion of the carved window. If you desire more of the curtains to show, mount the box lower. If you need more room for business cards, simply add more side and bottom parts, as described above. This will increase the capacity of the planter box.

A saw tooth hanger, or something else suitable, makes this project ready to hang. There are many places to hang a card holder, like this, if you are inclined to try to sell your leathercraft. It can even be hung in the entry-way of your house, for those people who know you, but don't quite know everything about you. I like to use red and white lettering, so that it catches people's eyes. Almost full strength Cova Colors were used on this project. Also, the brown areas were left natural, and got their coloring when I antiqued over the whole project. GOOD LUCK !!!

tandy
LEATHER COMPANY

A DIVISION OF TANDY CRAFTS, INC.
AN EMPLOYEE STOCK OWNERSHIP PROGRAM CO.

Distributed by Tandy Leather Co.
Fort Worth, Texas
A Division of Tandy Crafts Inc.