

MOCCASIN PATTERNS

by GENE NOLAND

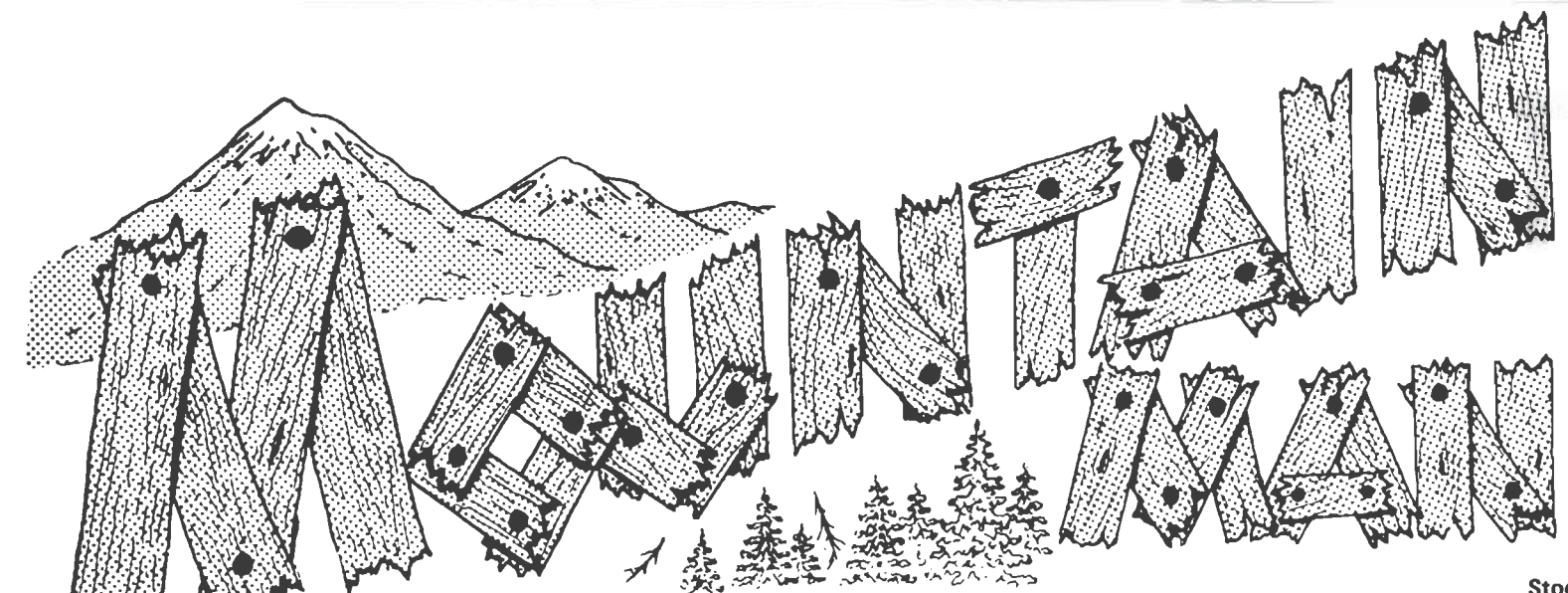

ASSEMBLY INSTRUCTIONS

#1

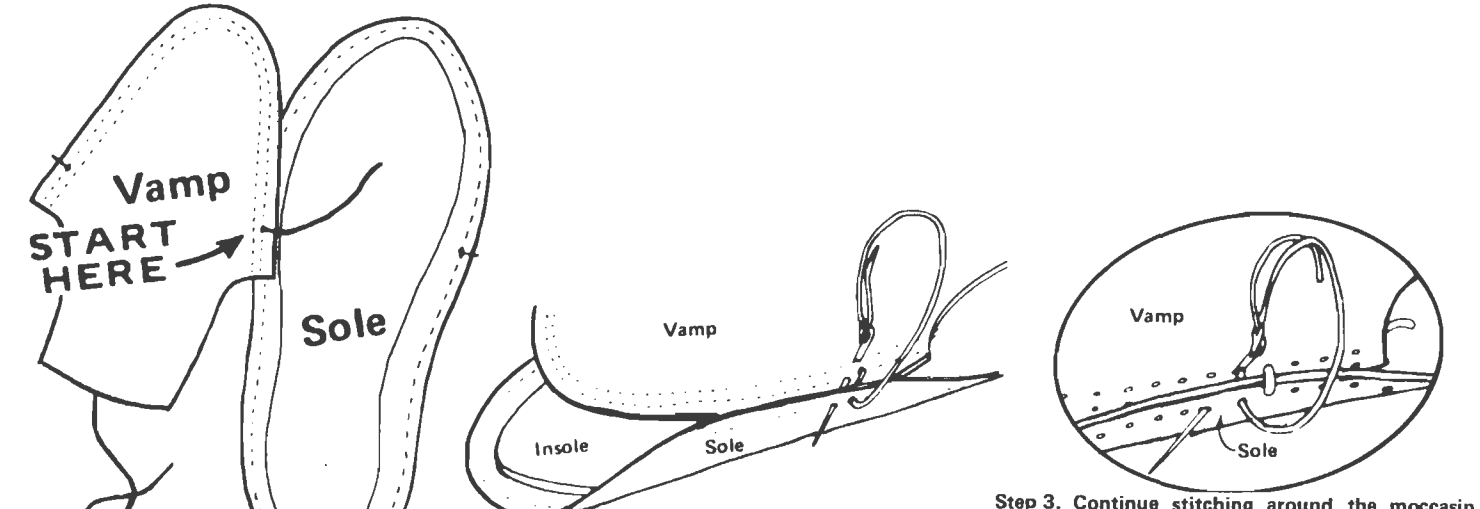

Step 1. Begin by placing the right sole on a working surface with the insole facing up. Align the diamond hole in the vamp with the diamond hole in the sole.

Step 2. From the outside of the moccasin, insert the needle through the hole in the vamp above the diamond hole, and then back through the vamp and sole as shown. Pull the stitch snug, but not extremely tight as this will reduce the overall size of the moccasin.

Step 3. Continue stitching around the moccasin in this manner to the last hole before the diamond hole on the other side of the moccasin.

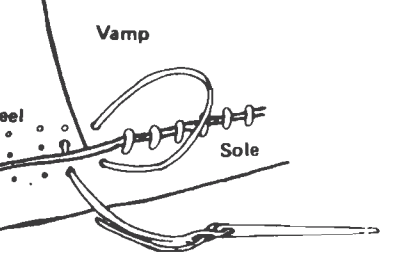

Step 4. Align the first hole in the heel cuff with the diamond shaped hole in the sole. Stitch through the next hole in the vamp to the inside of the moccasin, and back through the bottom hole in the vamp through the heel cuff and the sole. Continue stitching around the moccasin to the last hole.

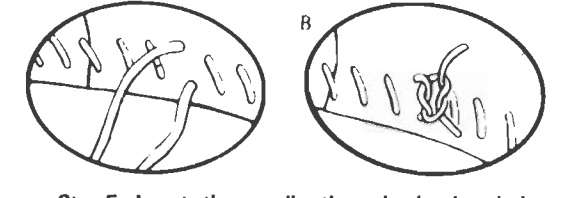

Step 5. Insert the needle through the last hole in the heel cuff and vamp to the inside of the moccasin. The inside of the moccasin will appear as in illustration "A". Tie the ends of the thread in a double knot as shown in illustration "B" and cut off the excess thread.

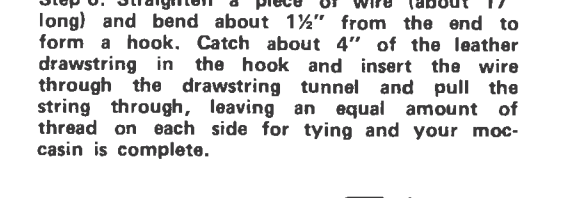

Step 6. Straighten a piece of wire (about 17" long) and bend about 1/2" from the end to form a hook. Catch about 4" of the leather drawstring in the hook and insert the wire through the drawstring tunnel and pull the string through, leaving an equal amount of thread on each side for tying and your moccasin is complete.

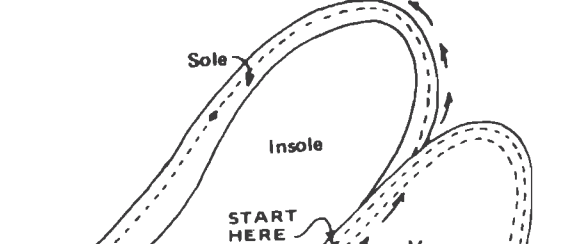

Step 7. Place the left sole on a working surface with the insole facing up. Align the diamond hole in the vamp with the diamond hole in the sole. Assemble the left moccasin exactly as you did the right one, stitching around the moccasin as shown.

MOCCASIN PATTERNS

by GENE NOLAND

Stock No. 2695



Needle Threading Instructions

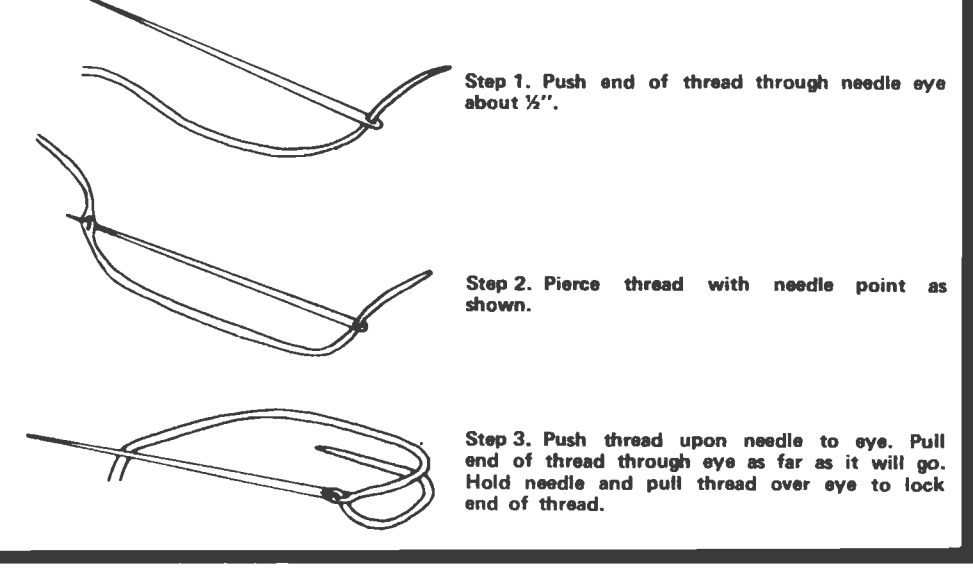

DIRECTIONS

Choose a good leather for making your moccasins, one that is durable and soft. You may cut your own insoles if you have the material or use the ones found in the drug stores. Glue the insoles in position on the sole leather as shown.

Draw your Indian designs on before you assemble the moccasins. The New "Glad Rag" work very well on light colored suede leather. If darker leather is used, the white base coat should be used first to bring out the color brilliance.

The heel cuff is made in two parts. One is the cuff part and the other is the heel part. They are indicated in the heel cuff tracing pattern. These two parts are then stitched together to form a drawingstring tunnel. If you wish you might add sheep wool to the cuff area or cover the whole heel cuff pattern. If the wool is added to the cuff it should be glued and then stitched on, about 1/4" in along the edge, except for the points at the drawstring tunnel openings.

If you follow the assembling instructions carefully, you should not have any problems in making these moccasins.

Start by cutting out the patterns, remembering to reverse the patterns for the LEFT foot. Next punch all the holes and draw on the designs. Then begin your assembling.

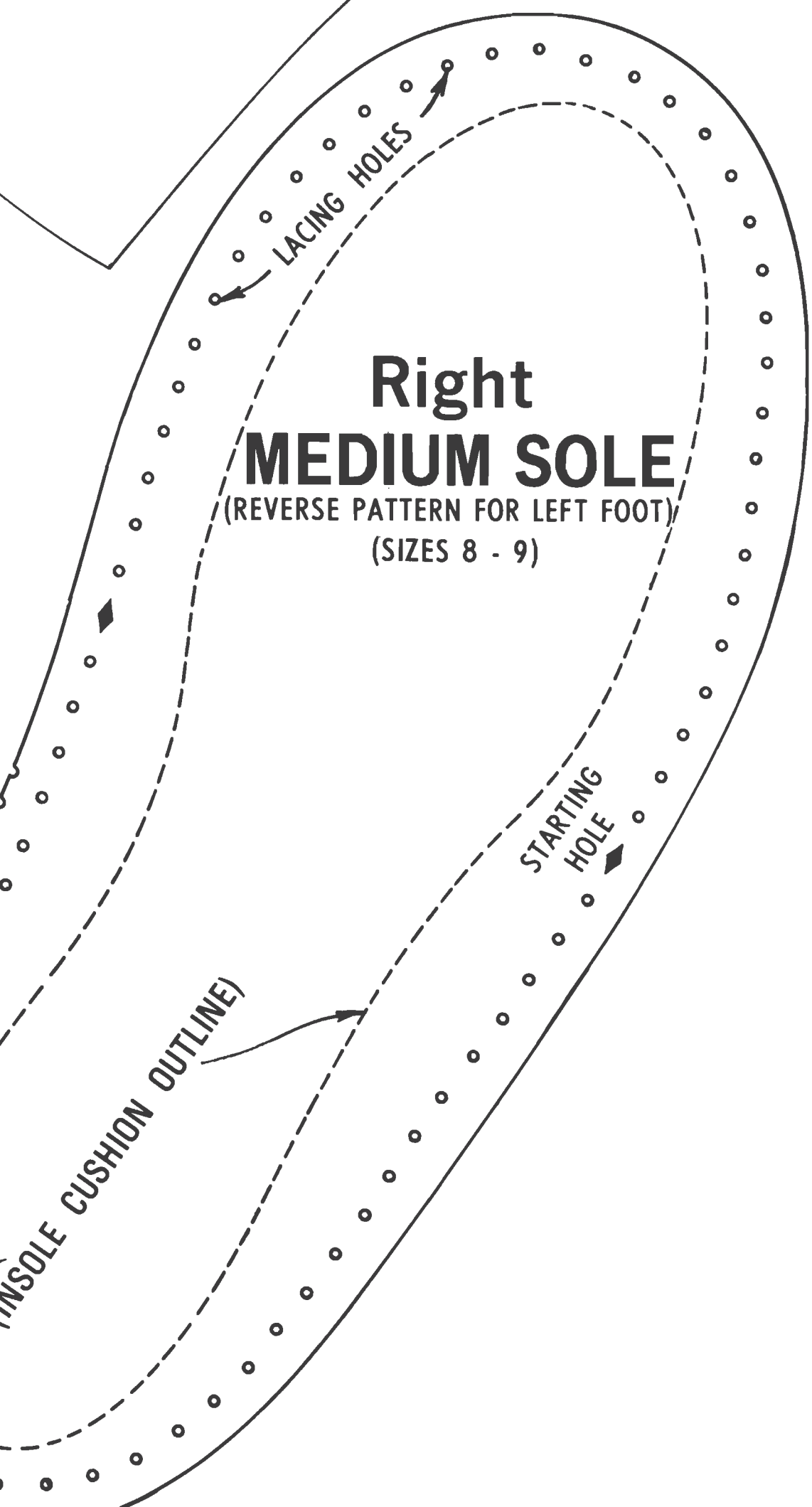
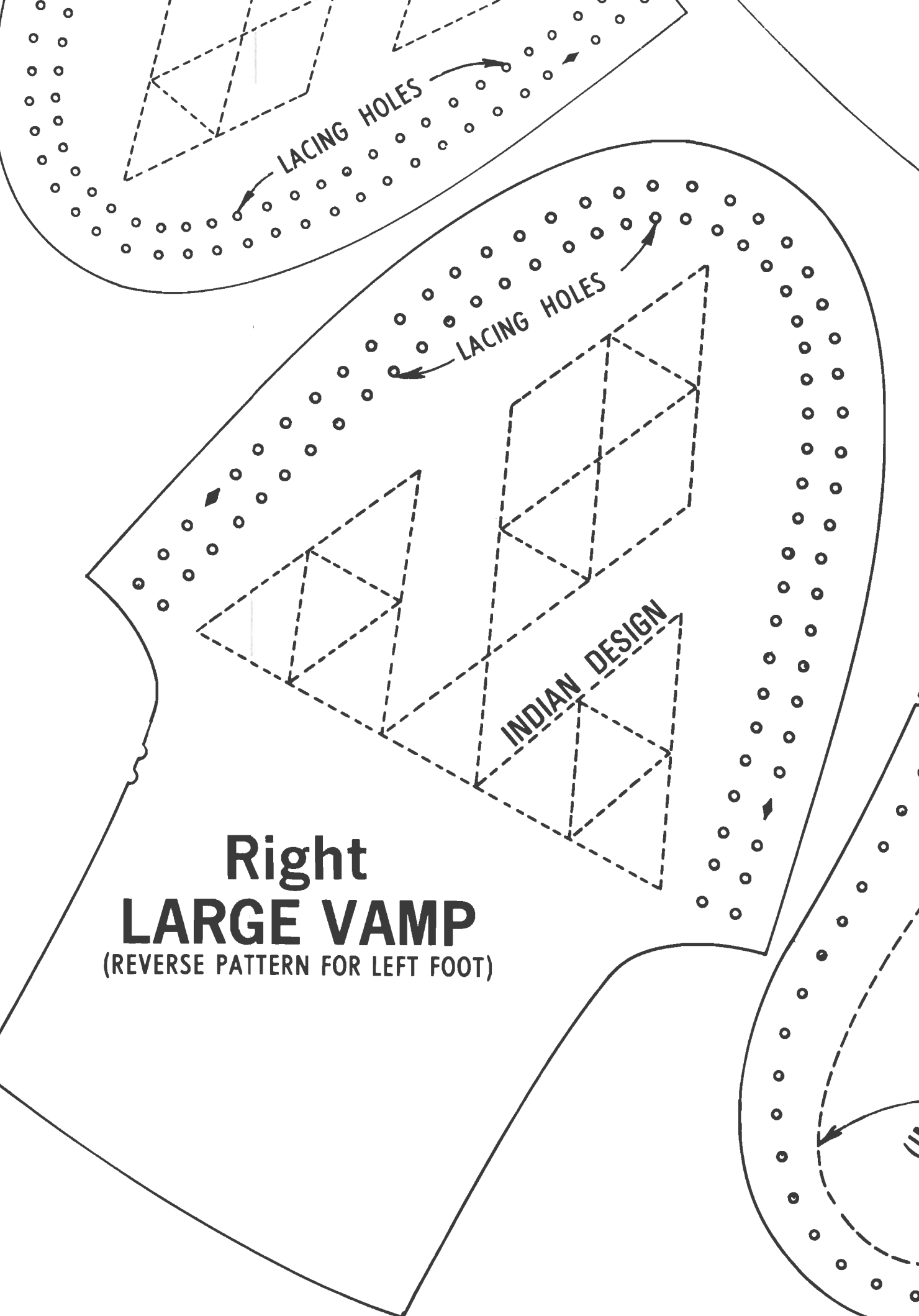
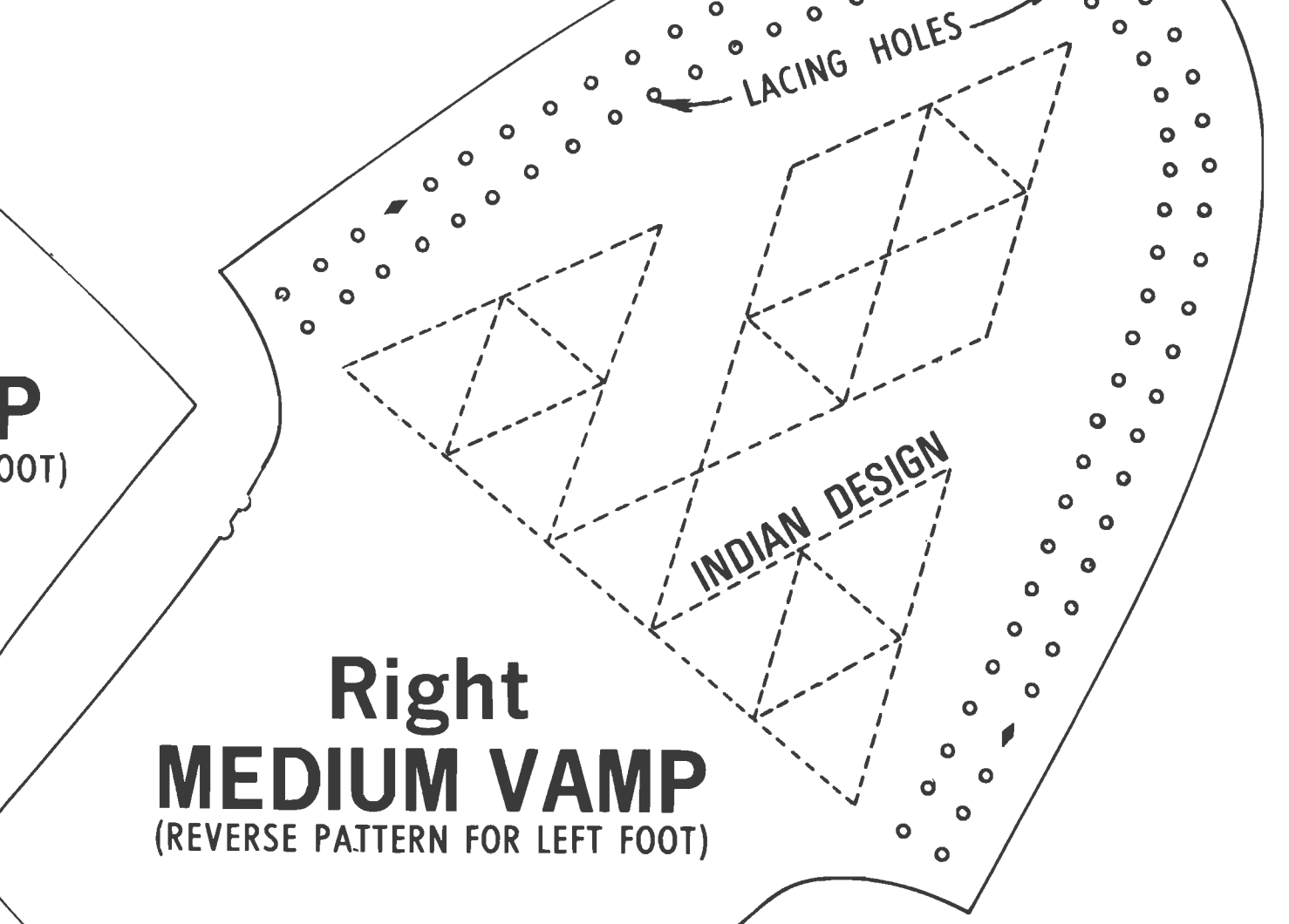
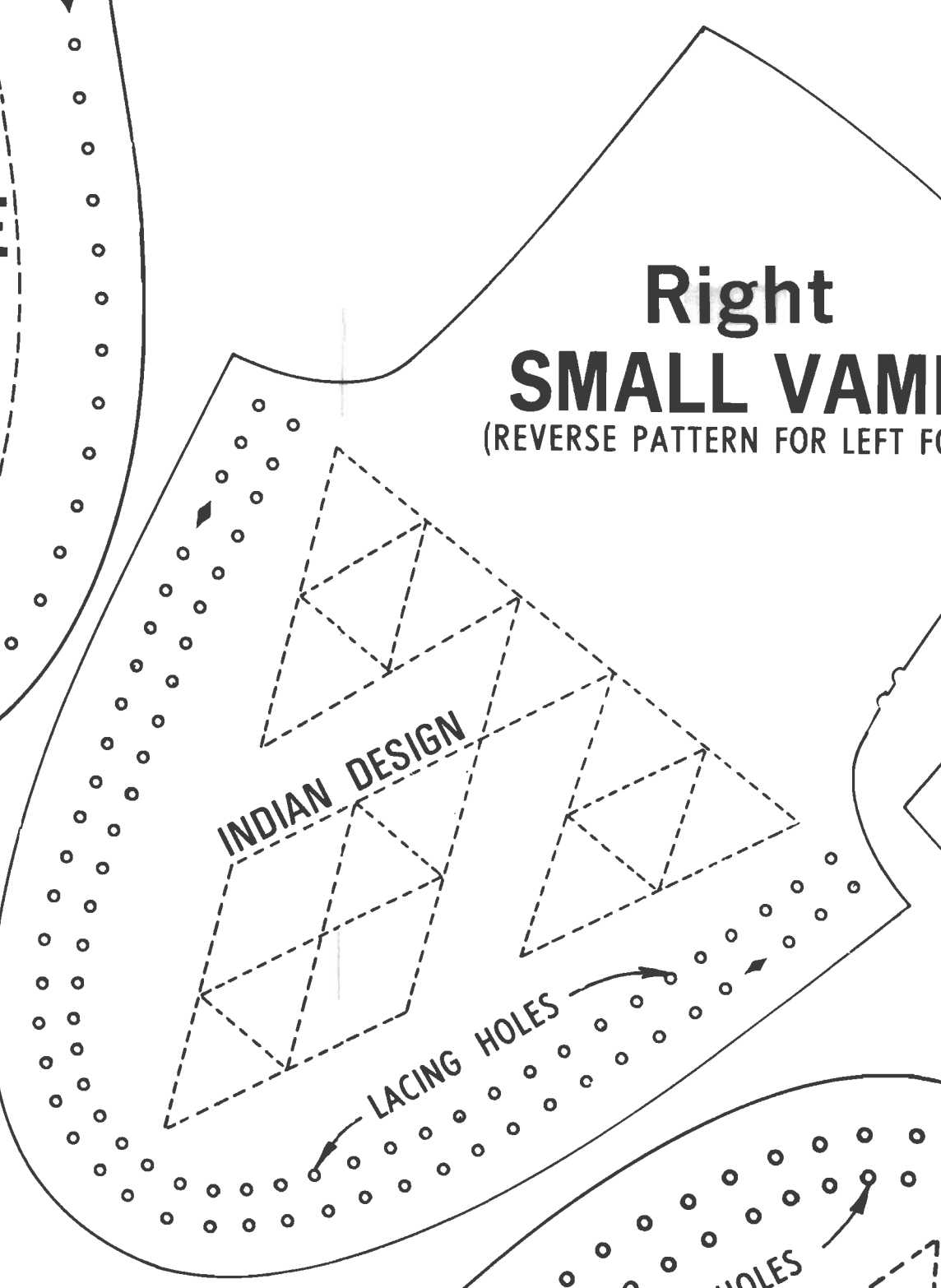
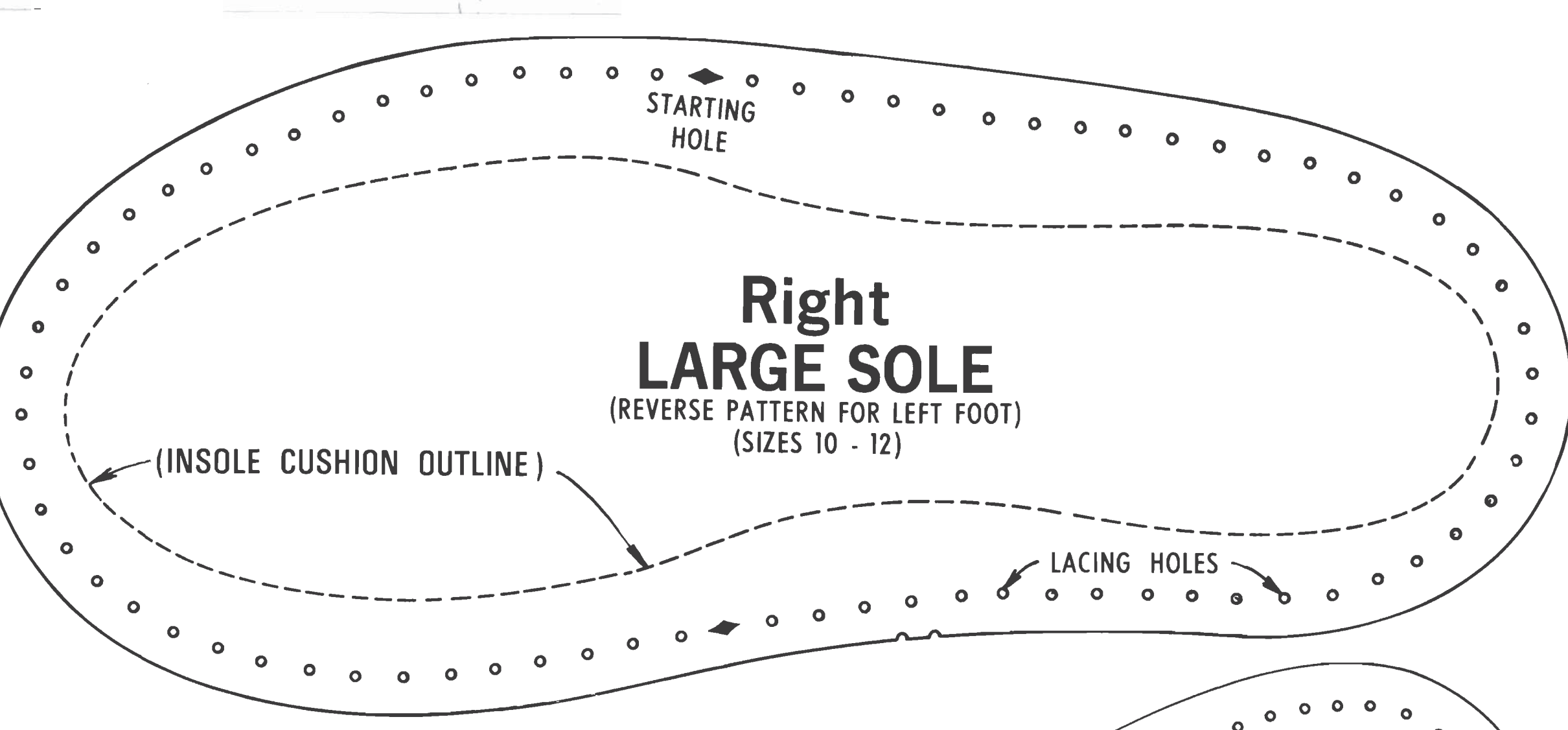
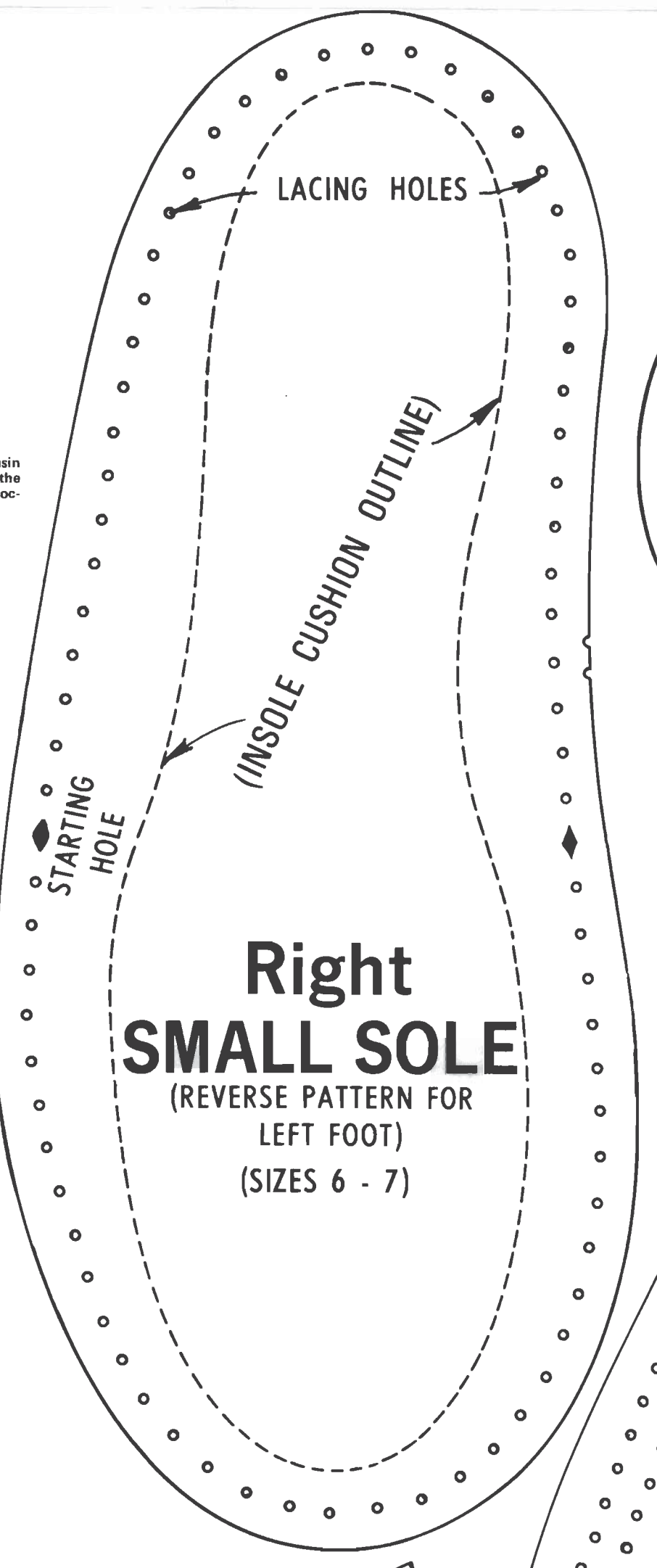
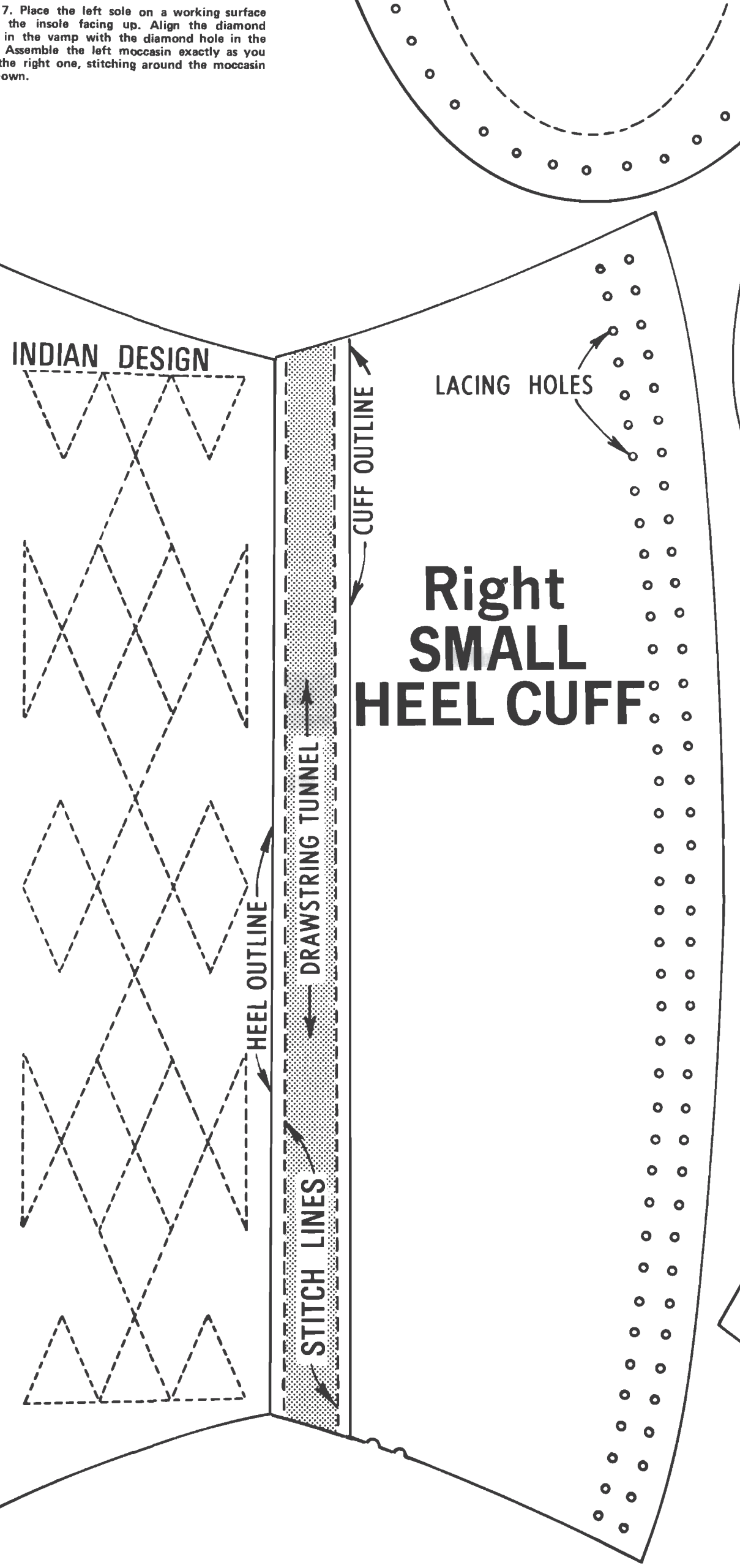
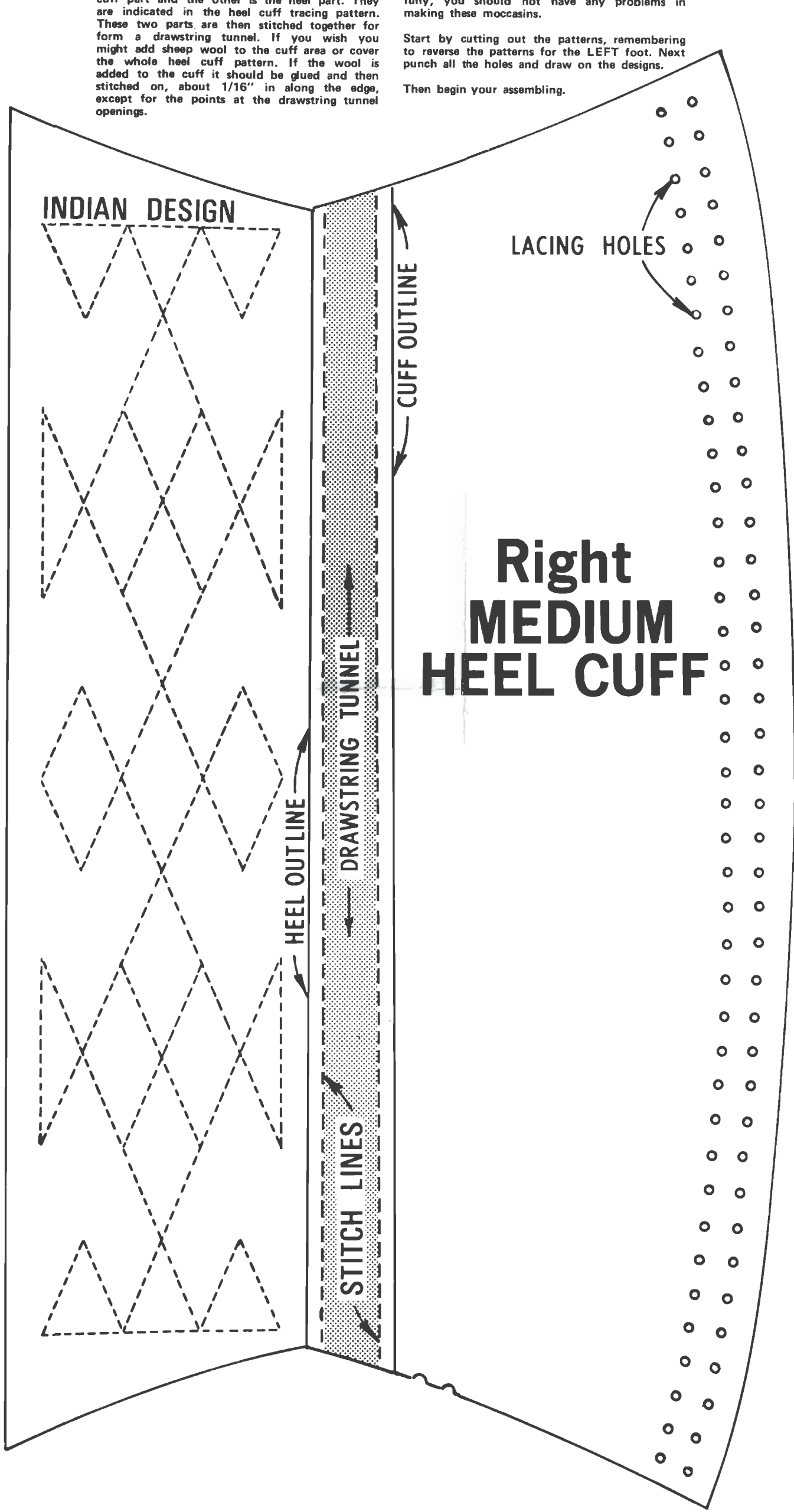
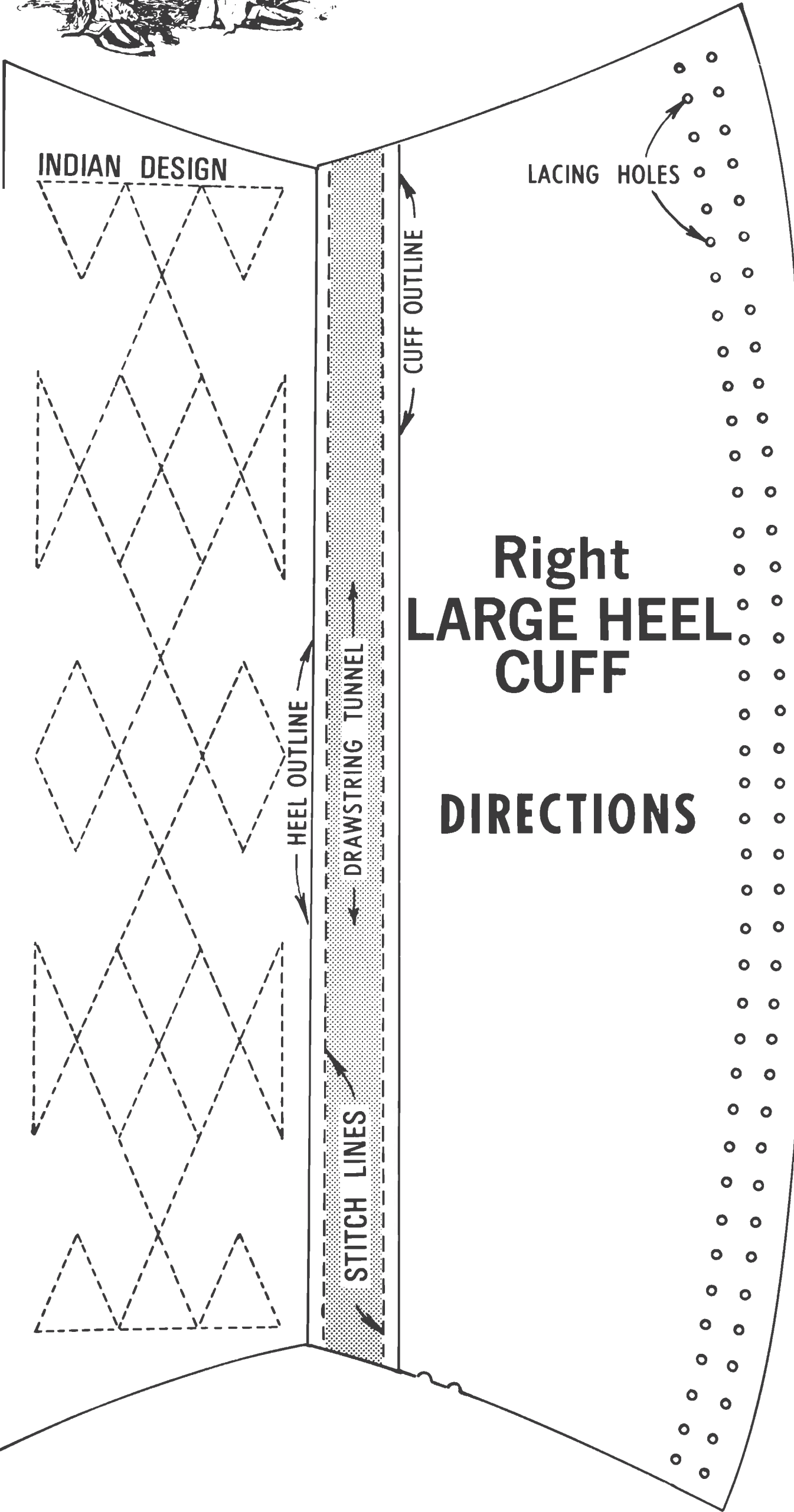

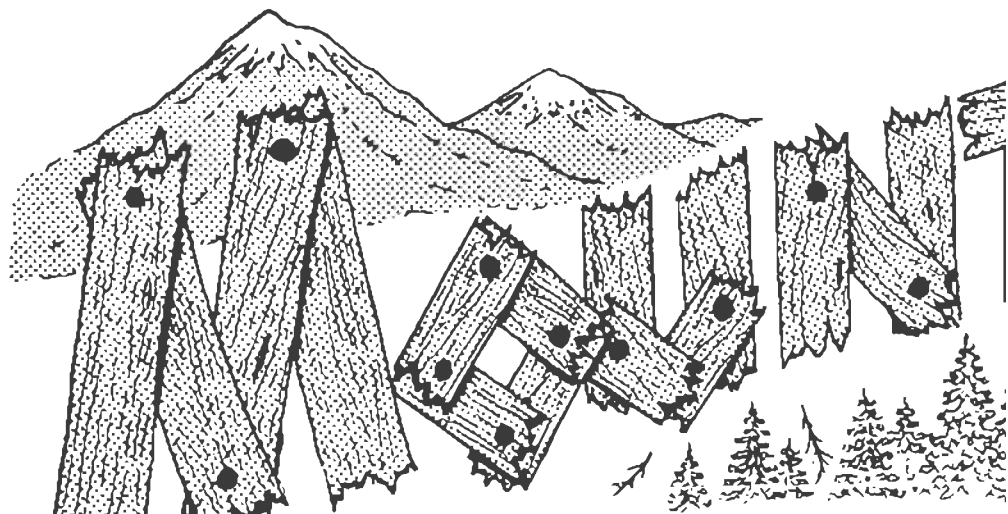

MOCCASII

by



Needle
Inst

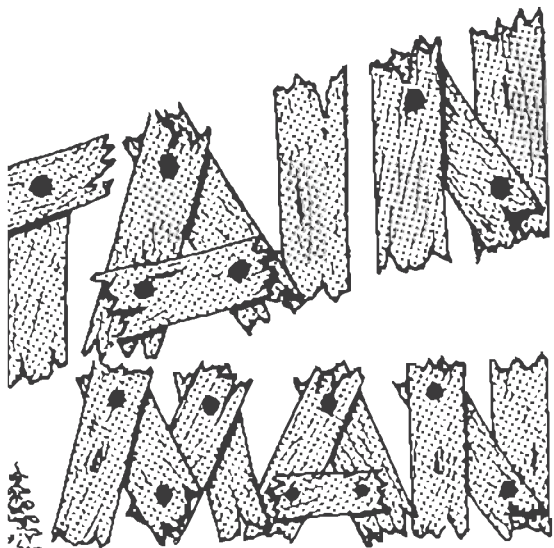

ASSEMBLY INSTRUCTION

#1

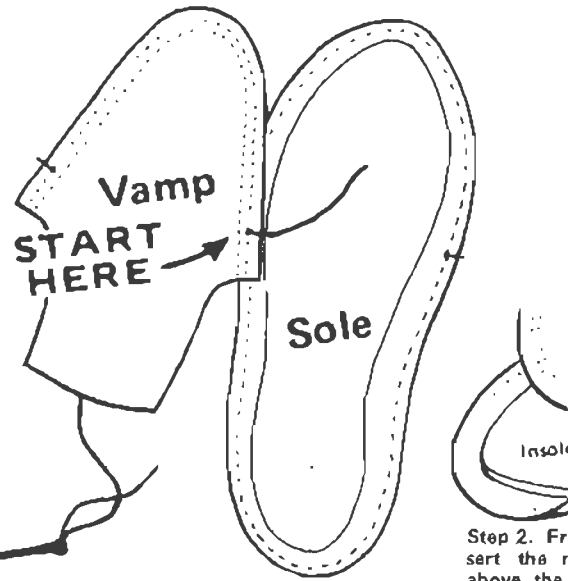

Stock No. 2695

N PATTERNS

GENE NOLAND

Step 1. Begin by placing the right sole on a working surface with the insole facing up. Align the diamond hole in the vamp with the diamond hole in the sole.

From the inside of the moccasin, insert the needle through the diamond hole in the vamp, then through the diamond hole in the sole. Pull the needle and thread through to the outside of the moccasin leaving about 4" of thread inside the moccasin.

Step 2. Fr
sert the r
above the
the vamp
snug, but
the overall

Threading ructions

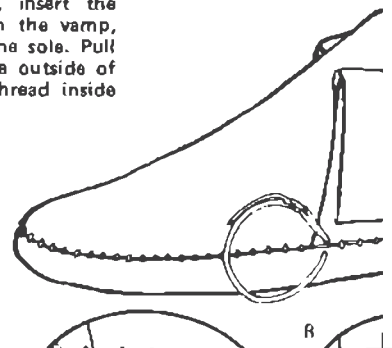
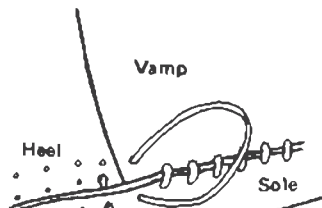

IS

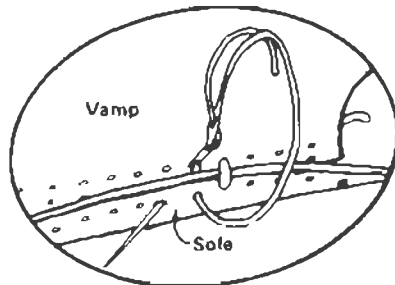
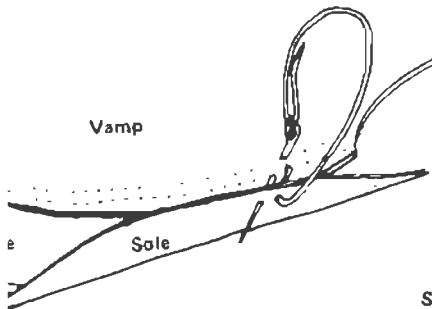

Step 3. Continue stitching around the moccasin in this manner to the last hole before the diamond hole on the other side of the moccasin.

om the outside of the moccasin, in-
eedle through the hole in the vamp
diamond hole, and then back through
and sole as shown. Pull the stitch
not extremely tight as this will reduce
size of the moccasin.

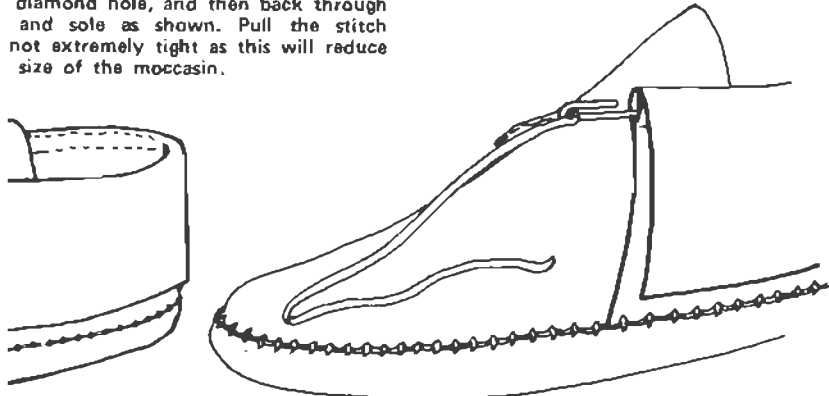

Step 6. Straighten a piece of wire (about 17" long) and bend about 1 1/2" from the end to

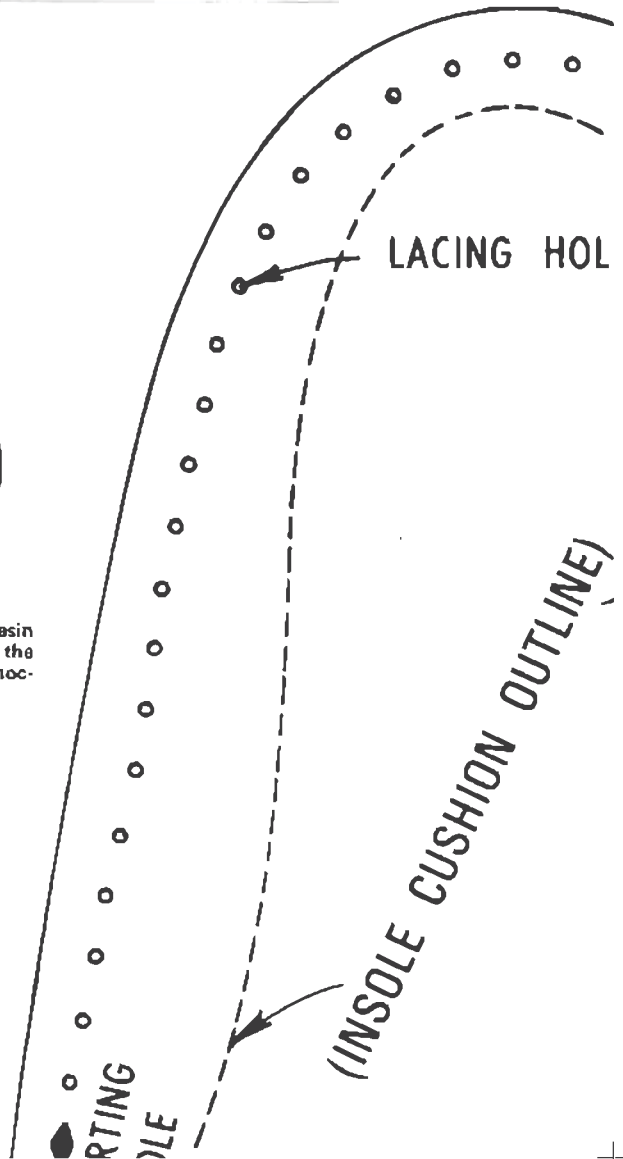

RTING
OLE

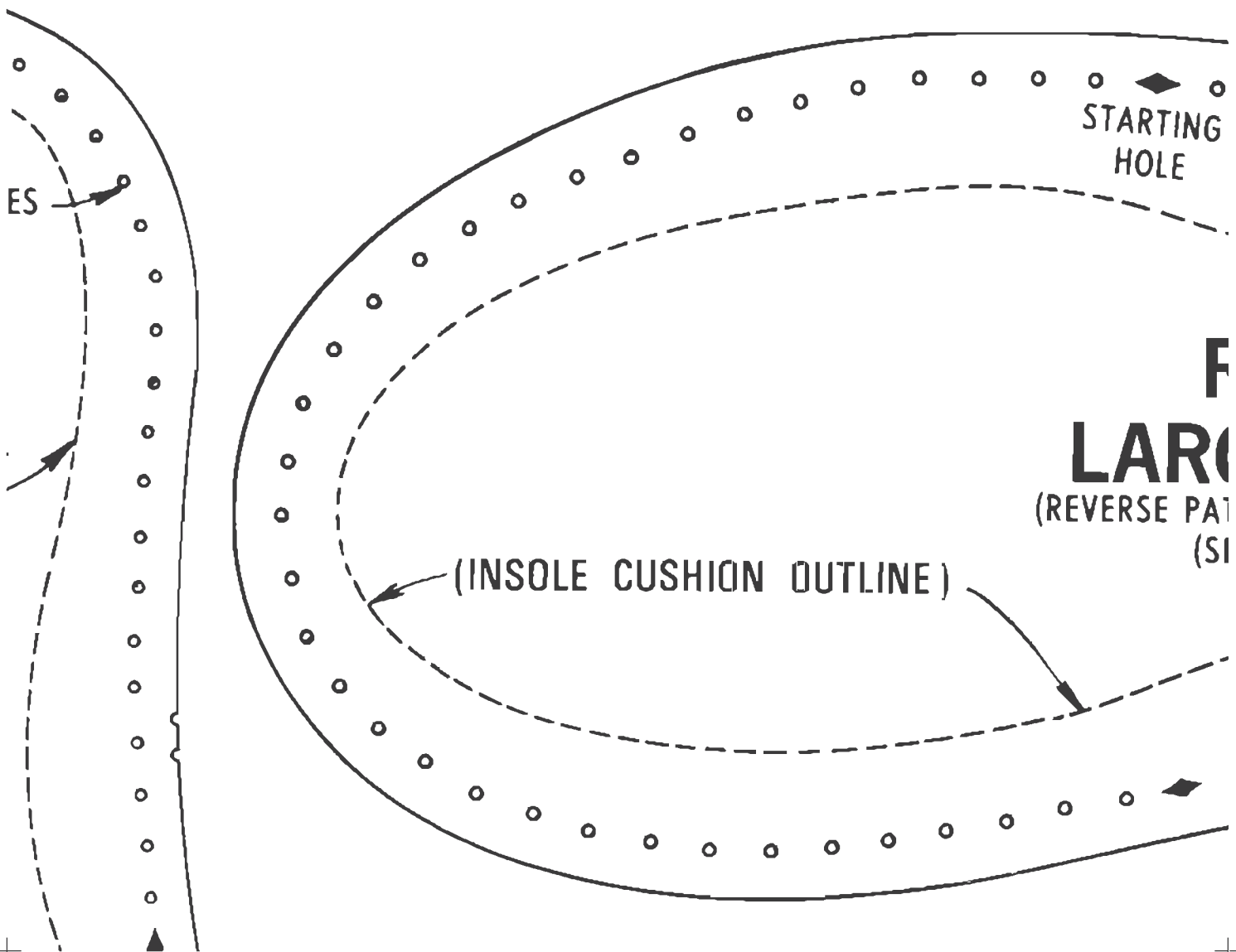

Right
SOLE
(PATTERN FOR LEFT FOOT)
(SIZES 10 - 12)

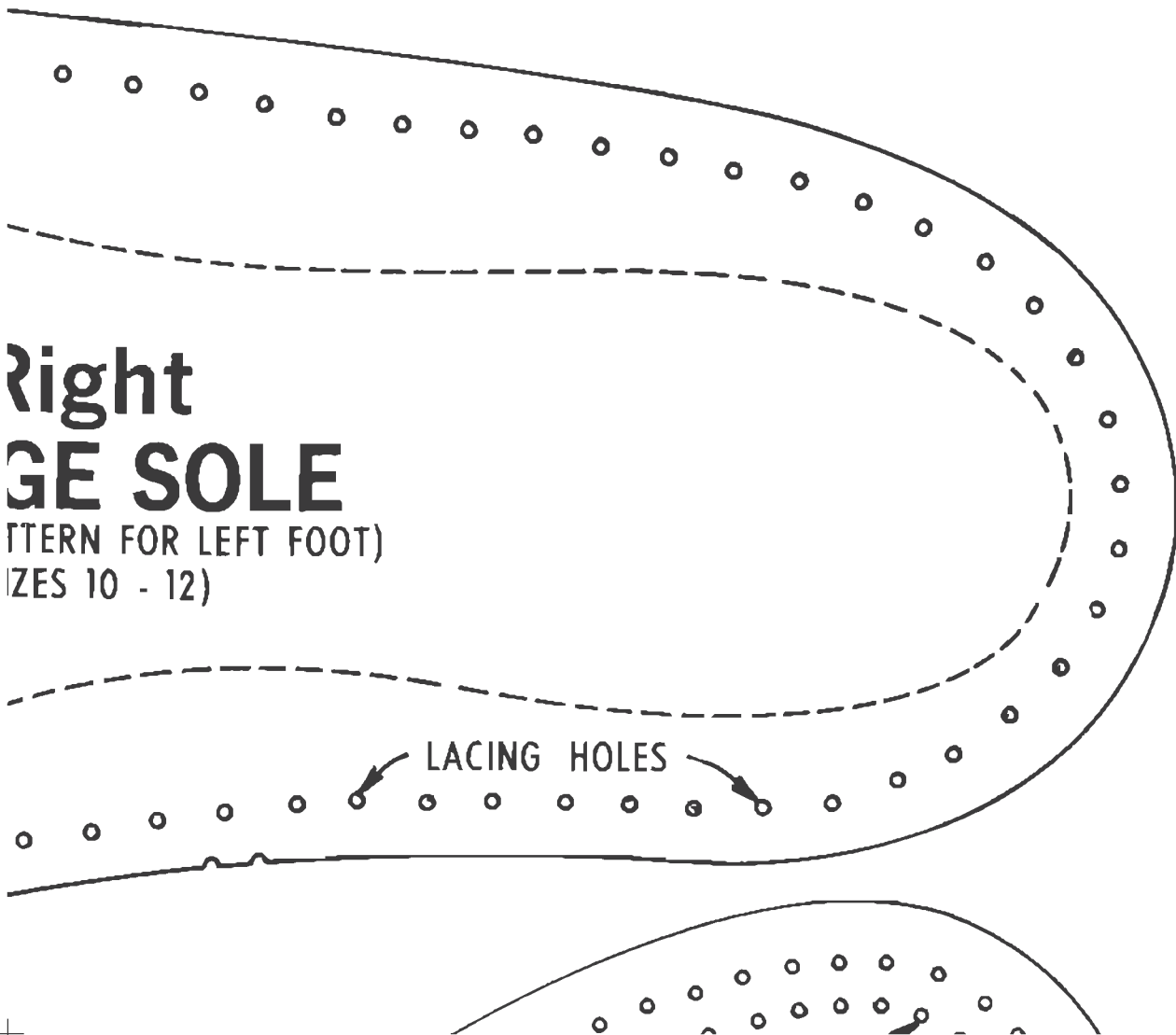

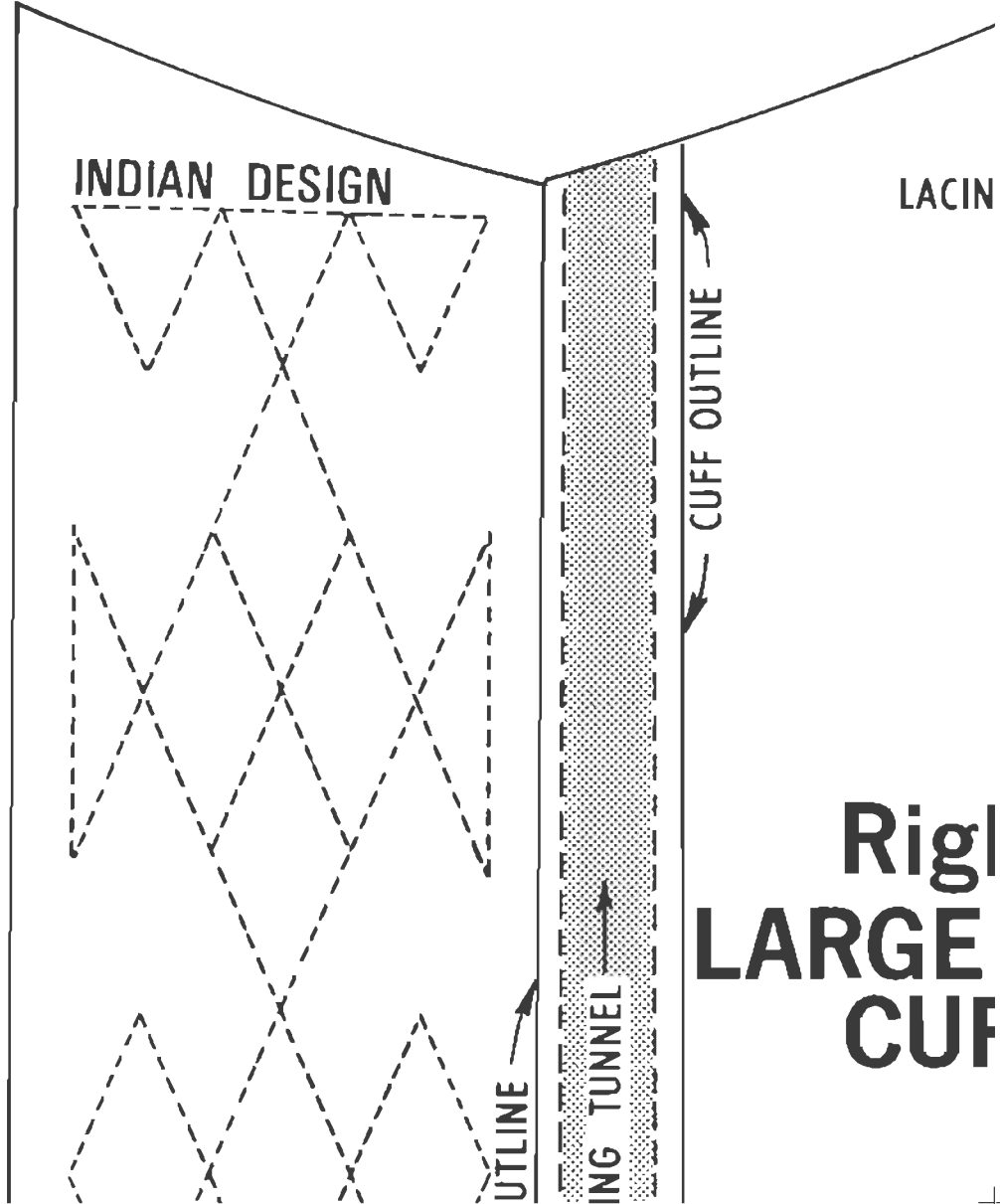
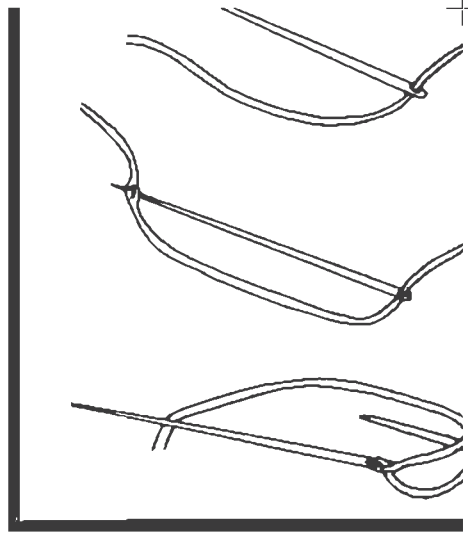

Step 1. Push end of thread through needle eye about 1/2".

Step 2. Pierce thread with needle point as shown.

Step 3. Push thread upon needle to eye. Pull end of thread through eye as far as it will go. Hold needle and pull thread over eye to lock end of thread.



Step 4. Align the first hole in the heel cuff with the diamond shaped hole in the sole. Stitch through the next hole in the vamp to the inside of the moccasin, and back through the bottom hole in the vamp through the heel cuff and the sole. Continue stitching around the moccasin to the last hole.



Step 5. Insert the needle through the heel cuff and vamp to the inside of the moccasin. The inside of the moccasin appears as in illustration "A". Tie the ends of the thread in a knot as shown in illustration "B" and cut the thread.

DIRECTIONS

Choose a good leather for making your moccasins, one that is durable and soft. You may cut your own insoles if you have the material or use the ones found in the drug stores. Glue the insoles in position on the sole leather as shown.

Draw your Indian designs on the leather before you assemble the moccasins. The "N Rags" work very well on light color leather. If darker leather is used, the wax coat should be used first to bring out the brilliance.

The heel cuff is made in two parts. One is the cuff part and the other is the heel part. They are indicated in the heel cuff tracing pattern. These two parts are then stitched together to form a drawstring tunnel. If you wish you might add sheep wool to the cuff area or cover the whole heel cuff pattern. If the wool is added to the cuff it should be glued and then stitched on, about 1/16" in along the edge, except for the points at the drawstring tunnel openings.

If you follow the assembling instructions fully, you should not have any problems making these moccasins.

Start by cutting out the patterns, and then reverse the patterns for the LEFT moccasin. Punch all the holes and draw on the Indian designs.

Then begin your assembling.

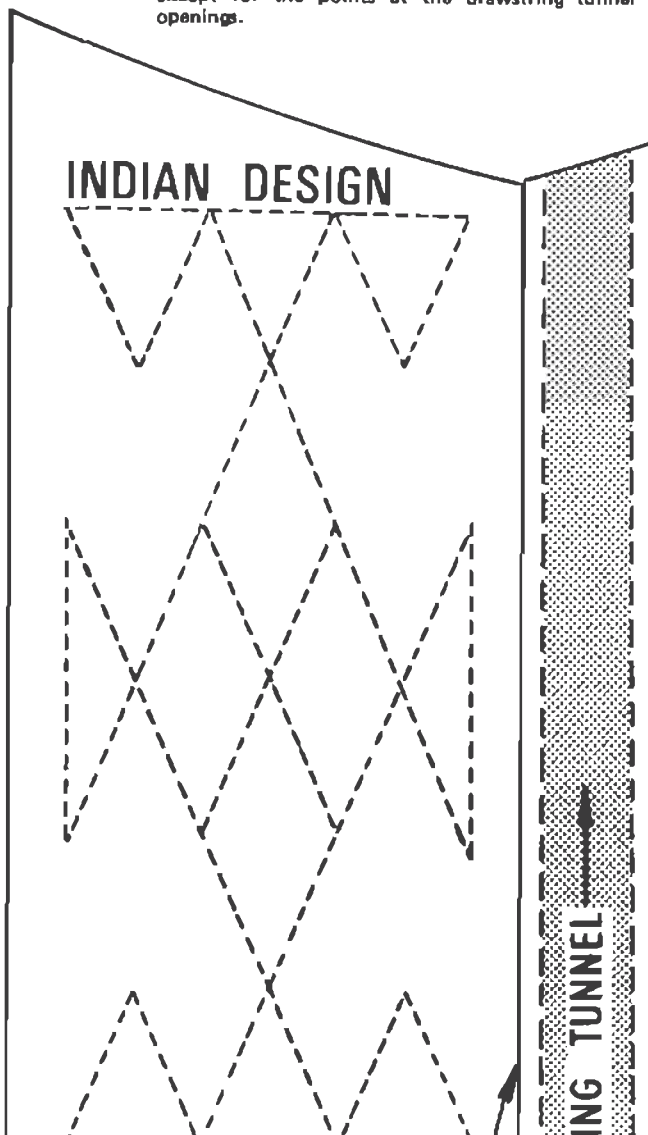
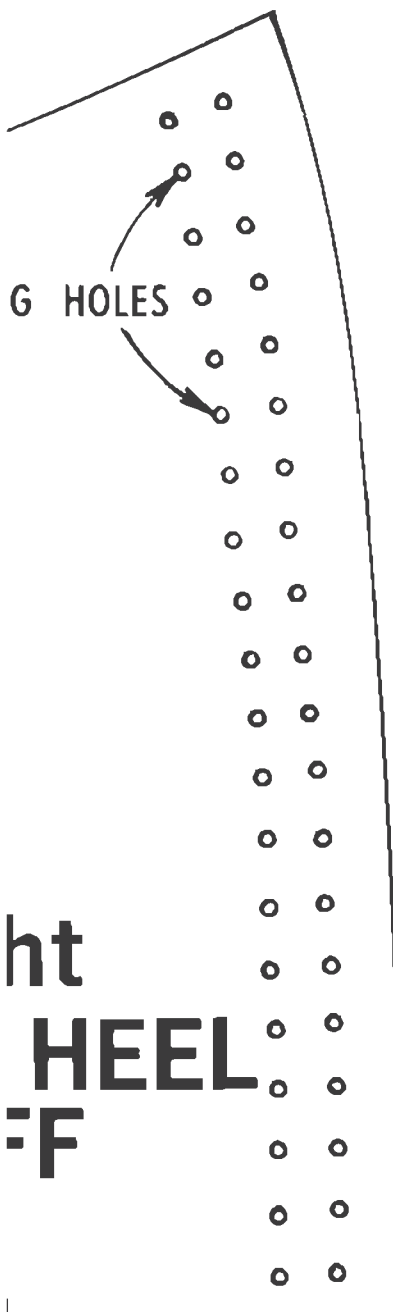

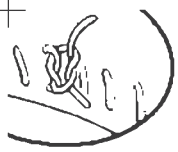

form a hook. Catch about 4" of the leather drawstring in the hook and insert the wire through the drawstring tunnel and pull the string through, leaving an equal amount of thread on each side for tying and your moccasin is complete.

When the last hole is made inside of the moccasin will

... double knot as it off the excess

Before you sew "Glad colored suede white base at the color

Directions care-problems in

Remembering foot. Next designs.

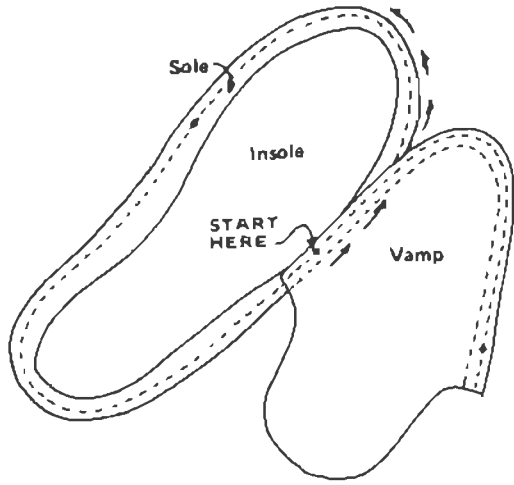

Step 7. Place the left sole on a working surface with the insole facing up. Align the diamond hole in the vamp with the diamond hole in the sole. Assemble the left moccasin exactly as you did the right one, stitching around the moccasin as shown.

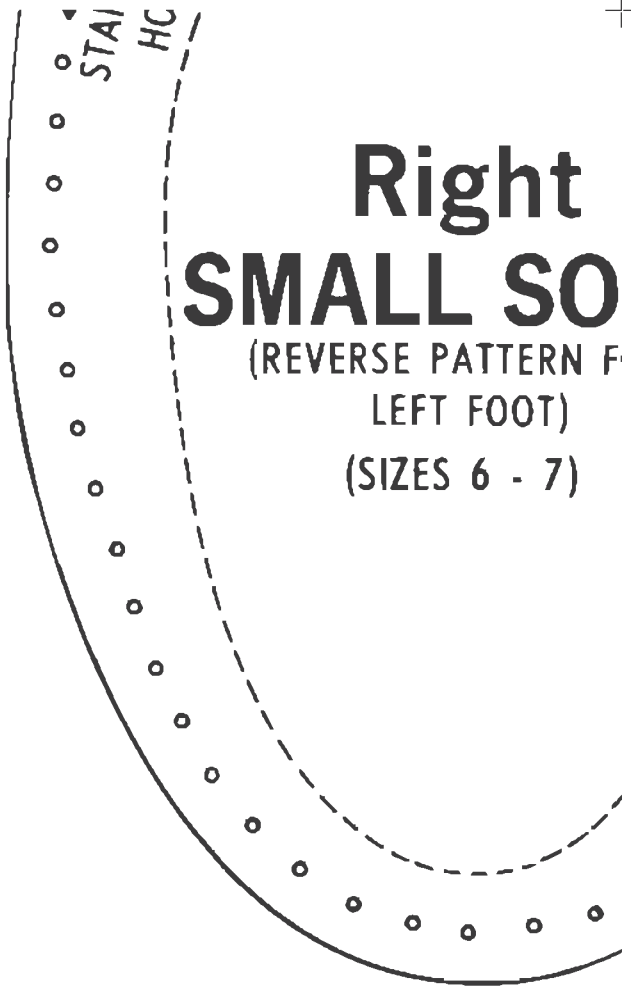

Right SMALL SOLE

(REVERSE PATTERN FOR LEFT FOOT)
(SIZES 6 - 7)

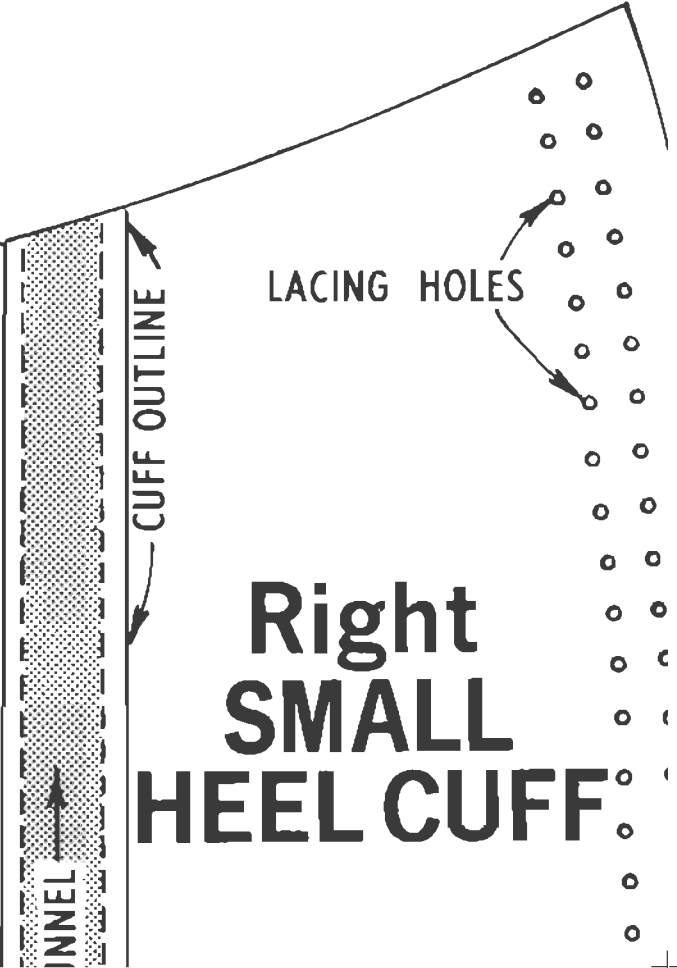
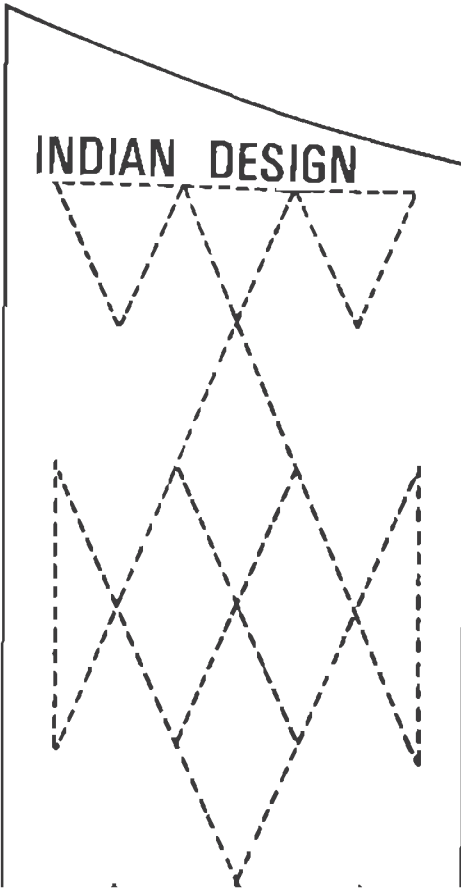
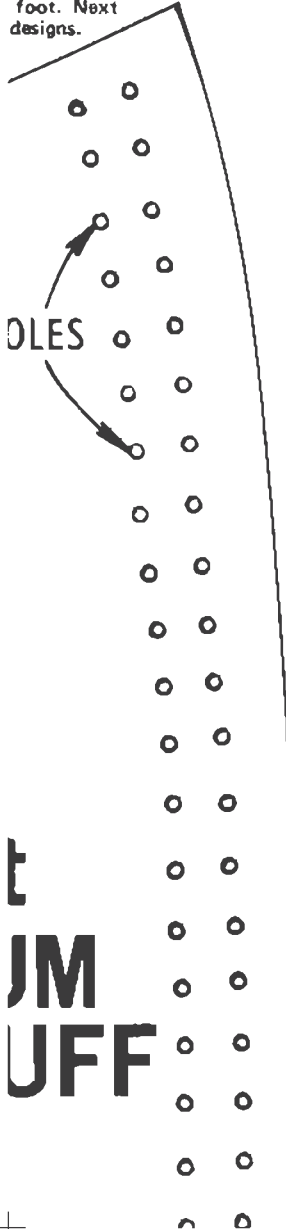

Right SMALL HEEL CUFF

LE
OR

Right SMALL VAMP

(REVERSE PATTERN FOR LEFT FOOT)

M
(RE

INDIAN DESIGN

LACING HOLES

LACING HOLES

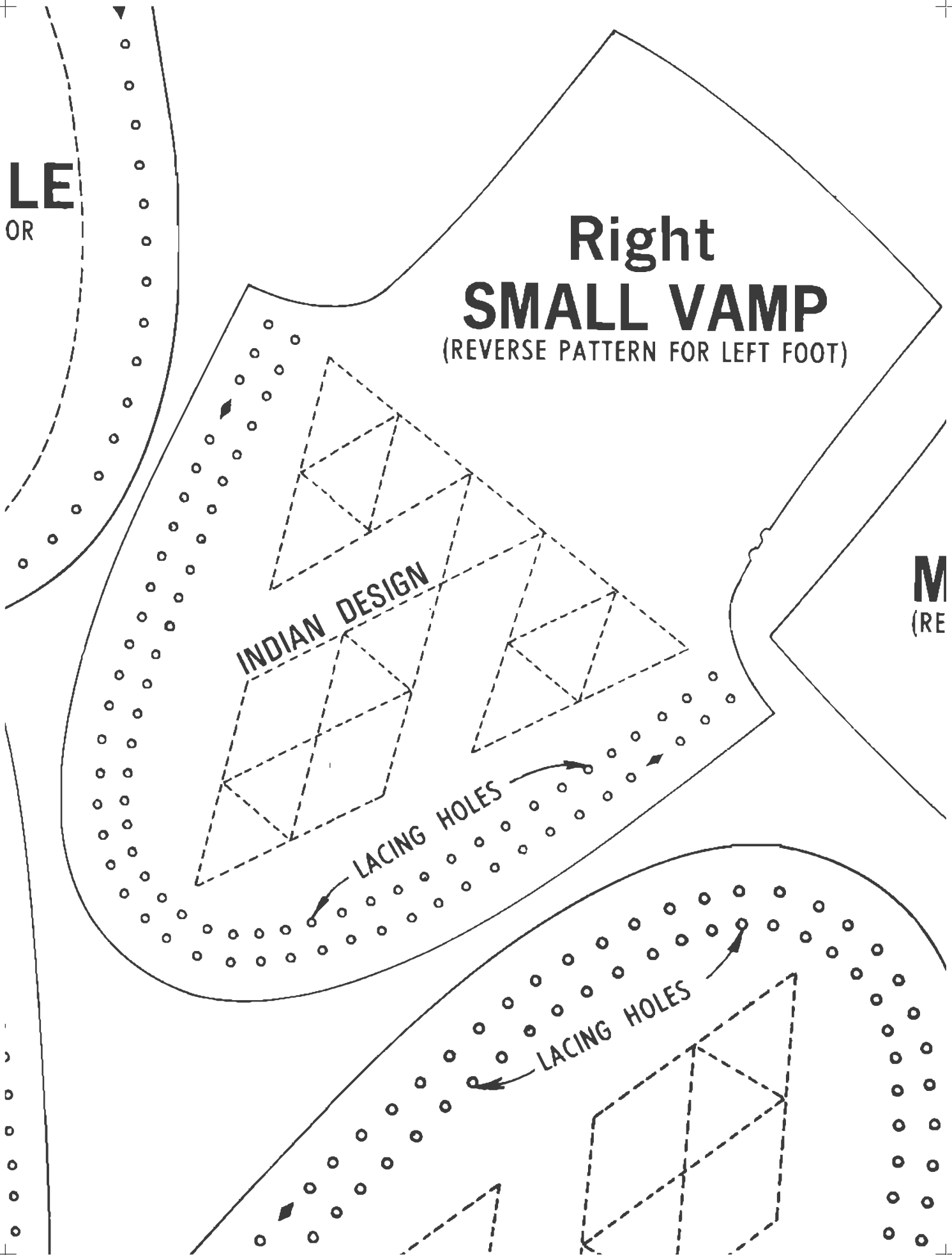

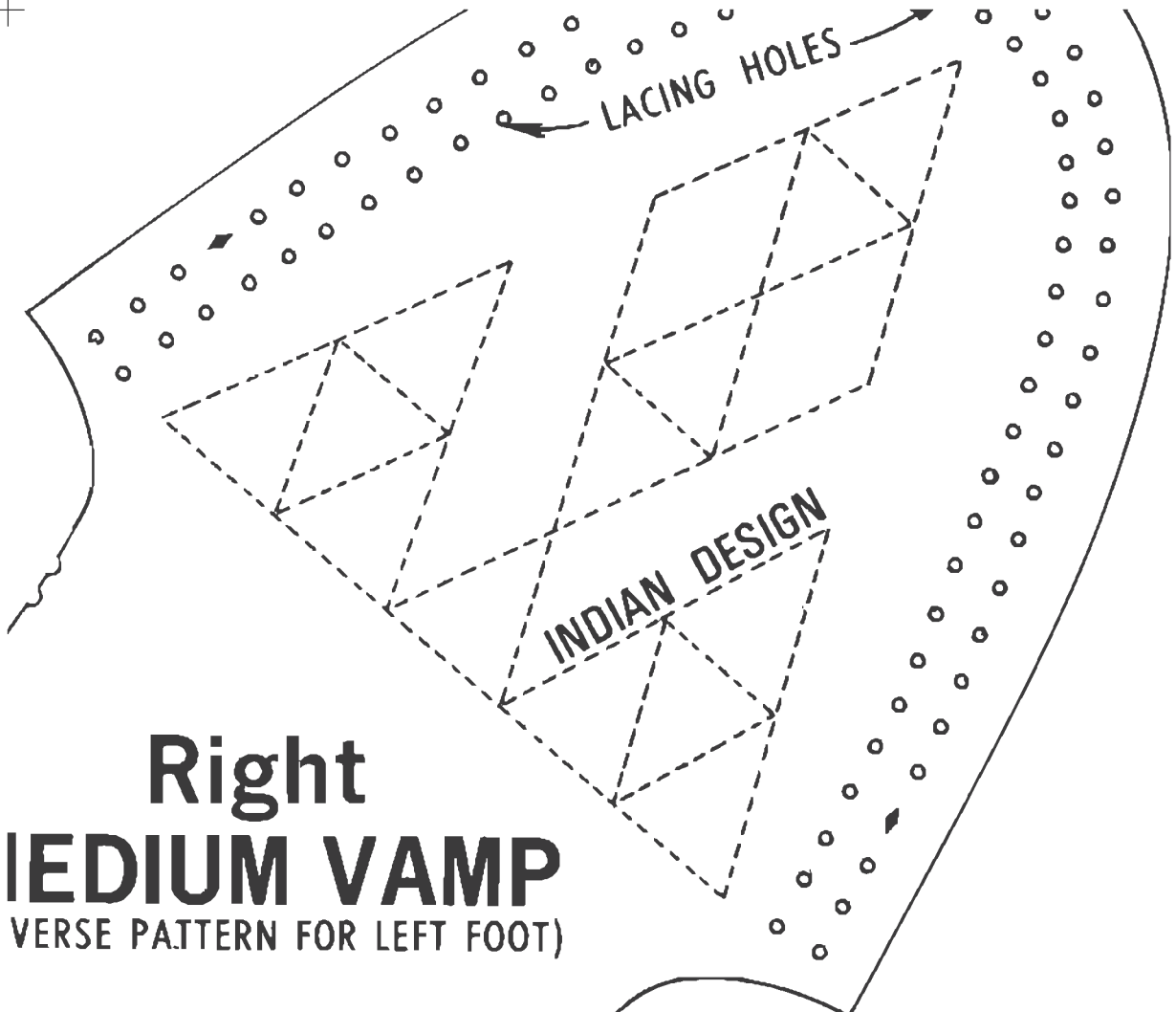

**Right
MEDIUM VAMP**
(REVERSE PATTERN FOR LEFT FOOT)

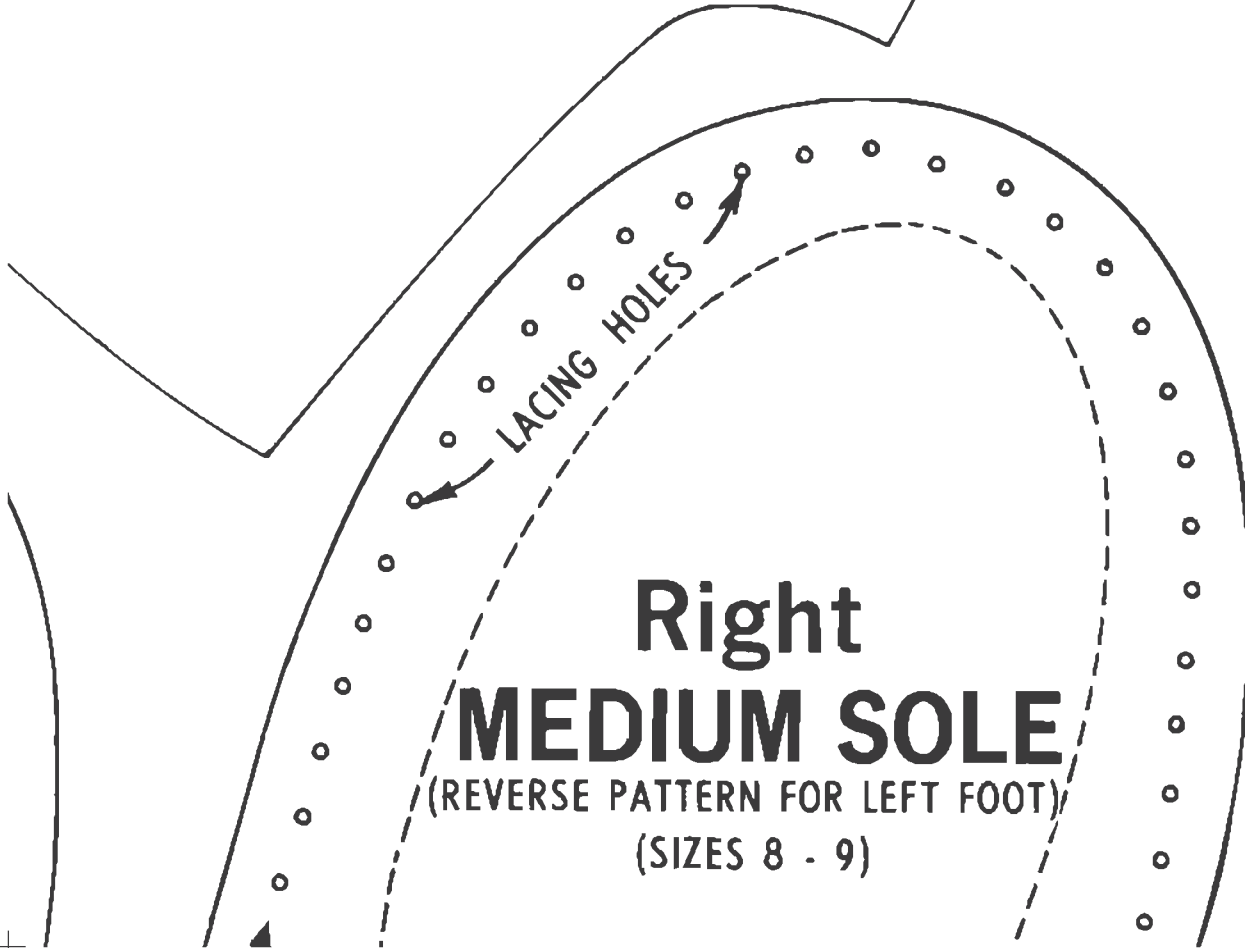

**Right
MEDIUM SOLE**
(REVERSE PATTERN FOR LEFT FOOT)
(SIZES 8 - 9)

DIRECT

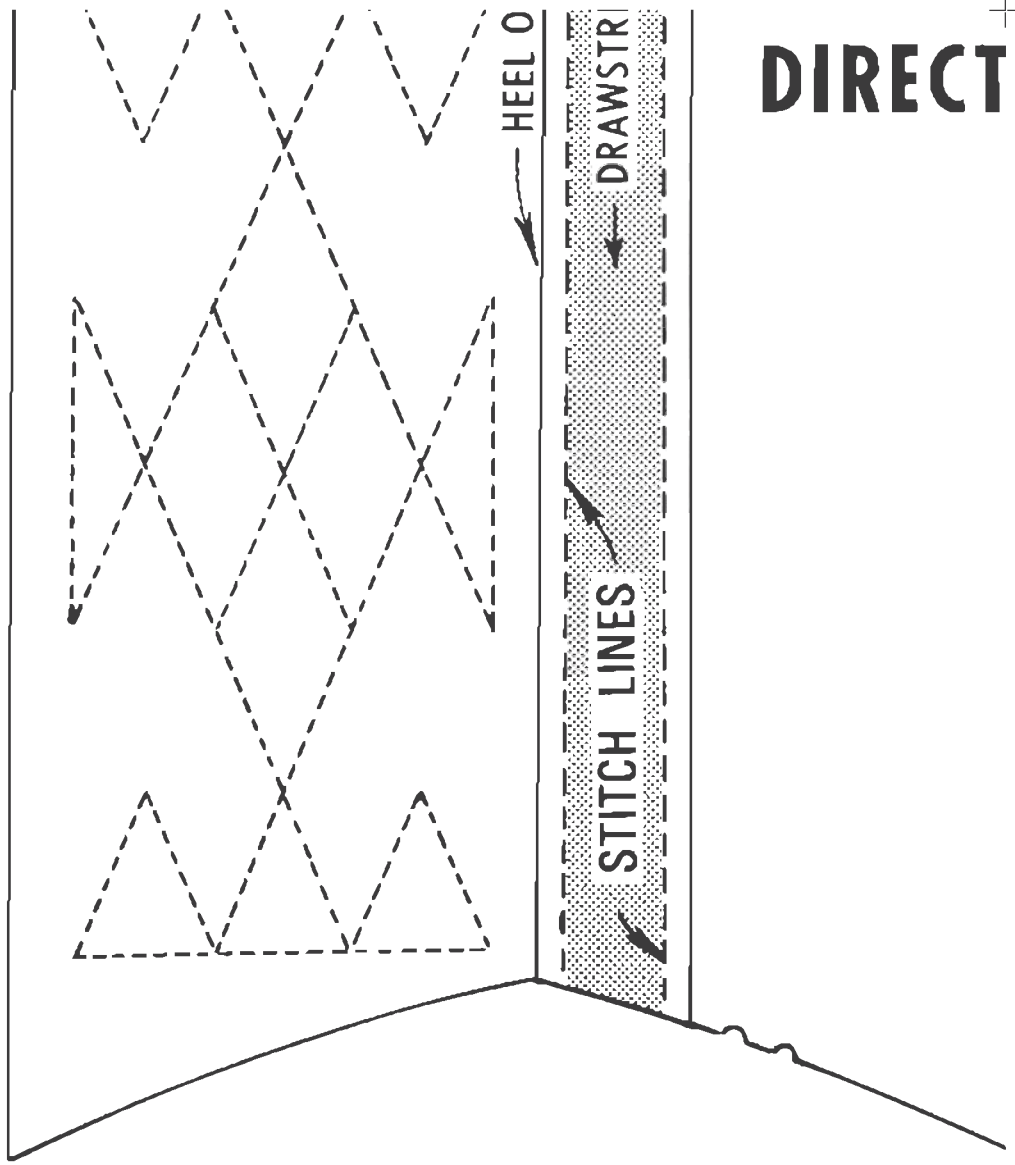

IONS

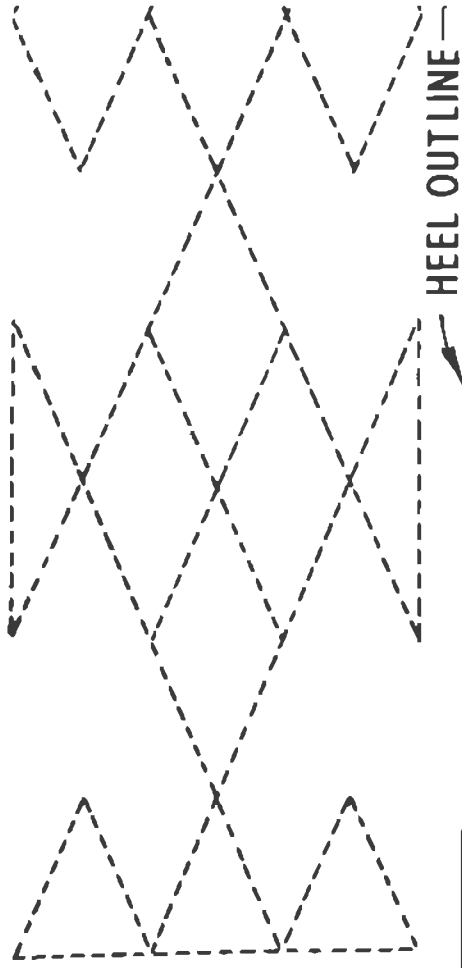
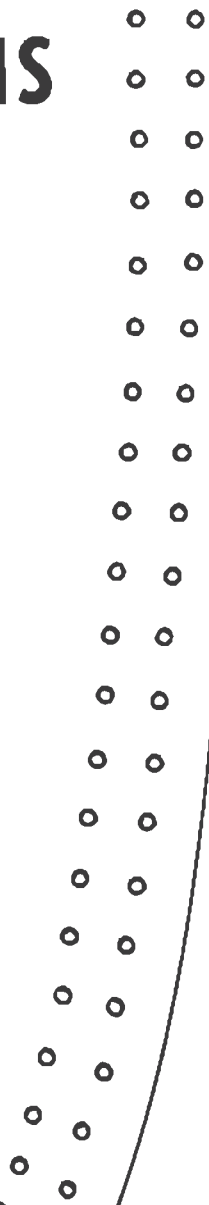

HEEL OUTLINE

DRAWSTR

STITCH LINES

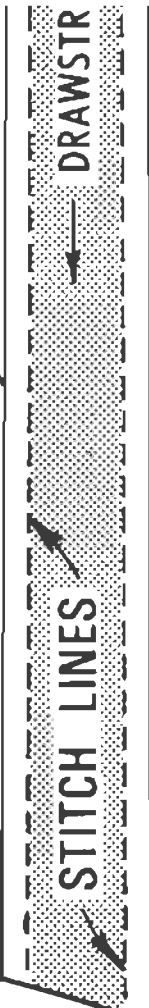

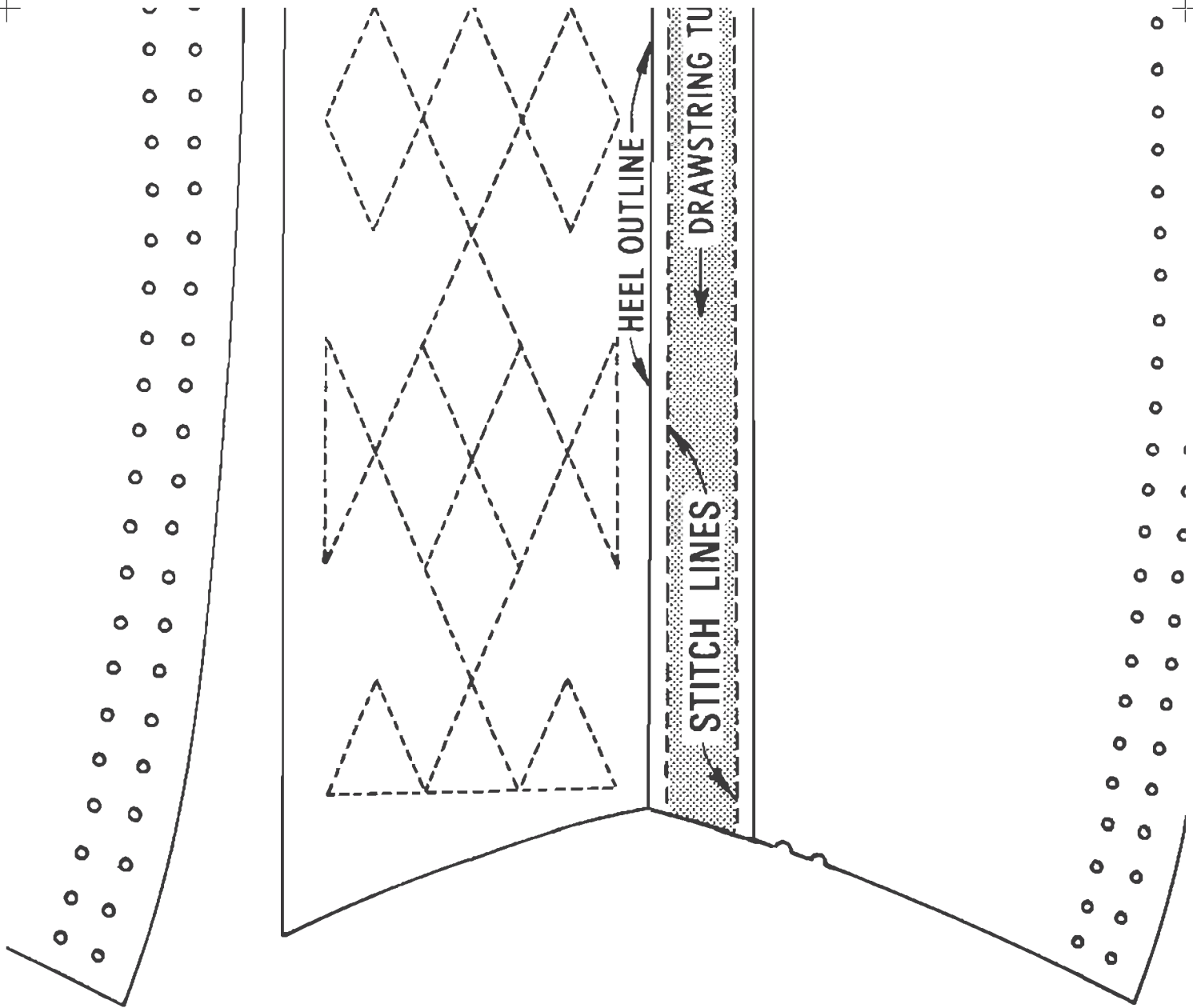

Right
LARGE VAMP
(REVERSE PATTERN FOR LEFT FOOT)

INDIAN DESIGN

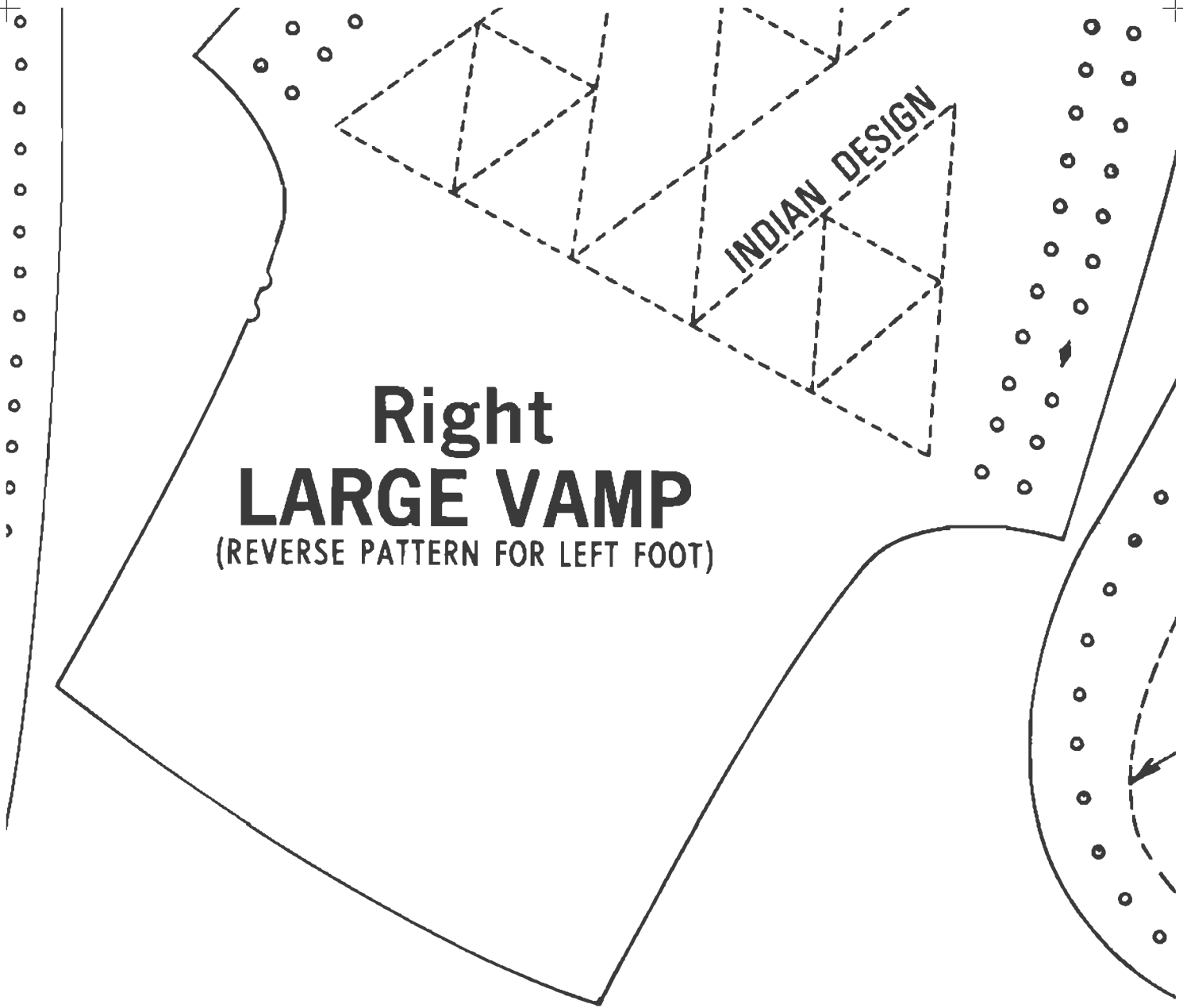

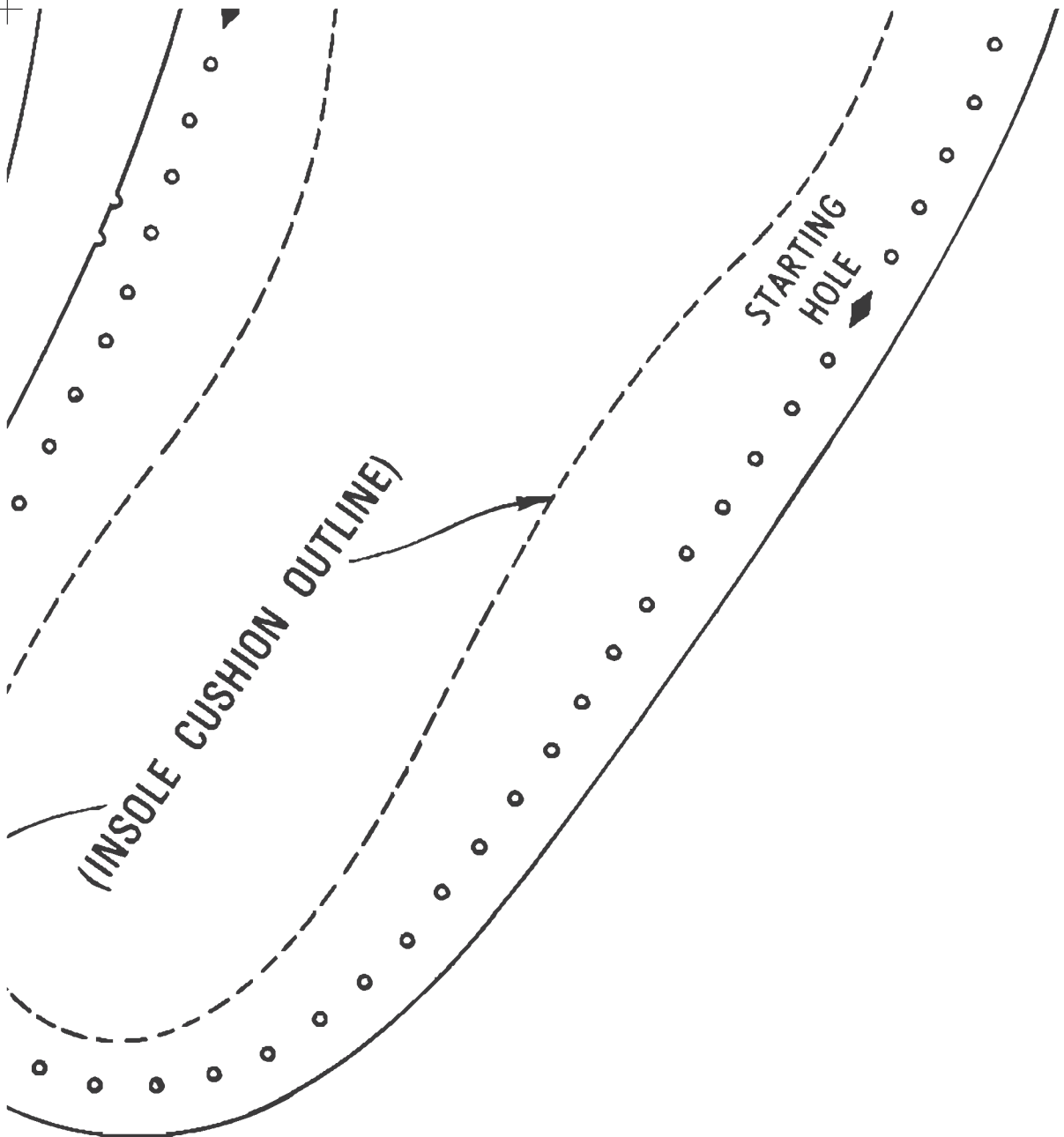

(INSOLE CUSHION OUTLINE)

STARTING HOLE

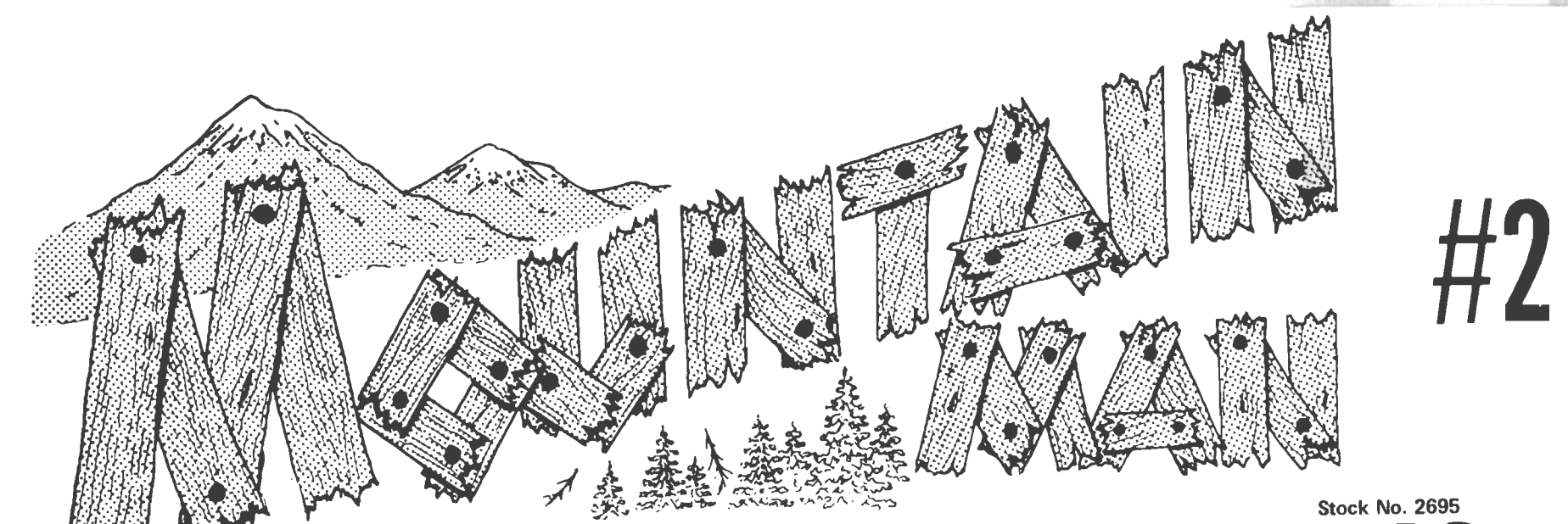

#2

Stock No. 2695

MOCCASIN PATTERNS

by GENE NOLAND

ASSEMBLY INSTRUCTIONS

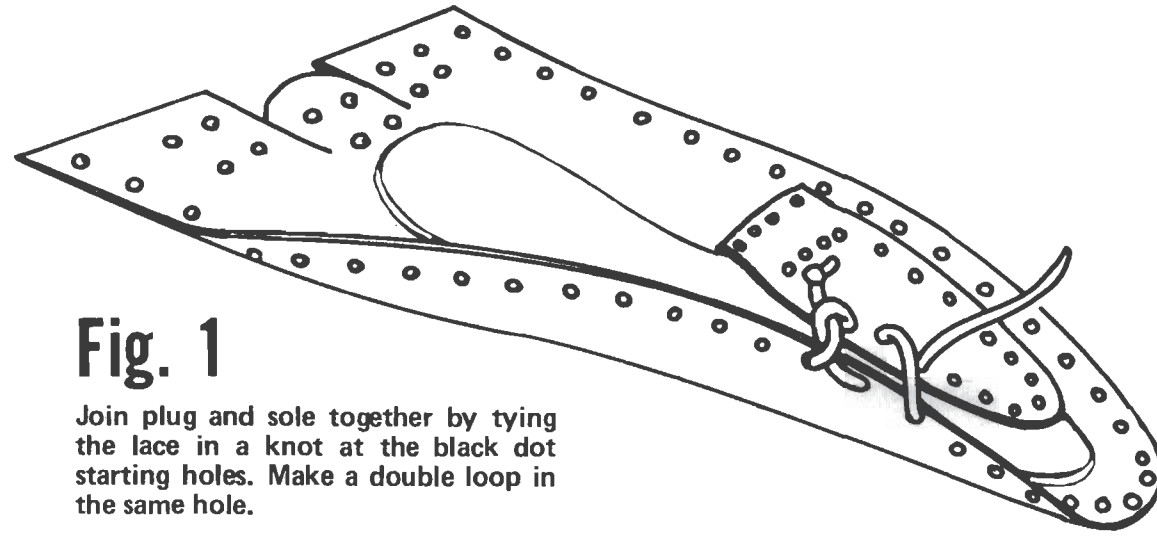

Fig. 1

Join plug and sole together by tying the lace in a knot at the black dot starting holes. Make a double loop in the same hole.

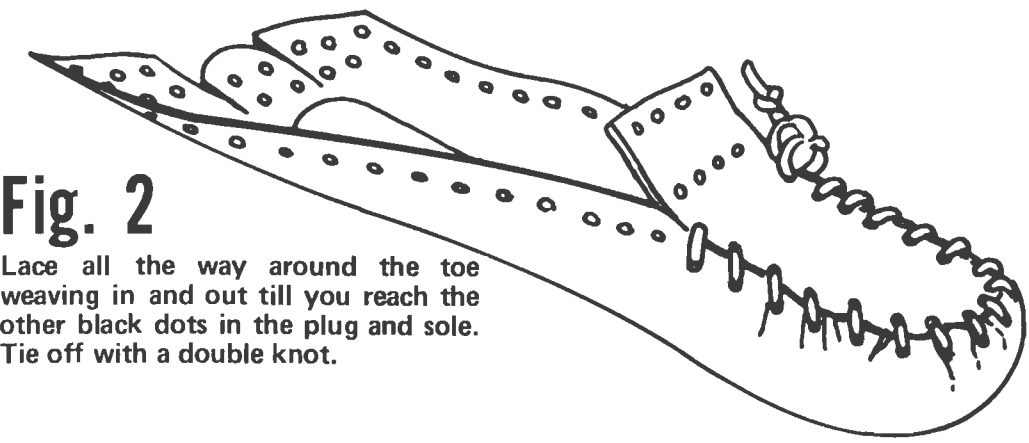

Fig. 2

Lace all the way around the toe weaving in and out till you reach the other black dots in the plug and sole. Tie off with a double knot.

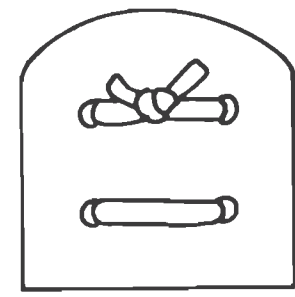

Fig. 3

Lace the heel together as shown by inserting the lace through the top hole. Cross over and come out at the bottom on the opposite side, cross over at the bottom, insert the lace again in the other bottom hole. Cross over and up to the opposite upper hole. Bring the lace to the outside again and there tie off.

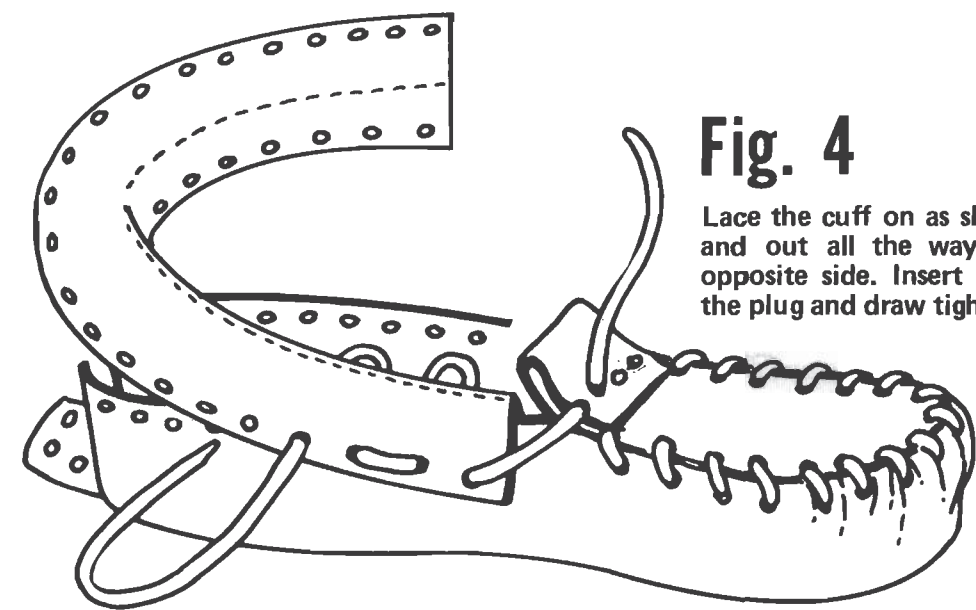

Fig. 4

Lace the cuff on as shown weaving in and out all the way around to the opposite side. Insert the tips through the plug and draw tight and tie.

DIRECTIONS

Choose a good leather for making your moccasins, one that is durable and soft. You may cut your own insoles if you have the foam rubber material or use the one found in the drug store. You might even stitch a heavier sole to the bottom.

Start by cutting out the design and punch all the holes. Add the Indian design or make your own but do this before you begin to lace.

Glue the insole in position on the inside of the sole leather as shown.

In lacing these moccasins the tightness of the lace lacing the plug to the sole will help to determine the size and fit of the moccasin. Check moc on foot occasionally as you lace the moccasin. Remember they can always be retightened if they become too loose.

You can use suede lace or a rawhide lace to lace the moccasin. You will notice that the holes in the soles are wider apart than they are in the plug. In this way it allows the sole leather to gather when laced around the plug.

Start by joining the plug and sole together at the black dot starting holes on the outside of the sole moccasin.

Make a knot and then double loop it through the same hole. Now pull the lace over the plug (from the inside to the outside) and under the sole (from outside to inside), then back up through the plug. Do this all the way around the toe. Use the over and over stitch, pulling the lace tight each time but checking to see if the toes will fit. Tie off at the black dot holes on the other side. See Fig. 2. NOTE: Keep the lace pulled tight as you work but again check each time to see that the toes fit.

Next lace the heel tabs together by starting in the top hole of the bottom heel tab. For the LEFT moccasin the outside heel tab should be over the inside heel tab and the bottom heel tab is over both of them. So start your lacing by going through the top hole in the bottom heel tab, then through the hole in the outside heel tab and through the inside heel tab. Cross over and down to the opposite hole at the bottom and come out reversing the process. Once outside again, cross over to the

other bottom hole and go back through to the inside again. Once inside cross over and up to the other top hole, go through the holes to the outside again and then tie off with a square knot.

Start the lace for the cuff through the plug as shown in Fig. 4, leaving about 6" for tying. Lace the cuff on by starting your lace through the inside hole of the plug and out through the outside hole. Now fold the cuff over and insert the lace through from the outside into the first hole on the cuff and through the first hole on the sole and then through the cuff again on the inside part of the cuff as shown in Fig. 4. Weave in and out till you reach the back part of the heel tabs.

There should be a 4 hole overlap at the heel tabs. Count the holes in the cuff and make sure there are the same number of holes in the sole being laced. When the lacing is complete, come through the plug holes on the opposite side so the lace ends up coming out the inside hole of the plug for tying. Now draw the lace tight to fit the foot and your moccasin is complete. Lace the other one in like manner.

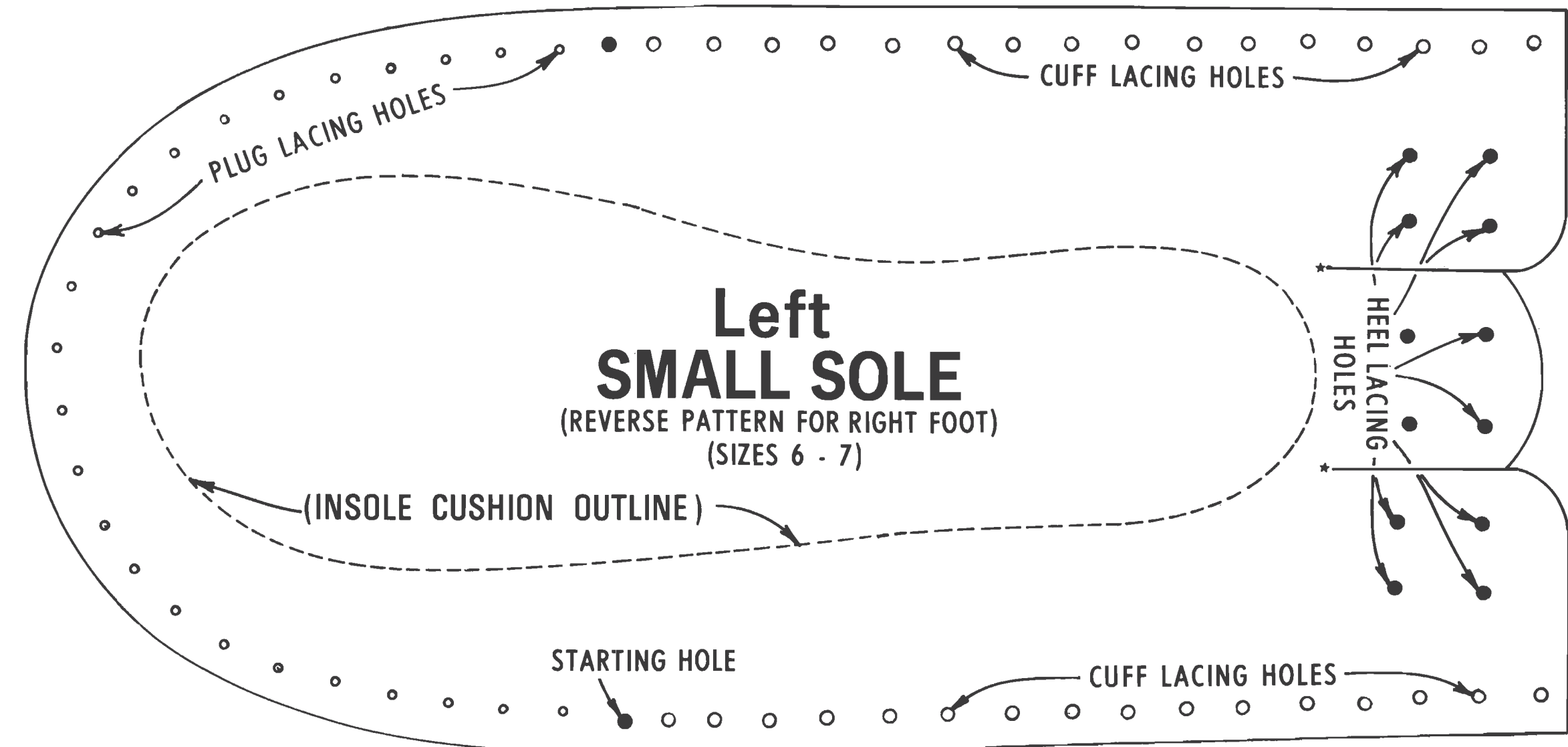
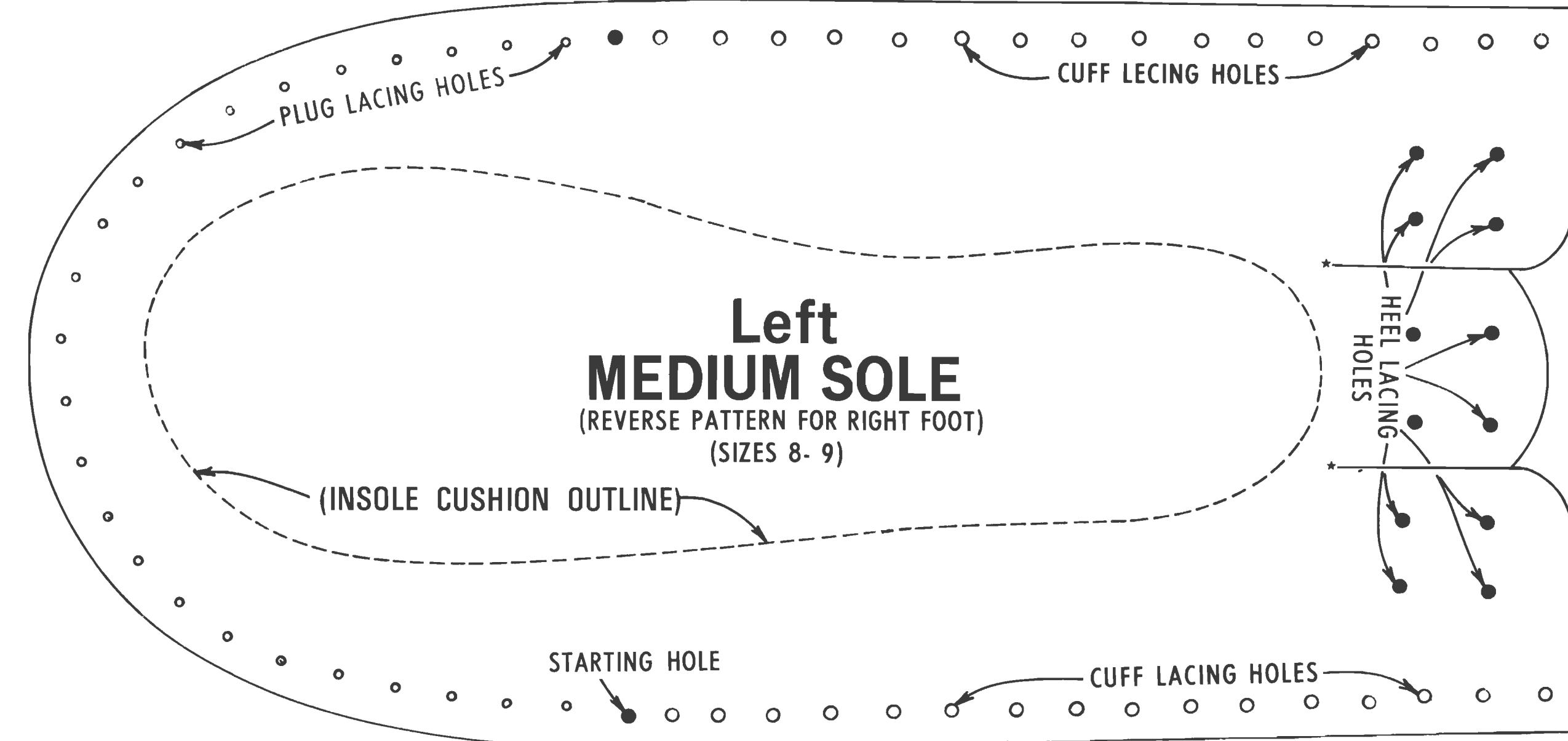
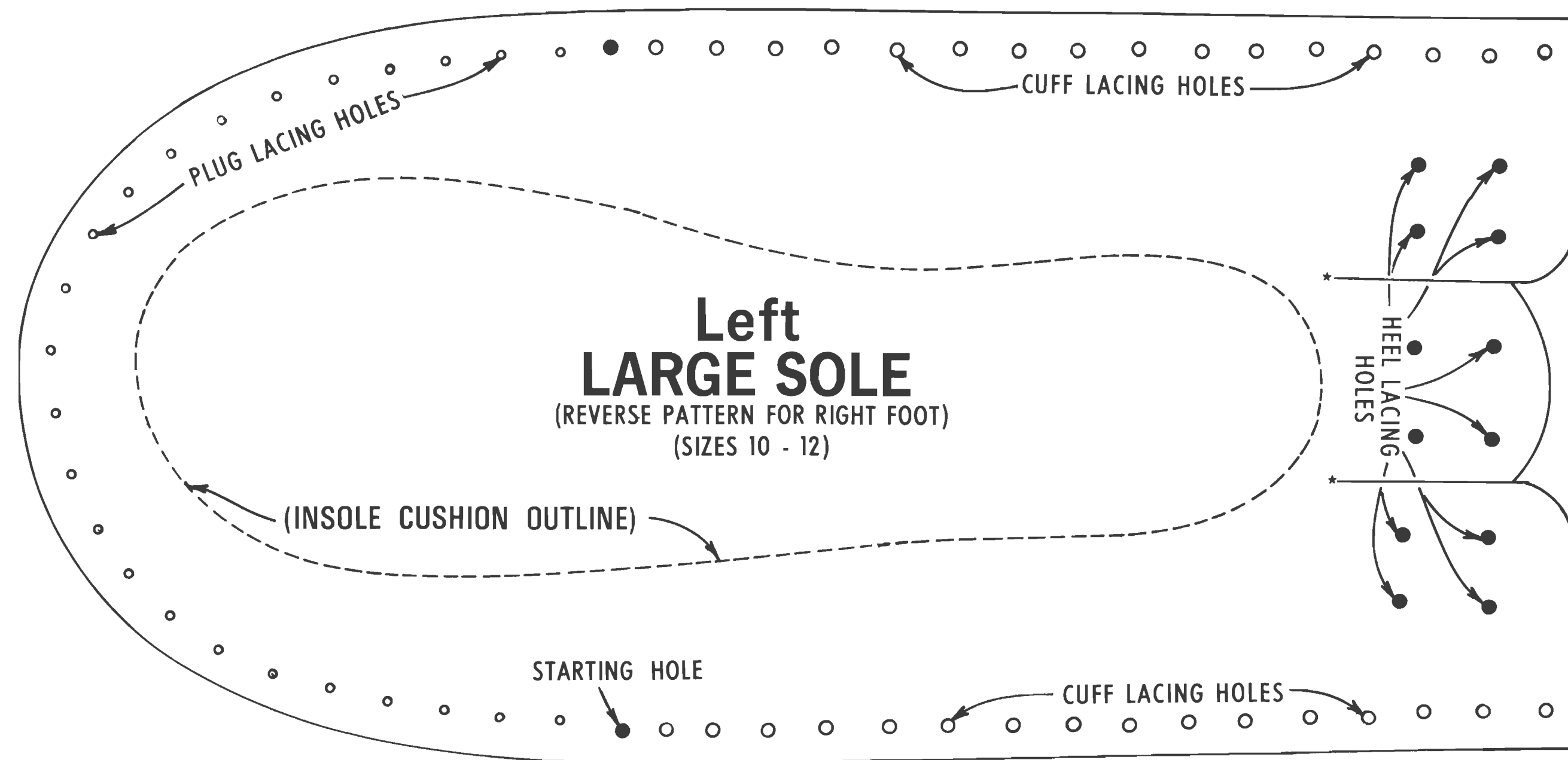
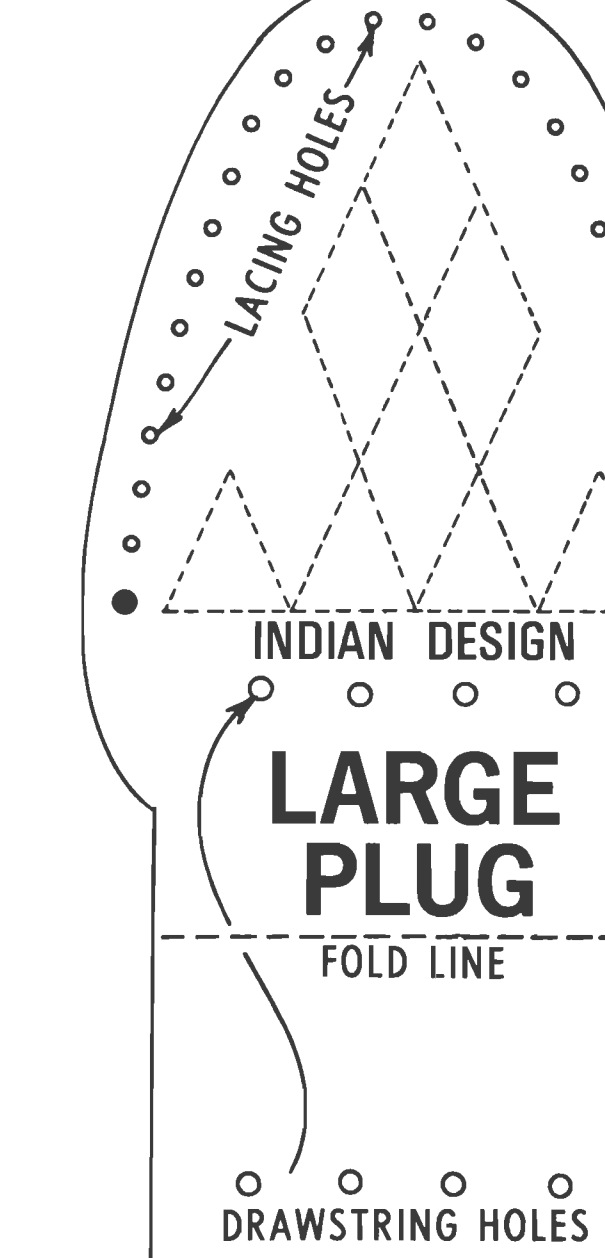
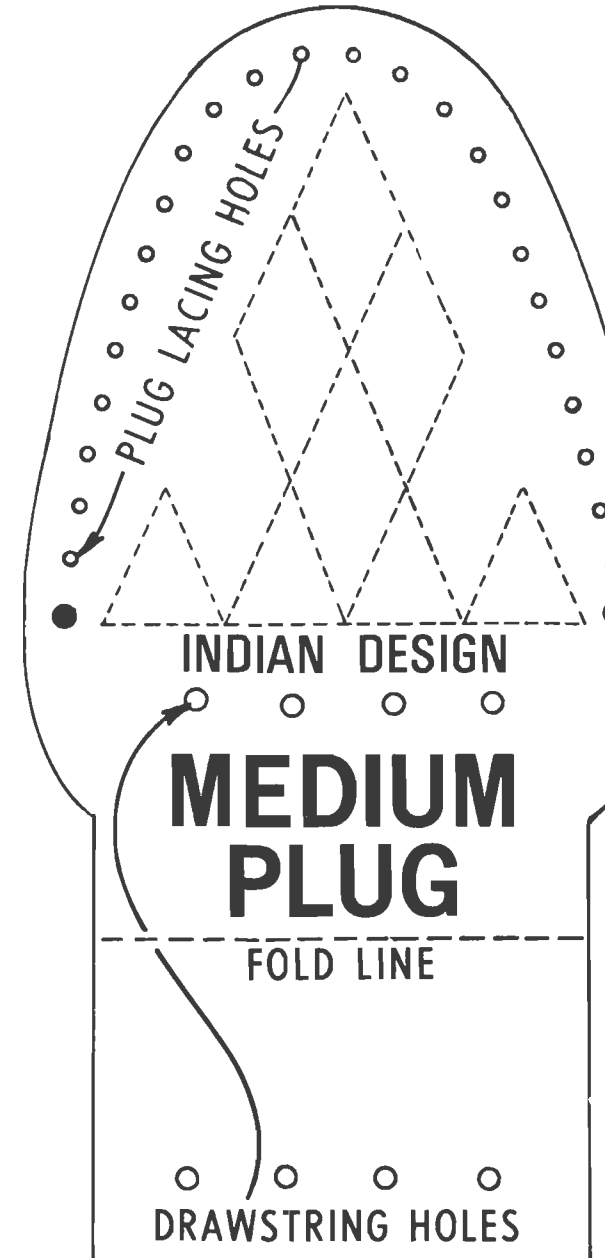
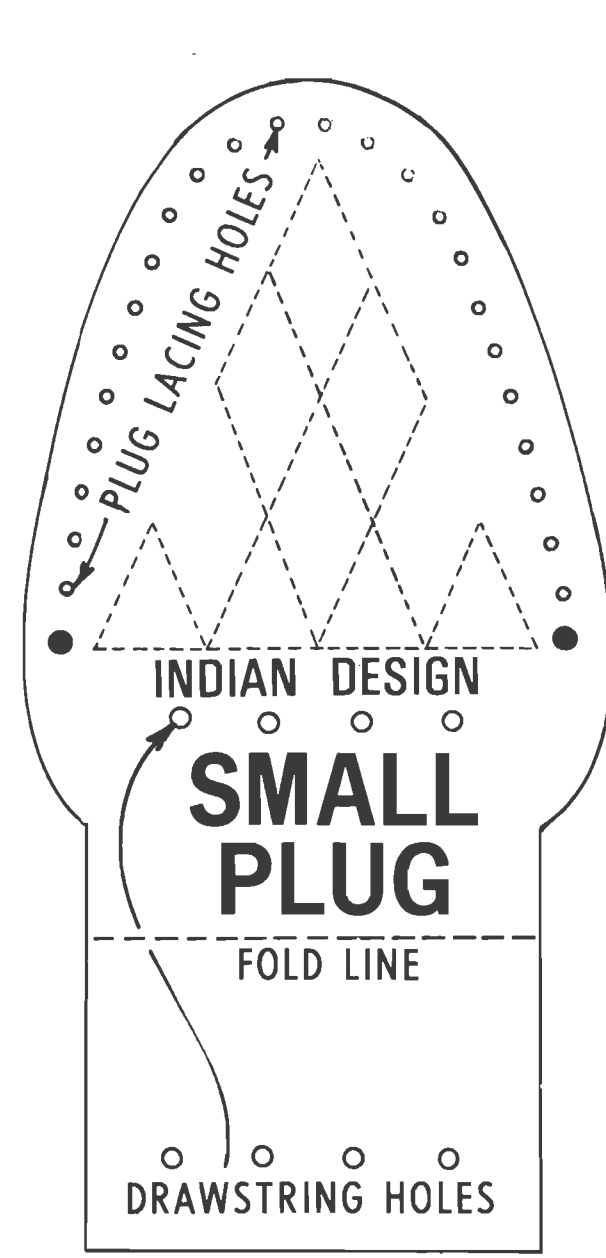
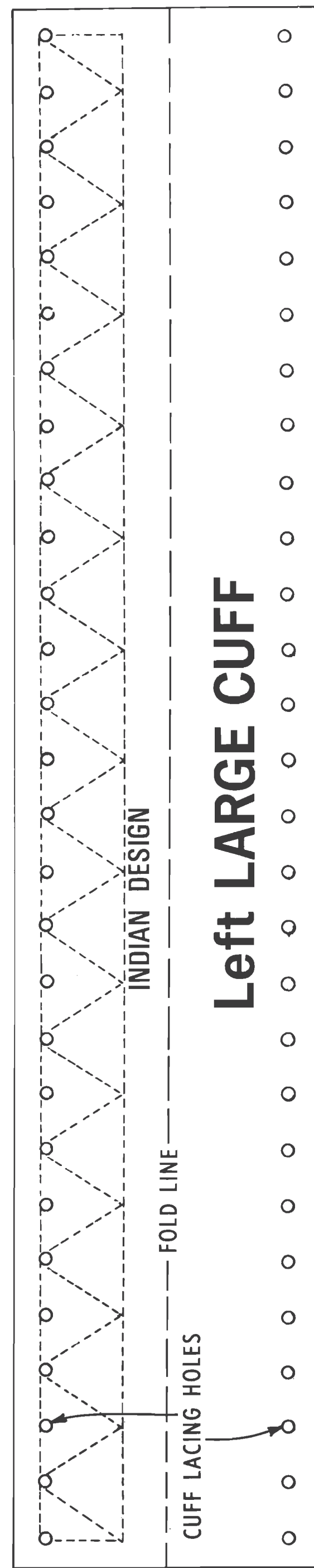
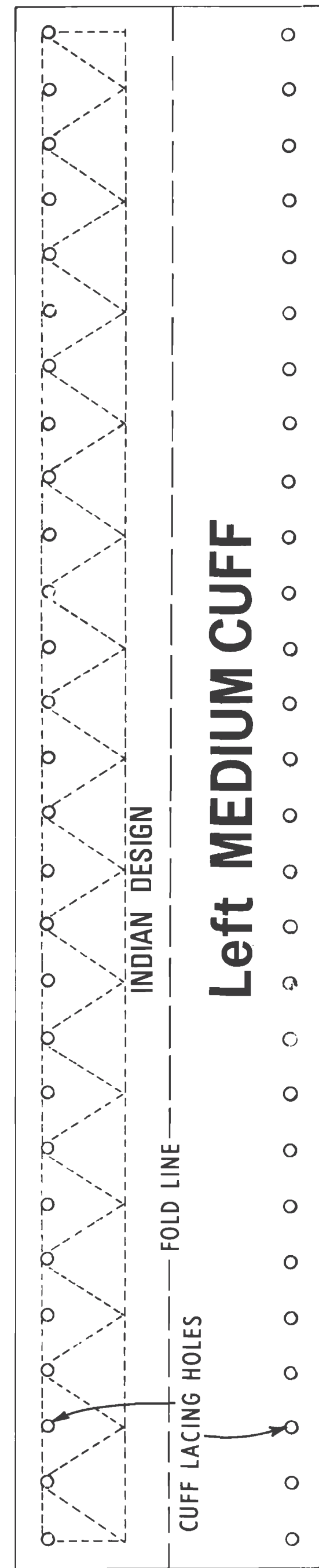
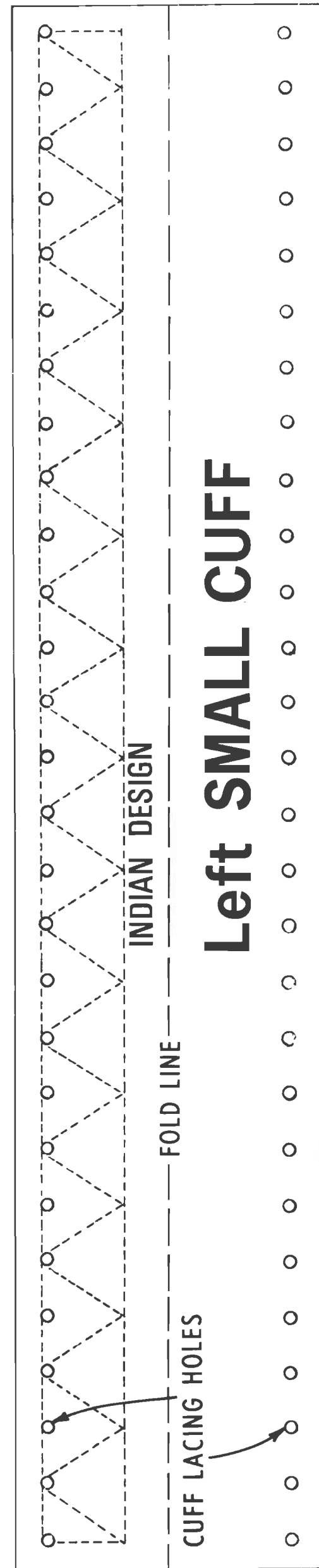

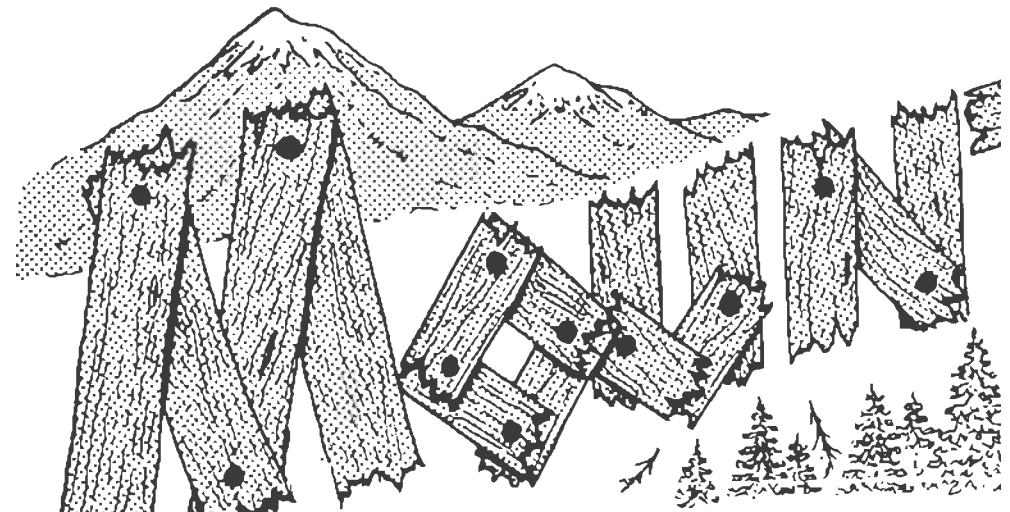

MOCCASIN

by

ASSEMBLY



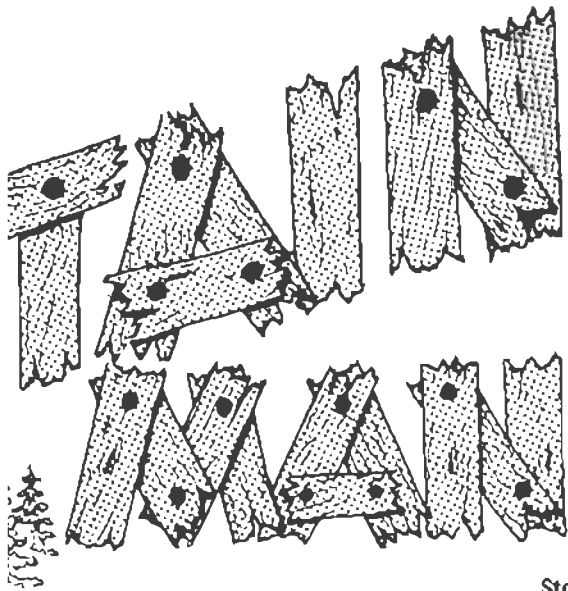

#2

Stock No. 2695

N PATTERNS

GENE NOLAND

Y INSTRUCTIONS

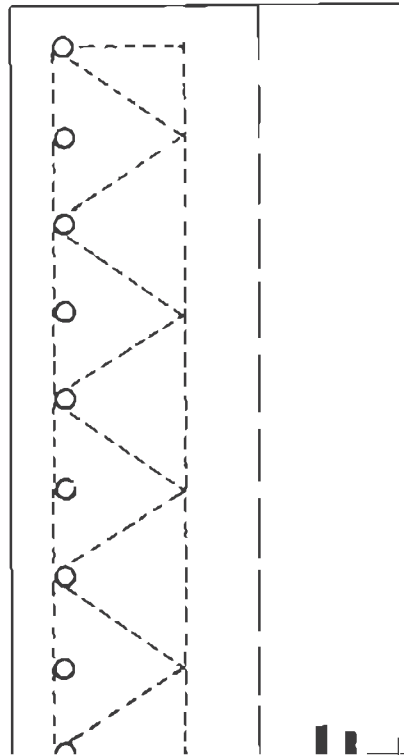

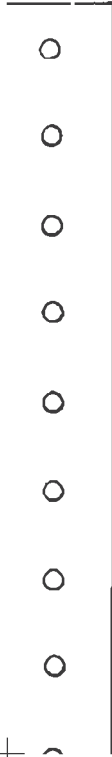

A handwriting practice box for the letter 'F'. It features a dashed outline of the letter 'F' with small circles at the top and bottom of each vertical stroke. Below the box is a dashed horizontal line, and below that is a solid horizontal line. To the right of the box is a large, bold, black letter 'F'. Below the 'F' is a horizontal row of 12 small circles for dot-marker practice.

A handwriting practice box for the letter 'F'. It features a dashed outline of the letter 'F' with small circles at the top and bottom of each vertical stroke. Below the box is a dashed horizontal line, and below that is a solid horizontal line. To the right of the box is a large, bold, black letter 'F'. Below the 'F' is a horizontal row of 12 small circles for dot-marker practice.

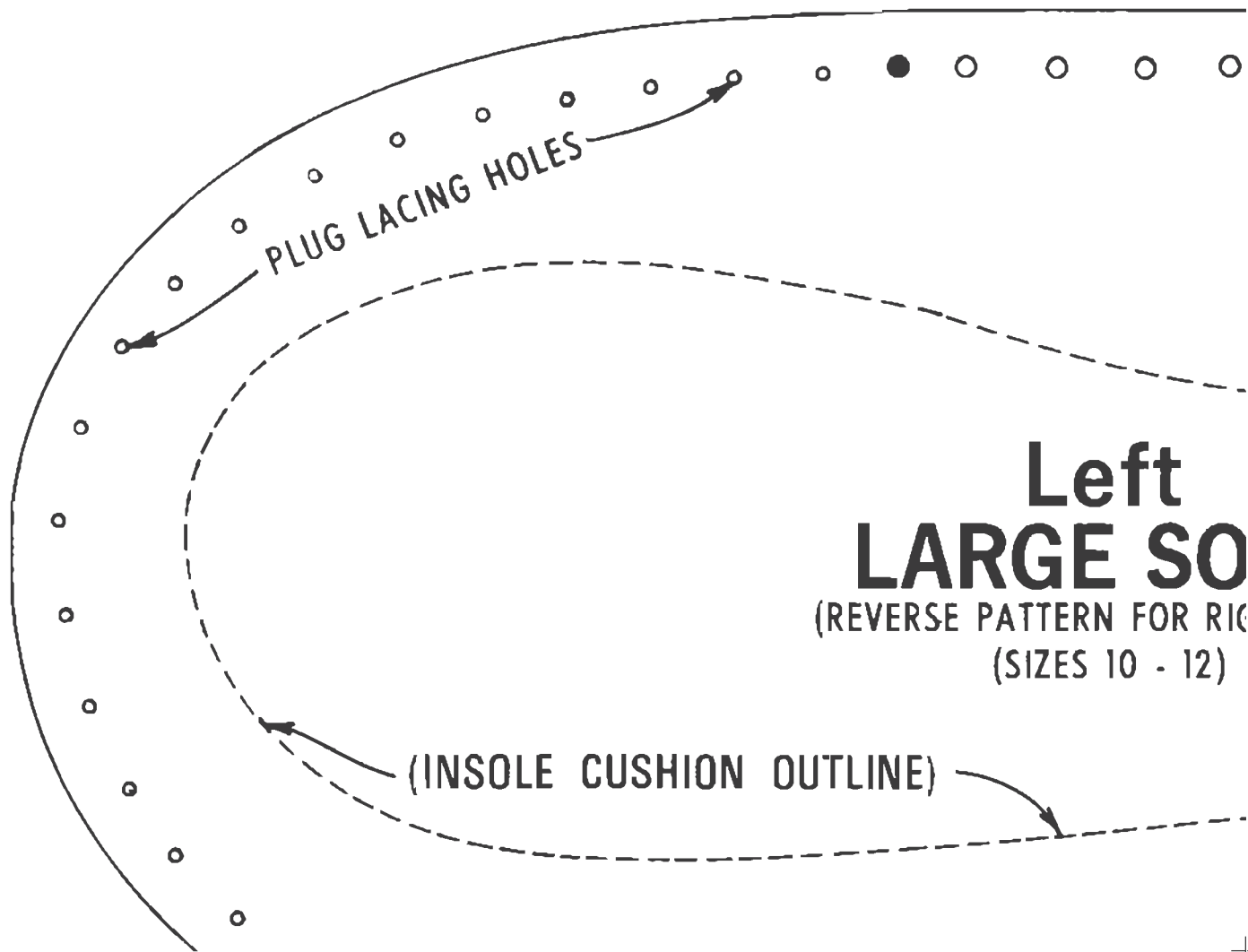

PLUG LACING HOLES

Left
LARGE SO
(REVERSE PATTERN FOR RIGHT)
(SIZES 10 - 12)

(INSOLE CUSHION OUTLINE)

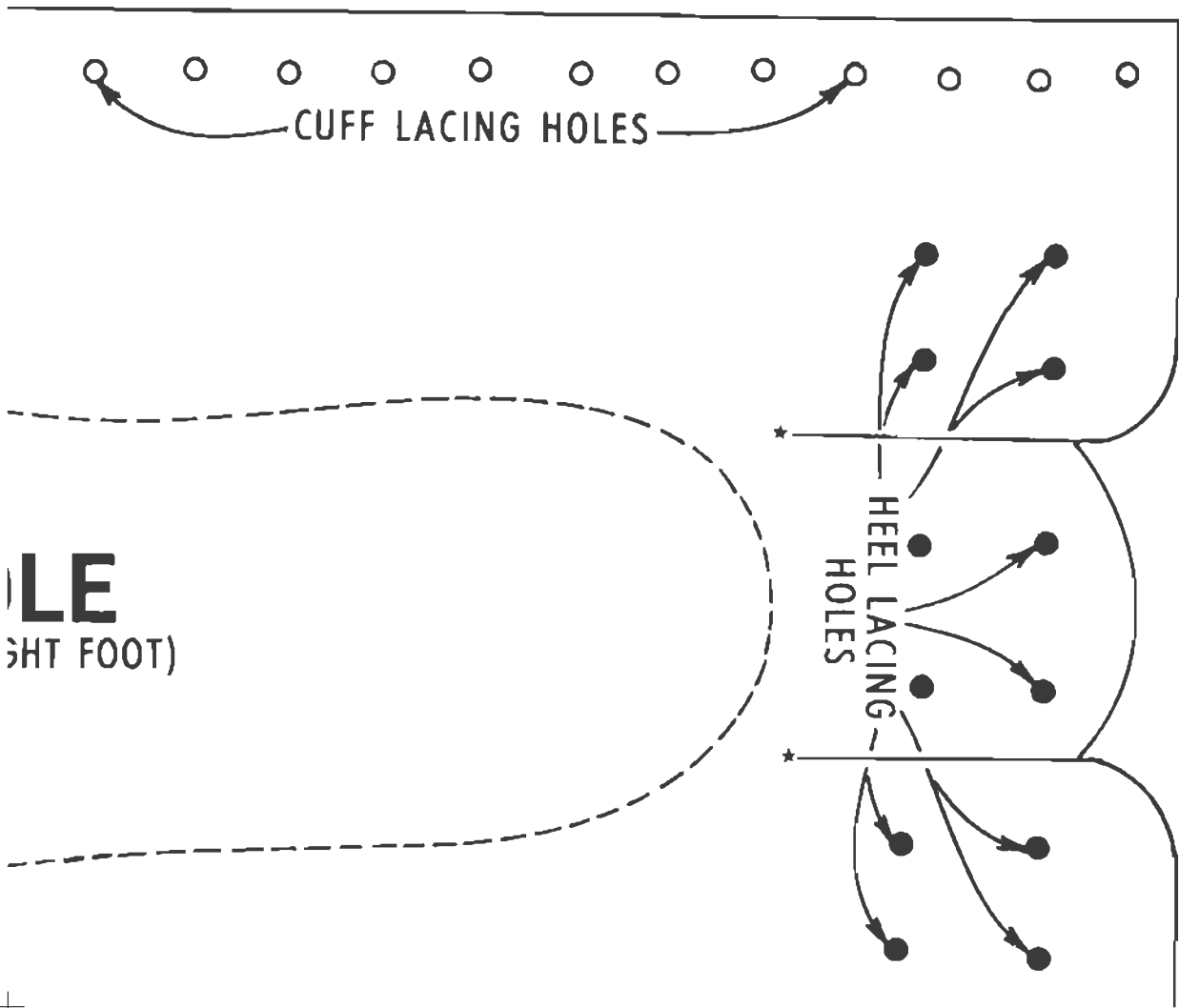

LE
(SHORT FOOT)

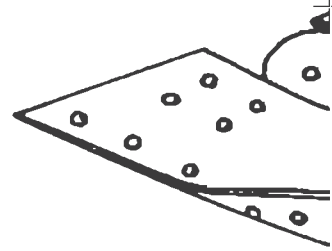

Fig. 1

Join plug and sole the lace in a knot starting holes. Make the same hole.



Fig. 2

Lace all the way around weaving in and out till you other black dots in the plug Tie off with a double knot.

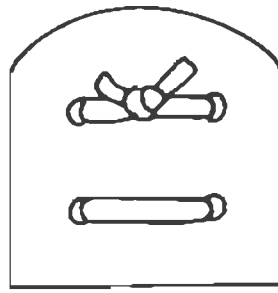
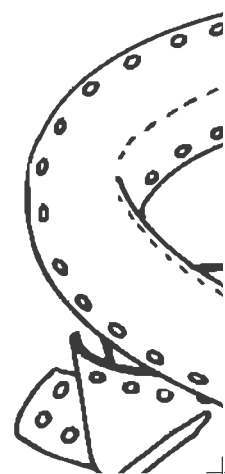
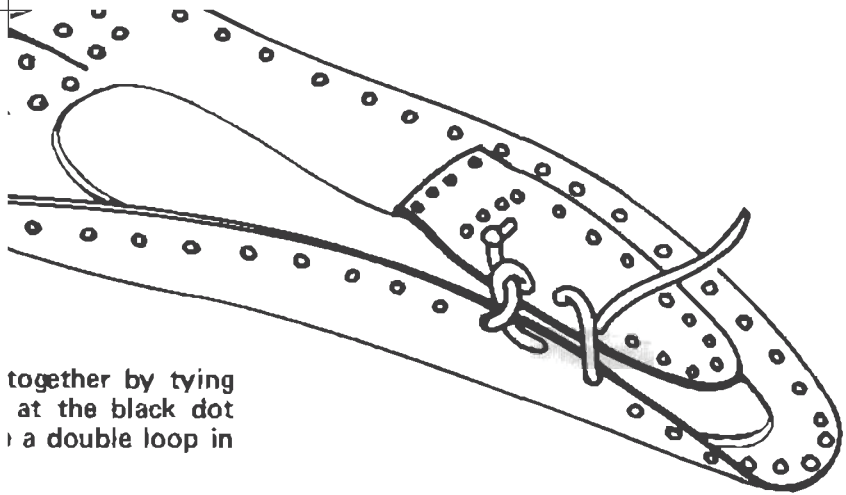

Fig. 3

Lace the heel together as shown by inserting the lace through the top hole. Cross over and come out at the bottom on the opposite side, cross over at the bottom, insert the lace again in the other bottom hole. Cross over and up to the opposite upper hole. Bring the lace to the outside again and there tie off.





together by tying
at the black dot
a double loop in

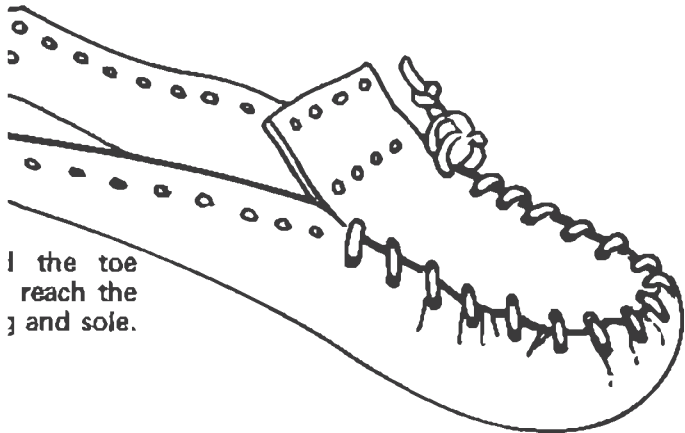

the toe
reach the
and sole.

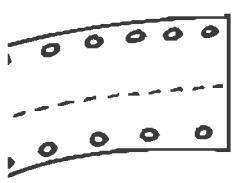
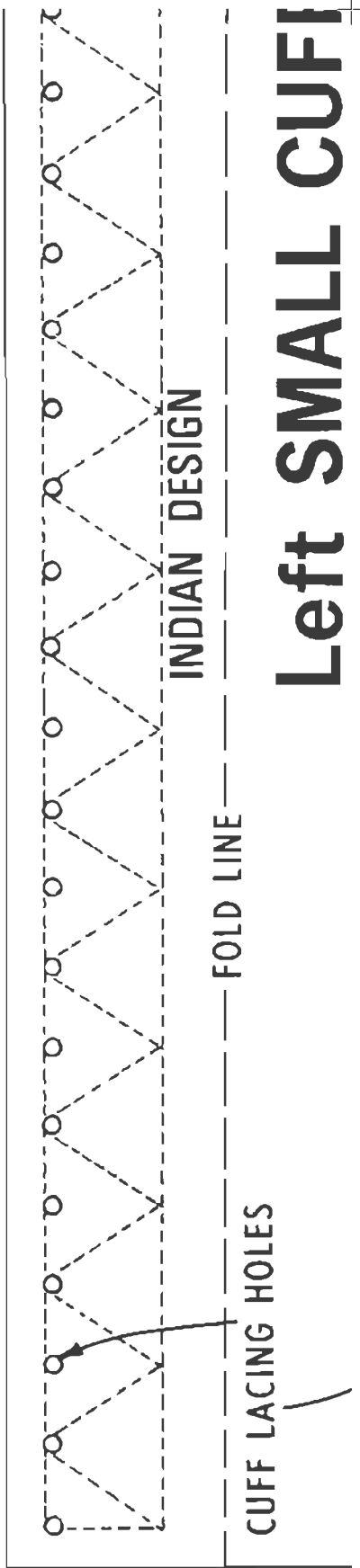

Fig. 4

Lace the cuff on as shown weaving in and out all the way around to the opposite side. Insert the tips through the plug and draw tight and tie.



Left SMALL CUFF



INDIAN DESIGN

FOLD LINE

CUFF LACING HOLES

Left MEDIUM CUF

INDIAN DESIGN

FOLD LINE

CUFF LACING HOLES

Left LARGE CUF

STARTING HOLE



PLUG LACING HOLES



Left
MEDIUM
(REVERSE PATTERN FOR
(SIZES 8-

(INSOLE CUSHION OUTLINE)



STARTING HOLE



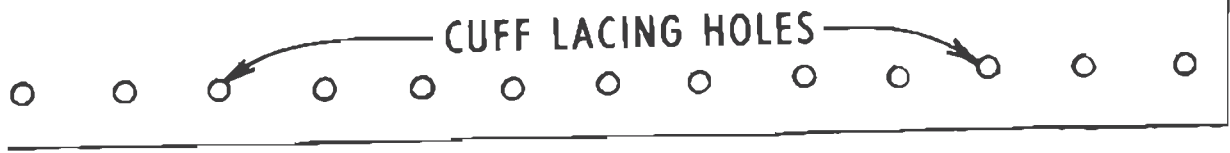



DIRE

Choose a good leather for making your moccasins, one that is durable and soft. You may cut your own insoles if you have the foam rubber material or use the one found in the drug store. You might even stitch a heavier sole to the bottom.

Start by cutting out the design and punch all the holes. Add the Indian design or make your own but do this before you begin to lace.

Glue the insole in position on the inside of the sole leather as shown.

In lacing these moccasins the tightness of the lace lacing the plug to the sole will help to determine the size and fit of the moccasin. Check moc on foot occasionally as you lace the moccasin. Remember they can always be retightened if they become too loose.

You can use suede lace or a rawhide lace to lace the moccasin. You will notice that the holes in the soles are wider apart than they are in the plug. In this way it allows the sole leather to gather when laced around the plug.

Start by joining the
the black dot start
the sole moccasin.

Make a knot and t
the same hole. Now
(from the inside to
sole (from outside
through the plug. I
the toe. Use the o
the lace tight each
the toes will fit. Ti
on the other side. S
lace pulled tight as
each time to see th

Next lace the heel
the top hole of the
LEFT moccasin th
be over the inside
heel tab is over b
lacing by going th
bottom heel tab, t
outside heel tab a
tab. Cross over and
at the bottom an
process. Once outs

CTIONS

the plug and sole together at the lacing holes on the outside of

then double loop it through and pull the lace over the plug (the outside) and under the sole (to inside), then back up to the top hole. Do this all the way around the shoe but checking to see if the lace is tight. Tie off at the black dot holes (see Fig. 2). NOTE: Keep the lacing tight as you work but again check at the toes fit.

the heel tabs together by starting in the bottom heel tab. For the outside heel tab should be the same as the bottom hole of them. So start your lacing through the top hole in the heel tab and through the inside heel tab down to the opposite hole and come out reversing the lacing again, cross over to the

other bottom hole and go back through to the inside again. Once inside cross over and up to the other top hole, go through the holes to the outside again and then tie off with a square knot.

Start the lace for the cuff through the plug as shown in Fig. 4, leaving about 6" for tying. Lace the cuff on by starting your lace through the inside hole of the plug and out through the outside hole. Now fold the cuff over and insert the lace through from the outside into the first hole on the cuff and through the first hole on the sole and then through the cuff again on the inside part of the cuff as shown in Fig. 4. Weave in and out till you reach the back part of the heel tabs.

There should be a 4 hole overlap at the heel tabs. Count the holes in the cuff and make sure there are the same number of holes in the sole being laced. When the lacing is complete, come through the plug holes on the opposite side so the lace ends up coming out the inside hole of the plug for tying. Now draw the lace tight to fit the foot and your moccasin in complete. Lace the other one in like manner.

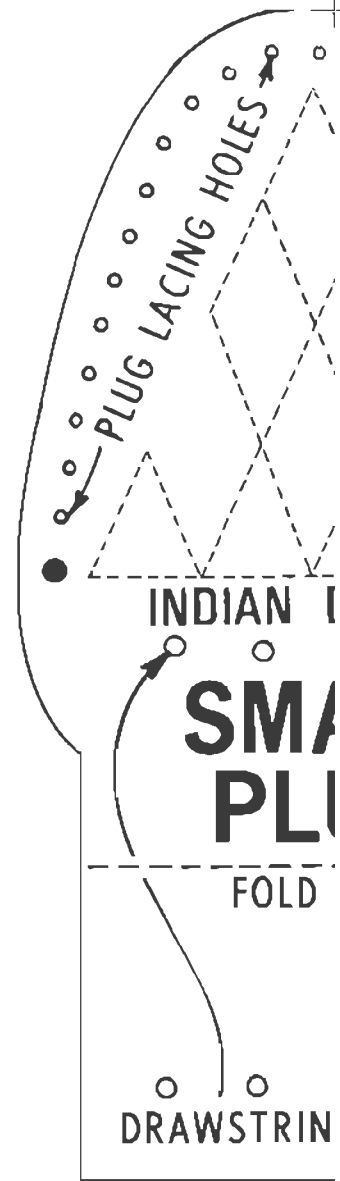

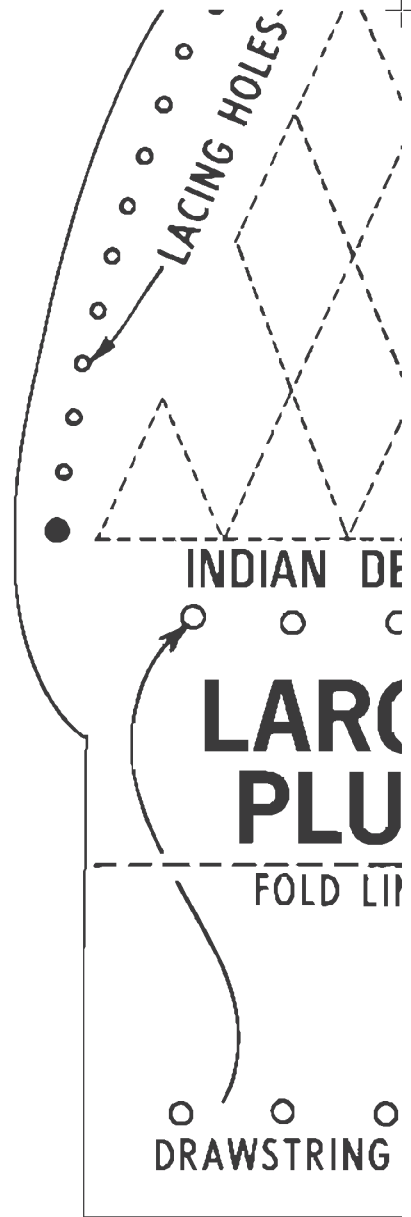
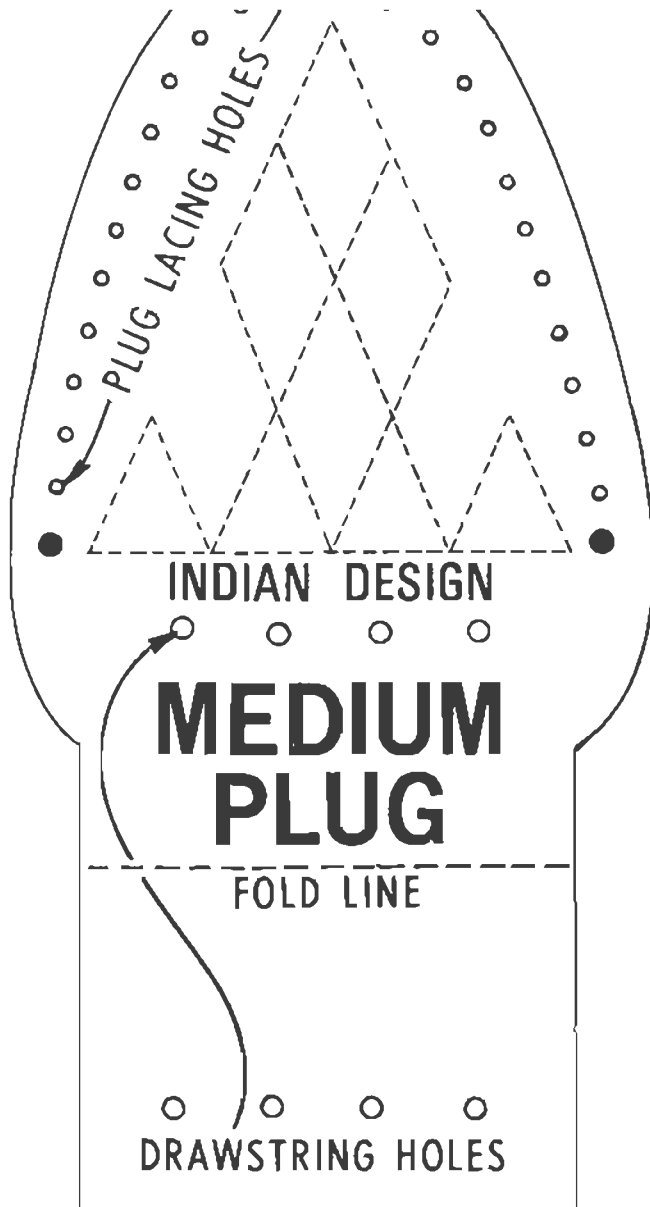
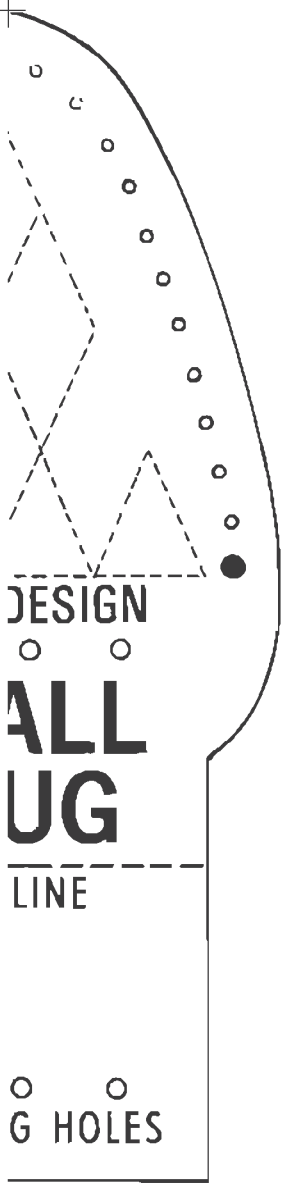

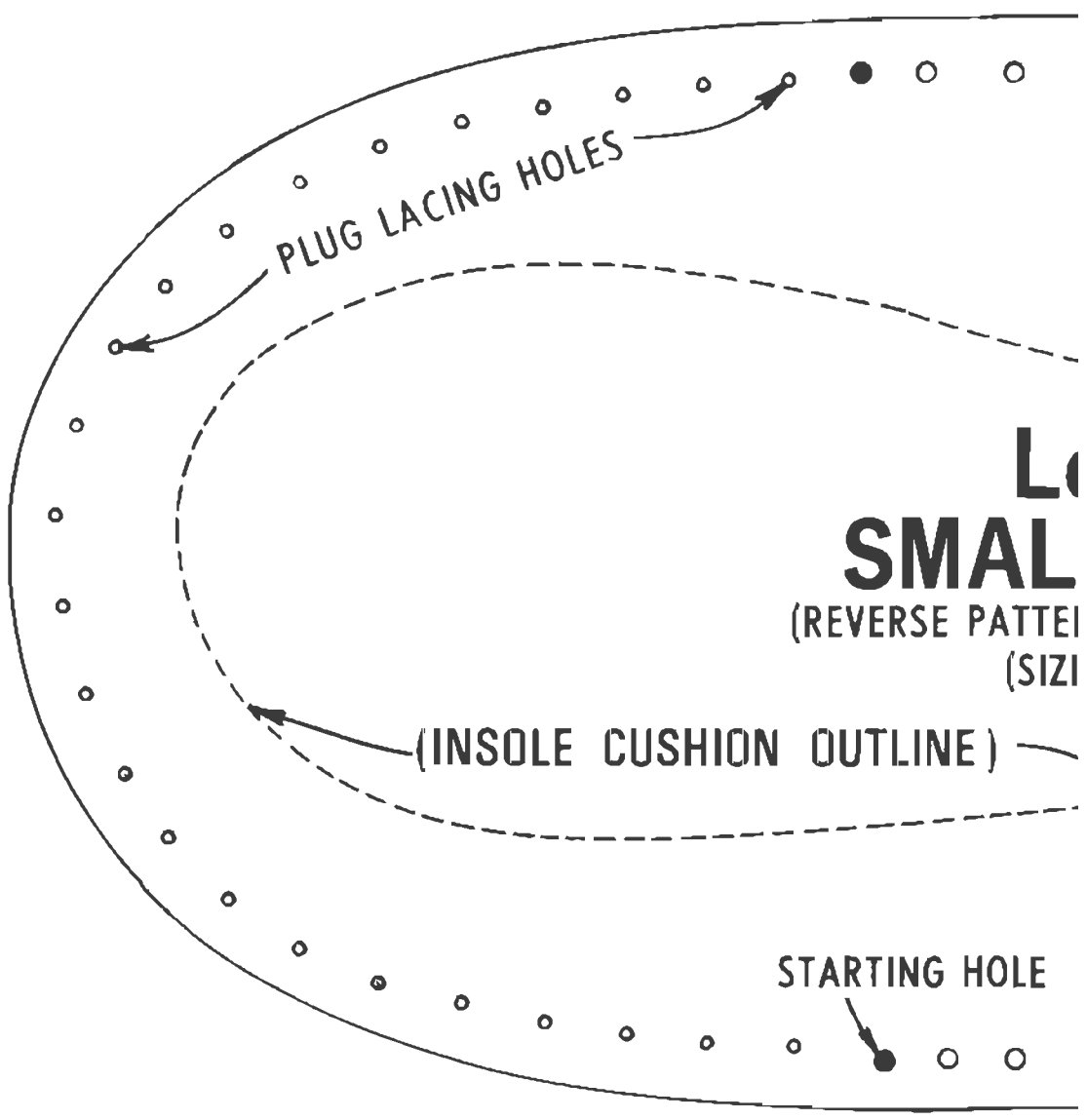
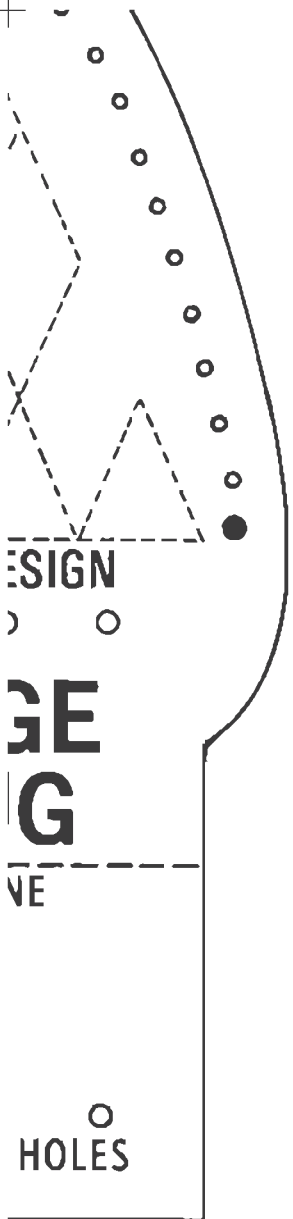

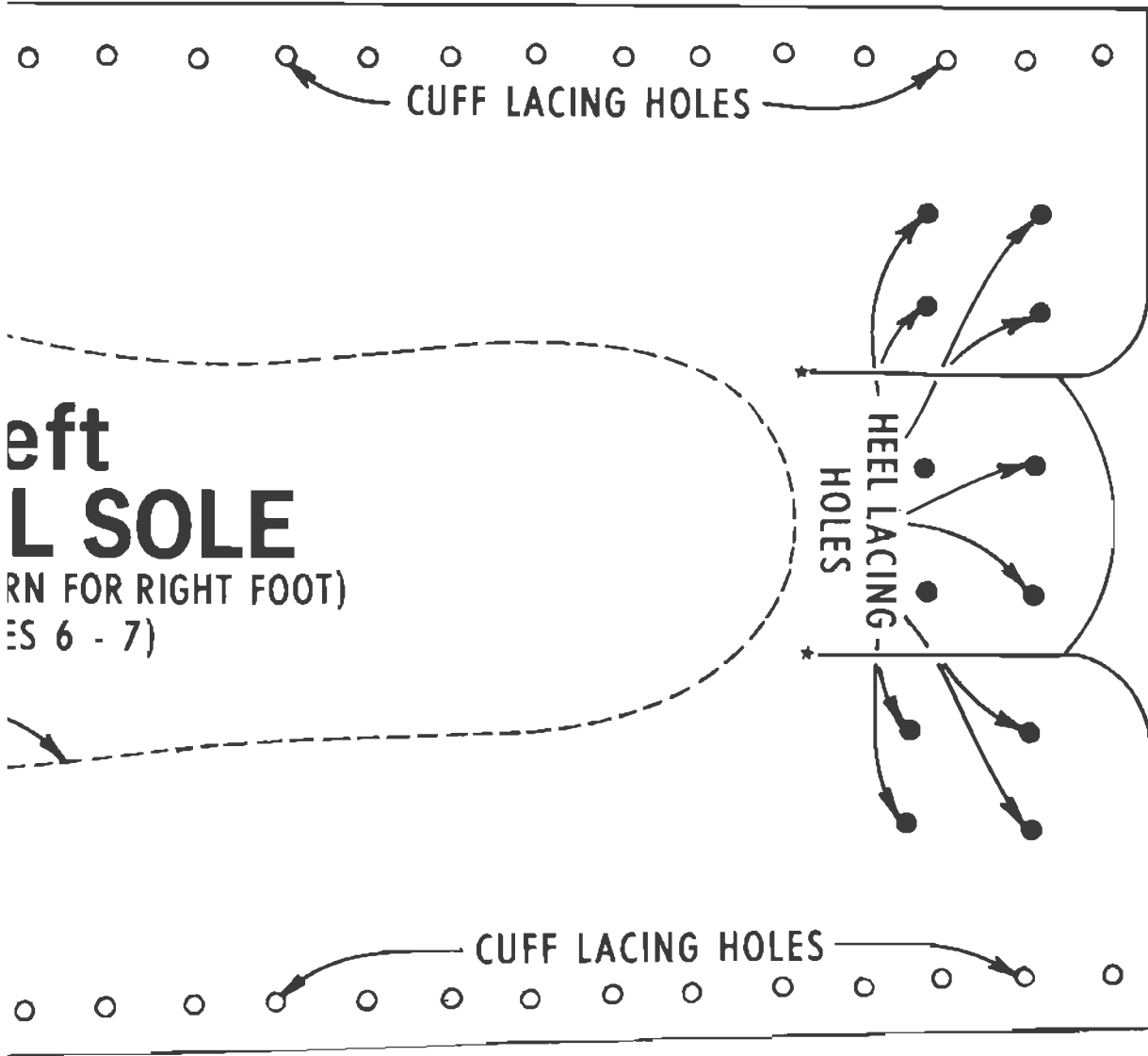

Left
SOLE
(TURN FOR RIGHT FOOT)
(SIZES 6 - 7)

CUFF LACING HOLES

HEEL LACING HOLES

CUFF LACING HOLES

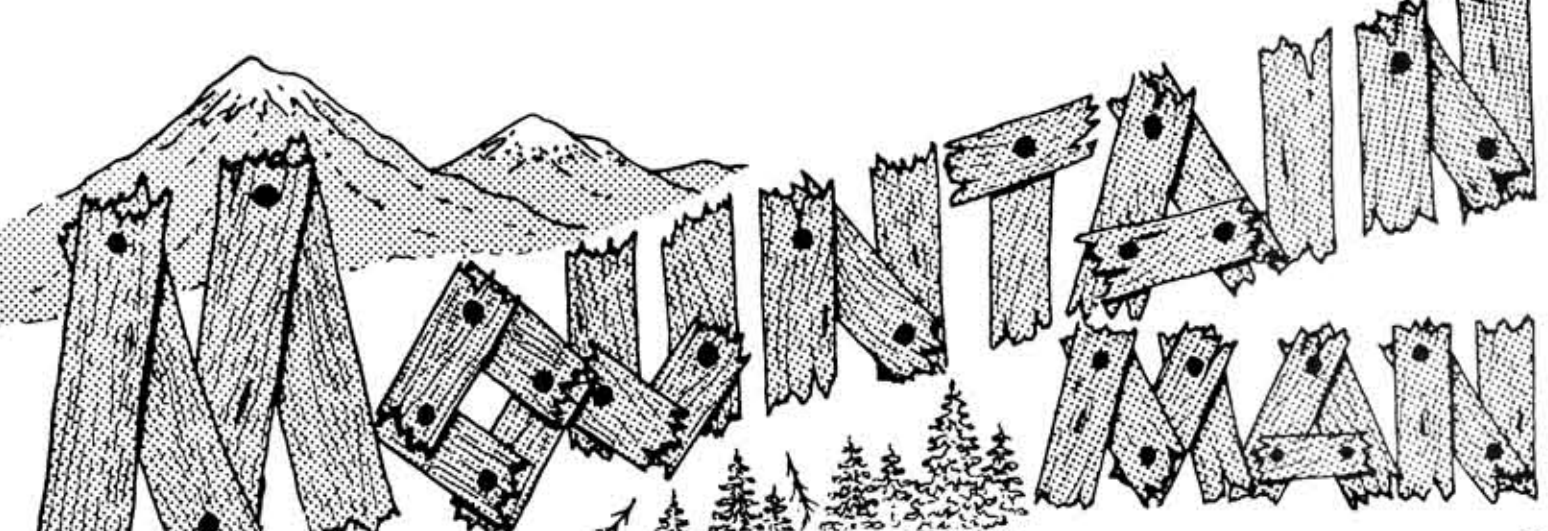

MOCCASIN PATTERNS

by GENE NOLAND

Stock No. 2695



Needle Threading Instructions

Step 1. Push end of thread through needle eye about 1/2".

Step 2. Pierce thread with needle point as shown.

Step 3. Push thread upon needle to eye. Pull end of thread through eye as far as it will go. Hold needle and pull thread over eye to lock end of thread.

#3

ASSEMBLY INSTRUCTIONS

Fig. 1

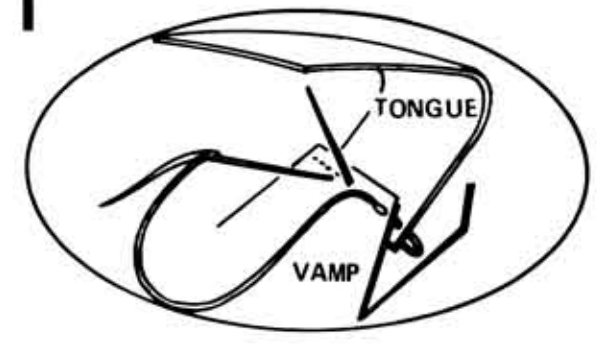

With a saddle stitch, stitch the tongue to the vamp. Place the tongue leather under or on the inside of the vamp.

Fig. 2

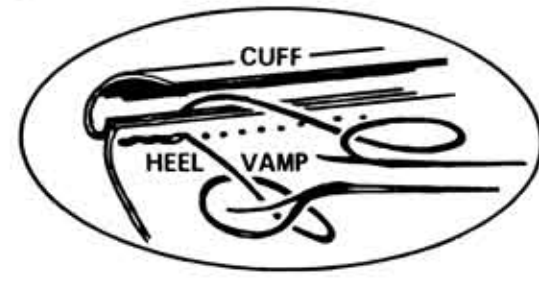

Stitch the cuff on the vamp, starting at the top edge and stitch all the way across with the saddle stitch.

Fig. 3

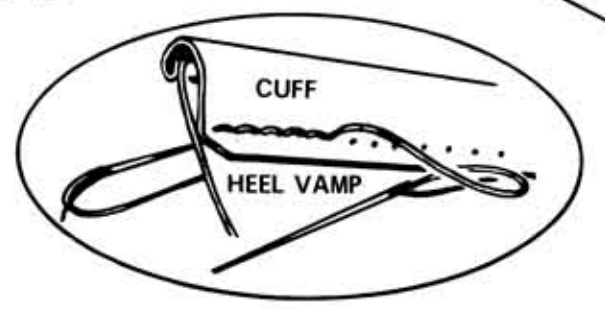

Now fold the cuff over and down on the outside and stitch across to form a drawstring tunnel. Do this with a saddle stitch.

Fig. 4

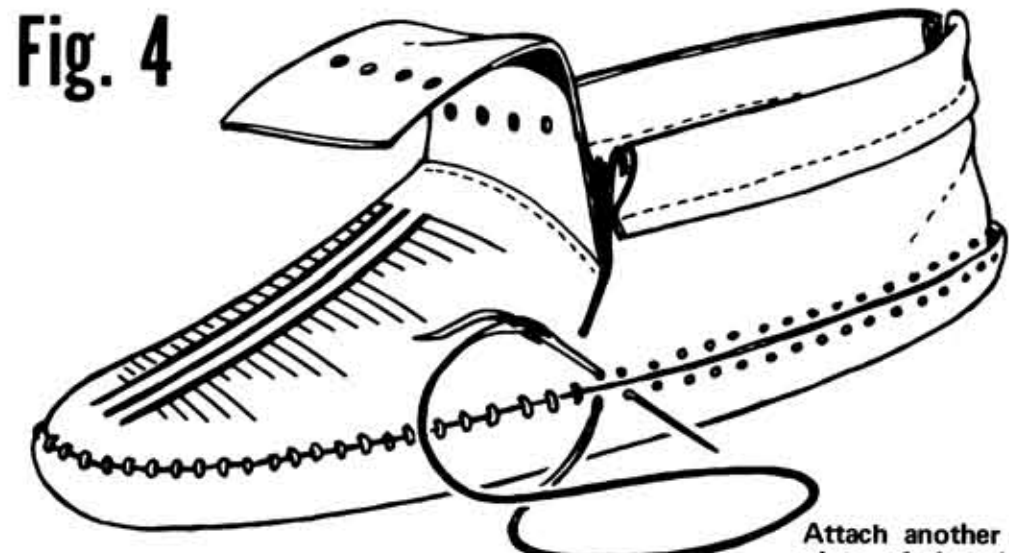

Start at the heel of the moccasin, the third hole over on the outside of the foot, leaving about 9" of thread remaining to finish the heel later. From the inside of the vamp insert the thread through the bottom hole and out through the starting hole in the sole. Go in through the top hole, cross over to the next bottom hole and repeat the stitch again. Do this all the way around the moccasin joining the vamp to the sole in this manner.

Fig. 5

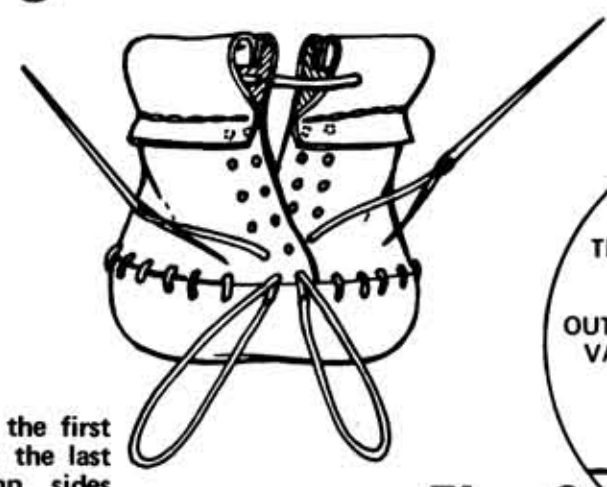

Attach another needle to the first piece of thread and with the last two holes in the vamp sides remaining, over-lap the outside over the inside. Double loop each hole with the thread going through into the inside. Make an "X" on the inside with the thread coming out the next hole up, with the threads as shown.

Fig. 6

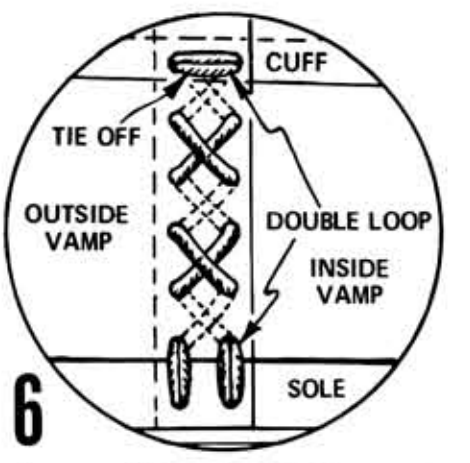

Continue making the "X's" on the inside and outside of the leather till you reach the top holes. There make a double loop horizontal, tying off on the inside.

DIRECTIONS

Choose a good leather for making your moccasins, one that is durable and soft. You can cut your own insoles if you have the foam rubber material or use the ones found in the drug stores. You might even wish to stitch a heavier sole to the bottom.

Glue the insole in position on the inside of the sole leather as shown. In stitching these moccasins the tightness of the stitching will help to determine the size and fit. Check mocs on your foot as you stitch. Remember they can always be retightened if they become too loose.

With the insole in position, start your stitching by inserting the thread from the inside out through the starting hole in the bottom of the vamp, then through the starting hole in the sole. Now go back into the inside of the vamp through the top hole, cross-over and down through the next bottom hole and back through to the outside again. Keep repeating this step till you go all the way around the moccasin as shown in Fig. 4.

Now join the heel together as stated in Figs. 5 and 6.

there, go in through the outside holes of the tongue and back out through the other center holes again. Tie-off the drawstring to fit the foot and your moccasin is complete. See Fig. 5 for drawstring.

If you have checked the moccasin on your foot while stitching, this moccasin should fit very comfortably.

A NOTE here: if your foot is too large for one pattern and too small for the next larger size, you may move the double holes around the vamp closer to the edge of the tracing pattern. Just remember to keep the same number of holes in the soles of the moccasins.

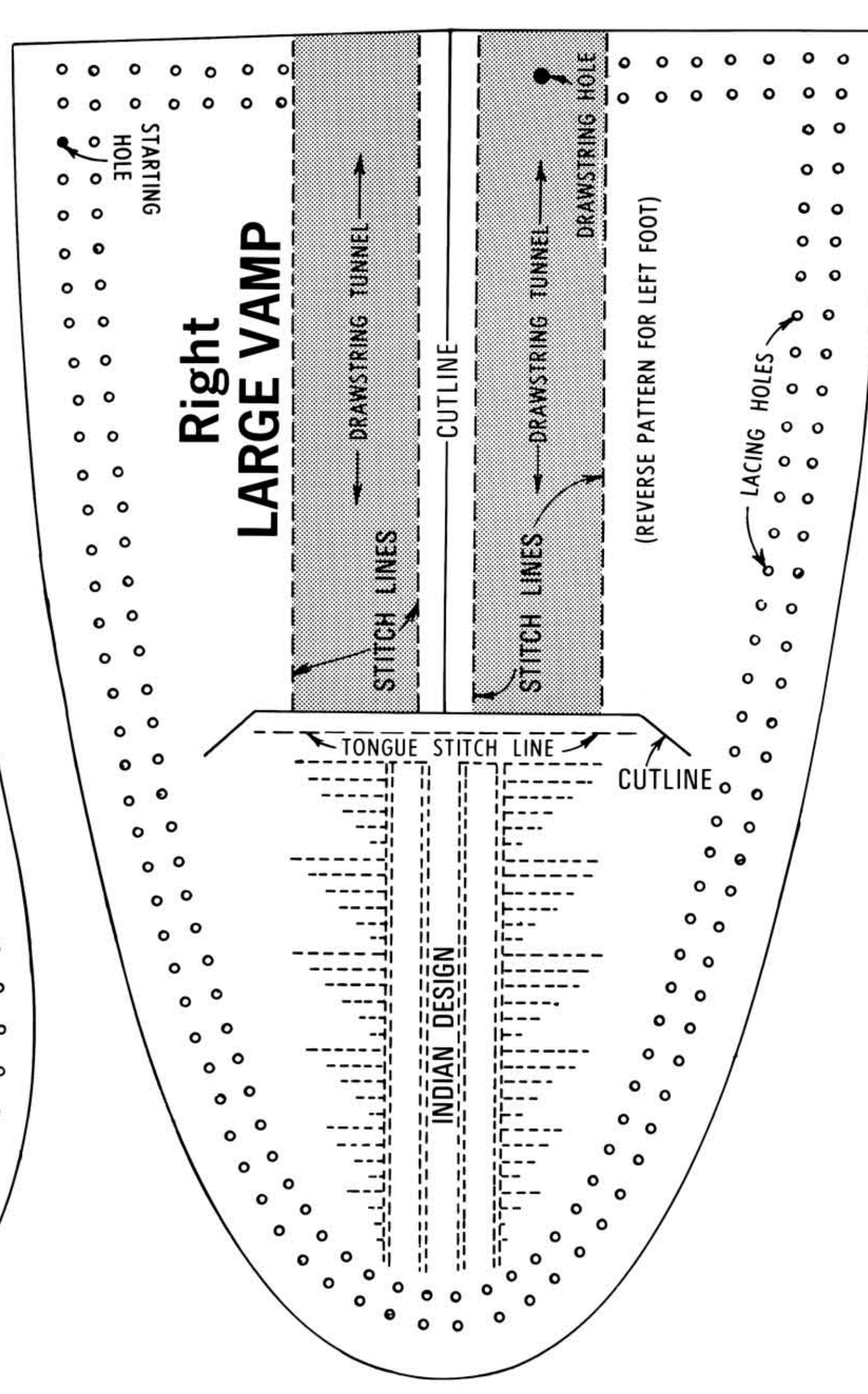
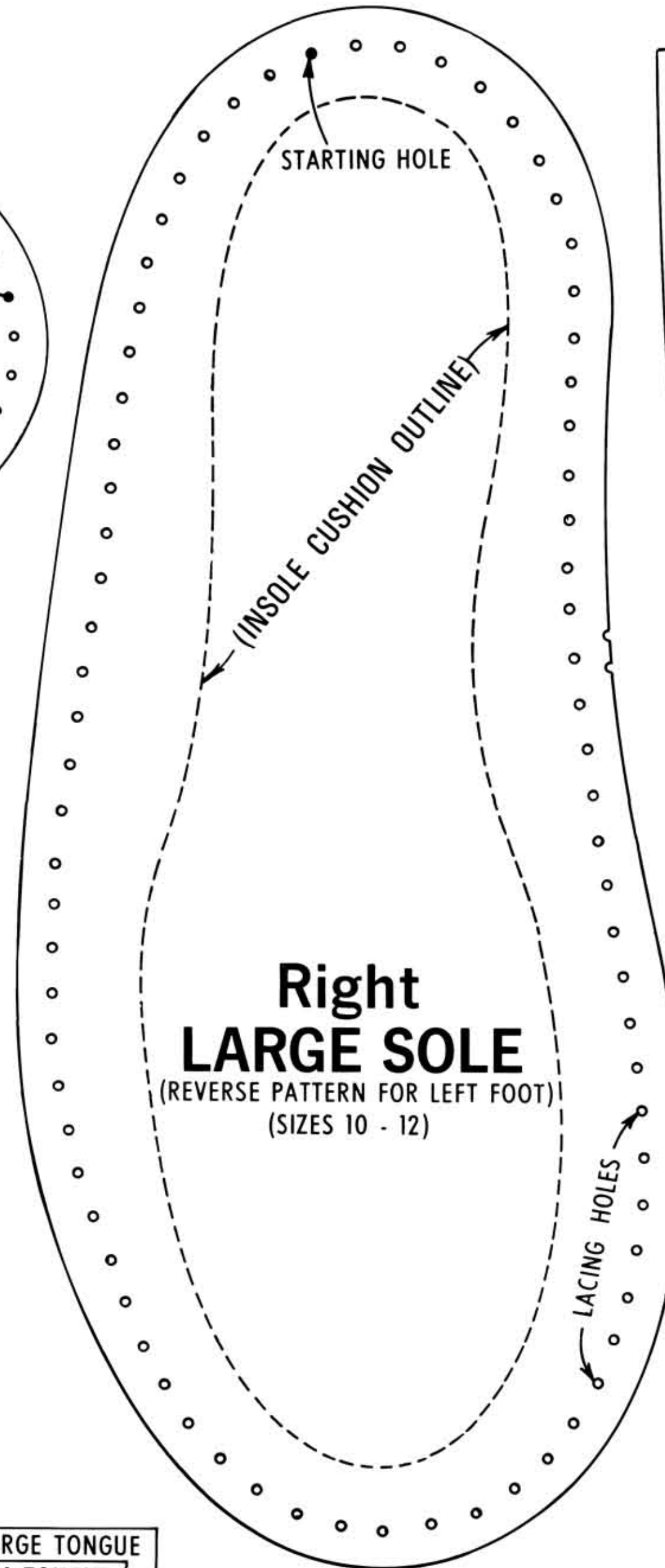
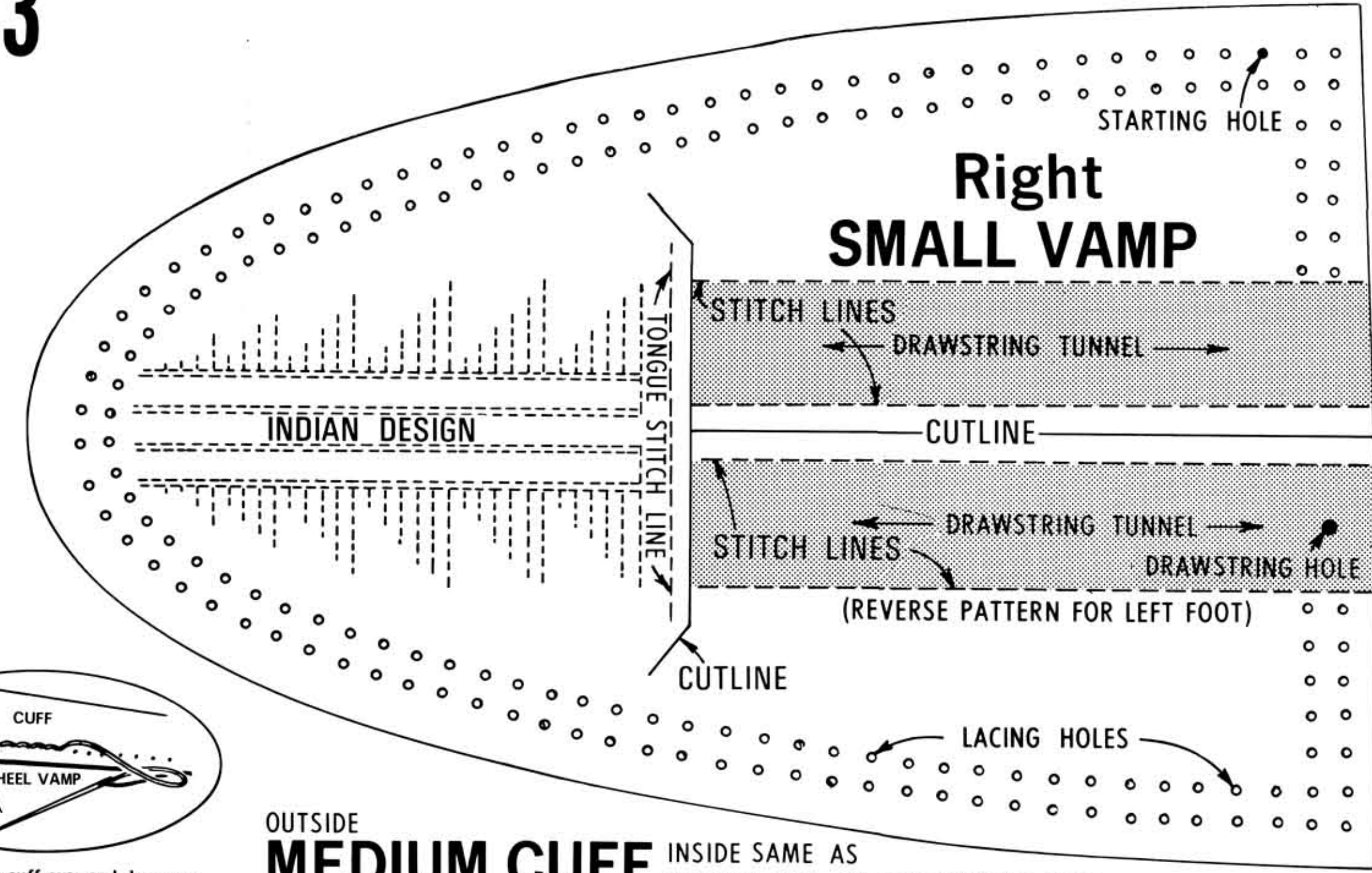
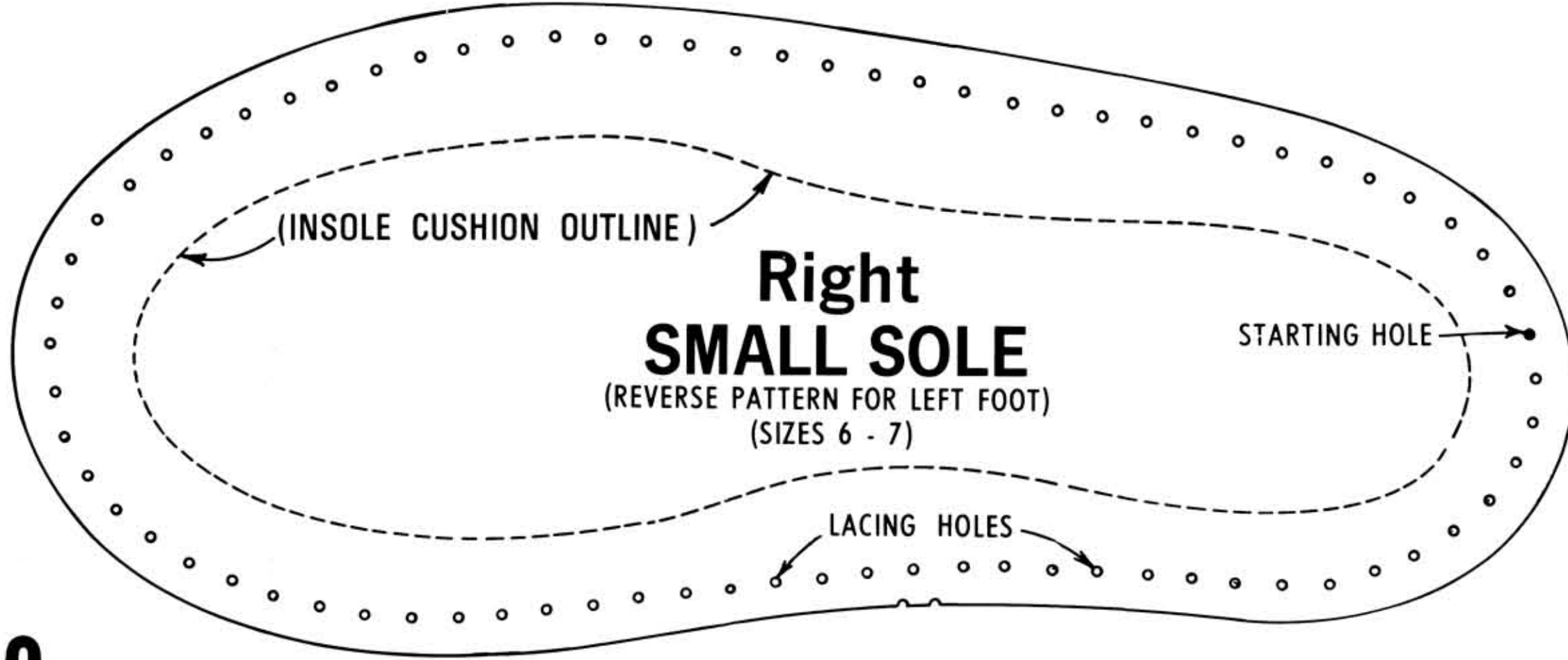

OUTSIDE MEDIUM CUFF INSIDE SAME AS OUTSIDE BUT NO DRAWSTRING HOLE

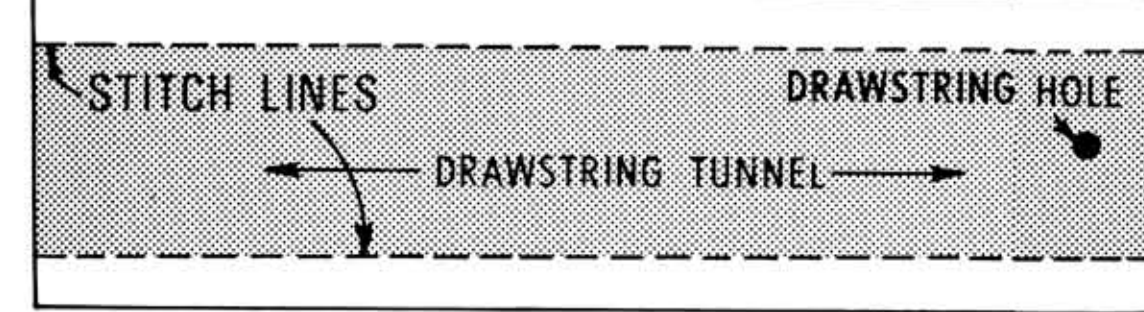

OUTSIDE LARGE CUFF INSIDE SAME AS OUTSIDE BUT NO DRAWSTRING HOLE

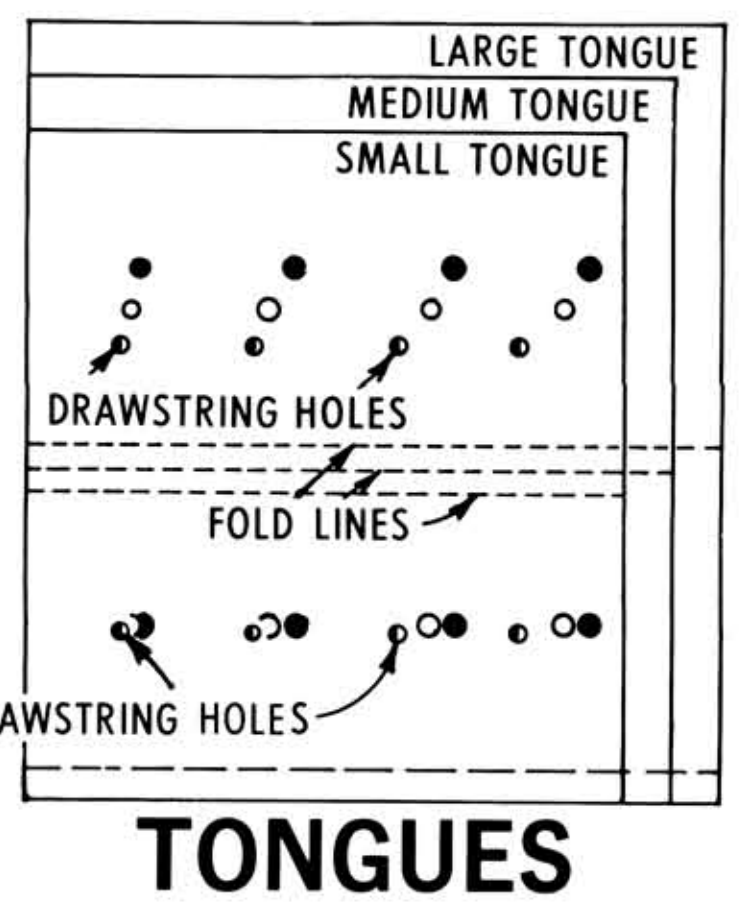
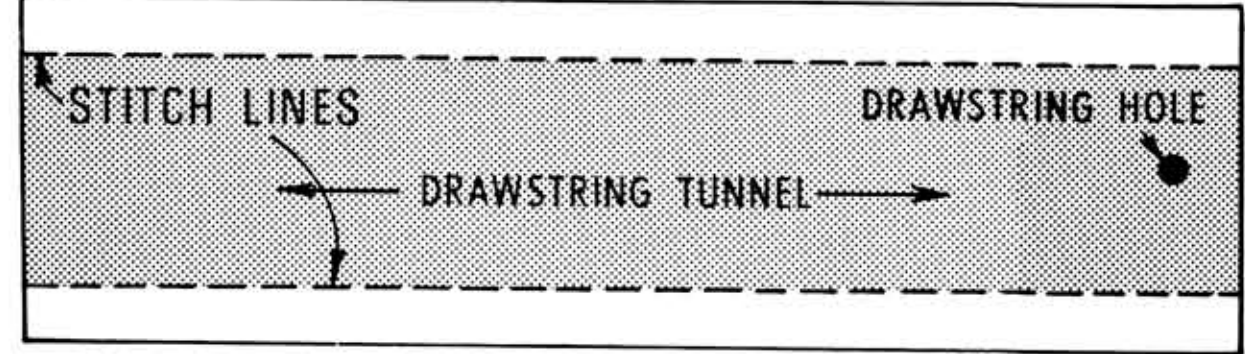

INSIDE SAME AS OUTSIDE BUT NO DRAWSTRING HOLE

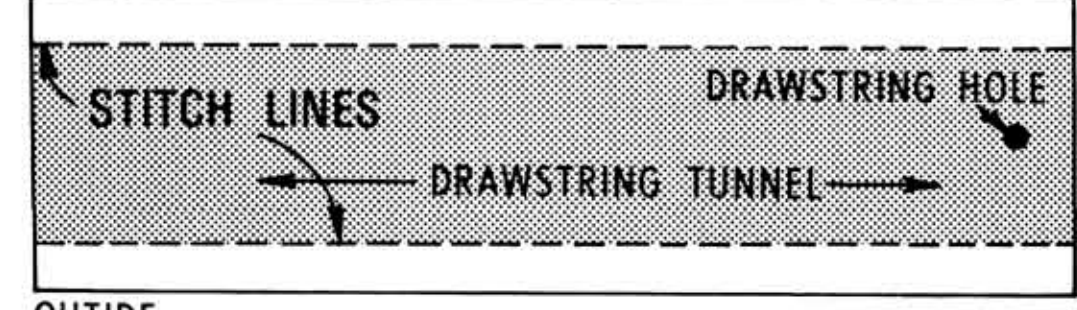

OUTSIDE SMALL CUFF

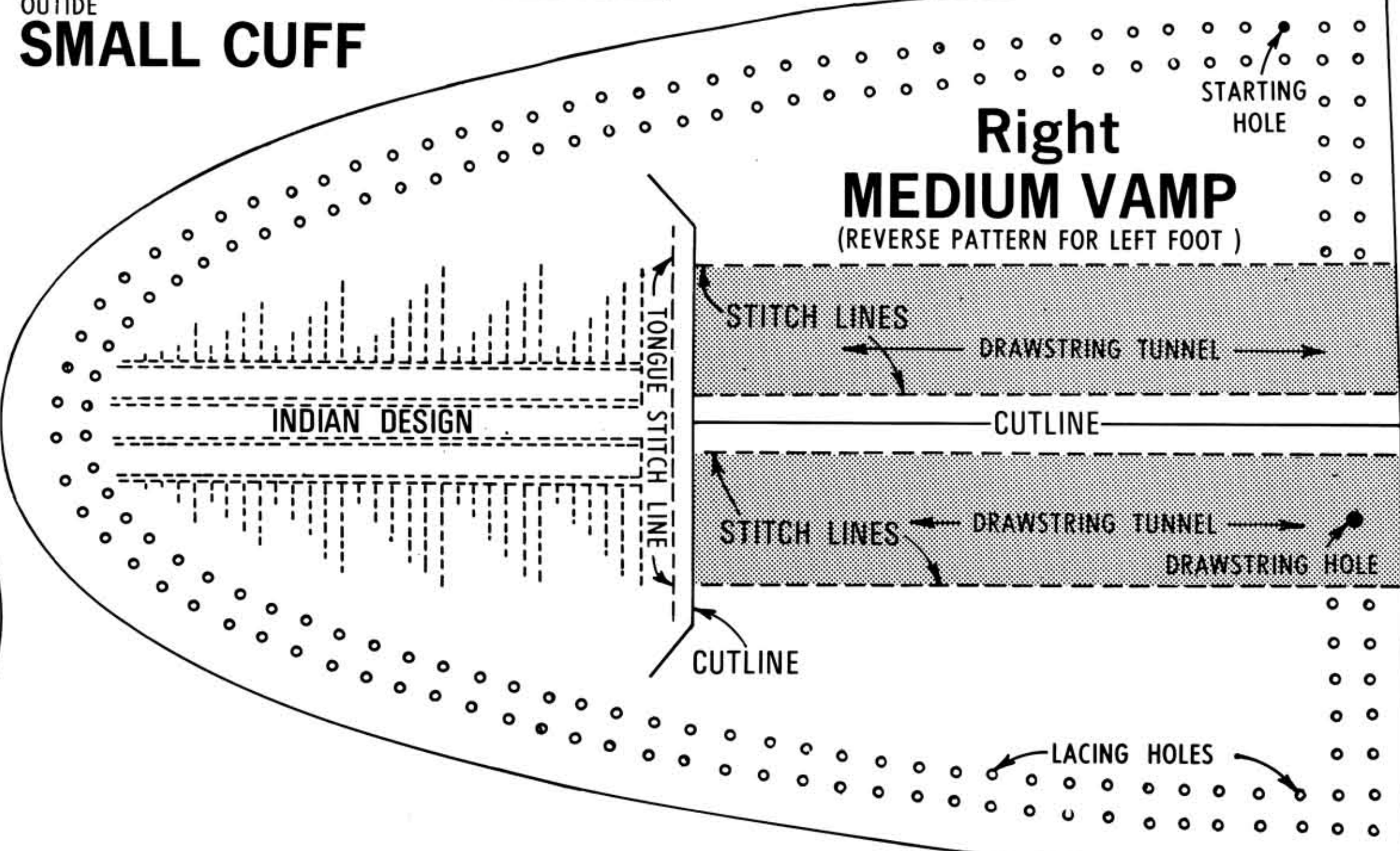
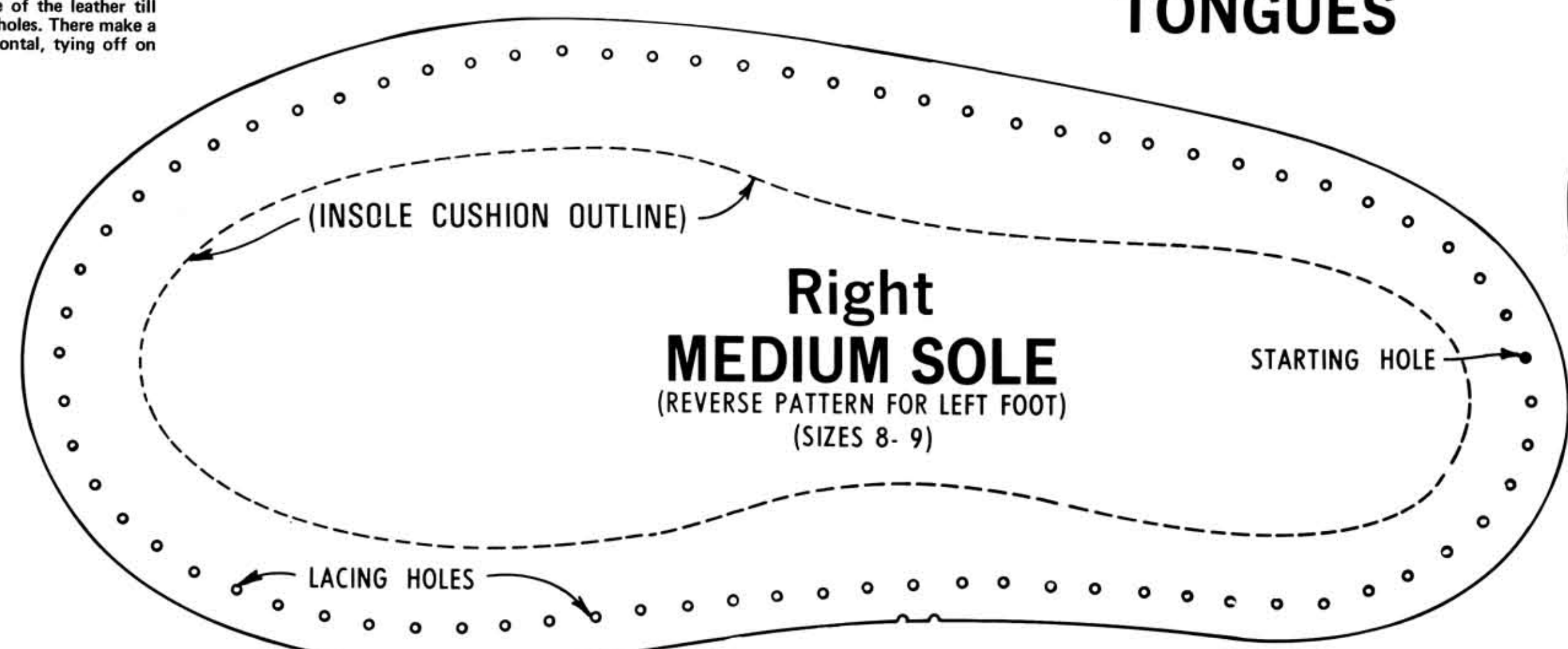

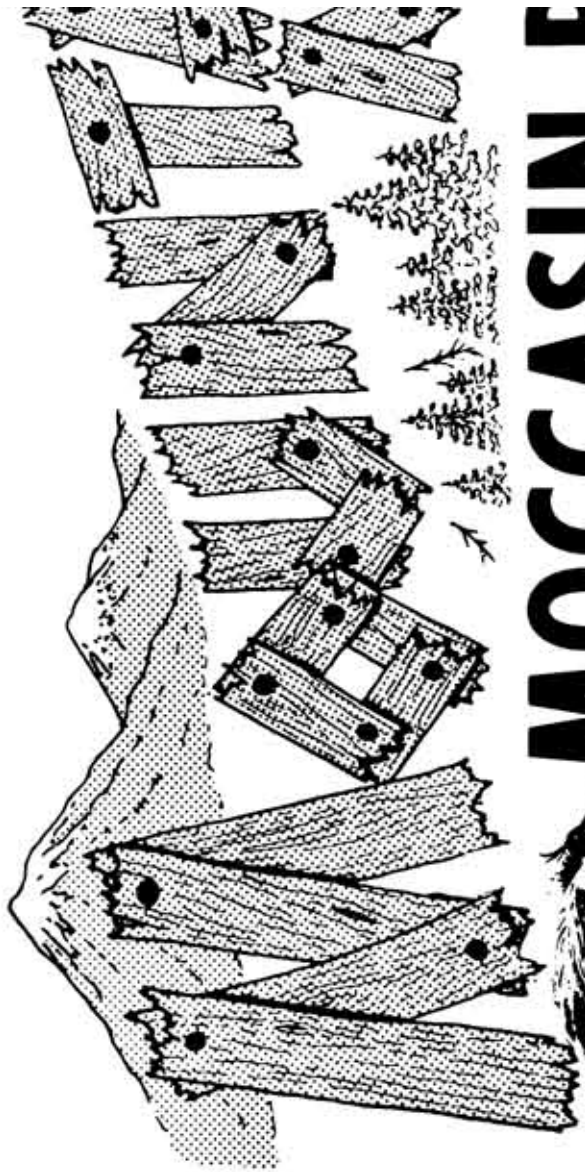

MOCCASIN F

by GENI



Needle T Instru

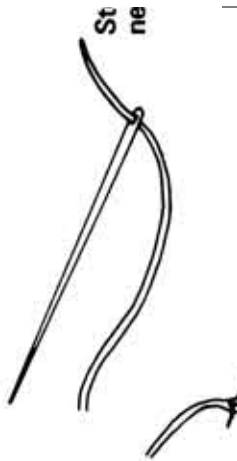

St
ne

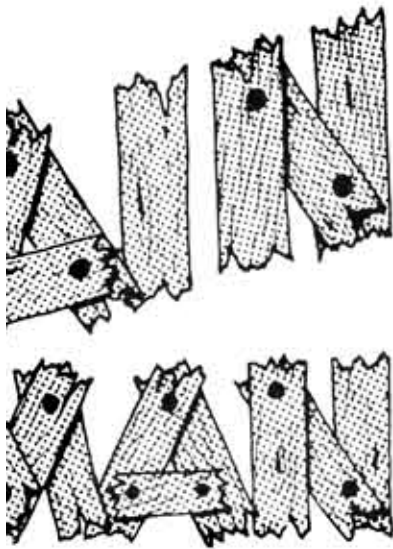

Stock No. 2695

PATTERNS

E NOLAND

threading actions

Step 1. Push end of thread through
needle eye about 1/2".

#3

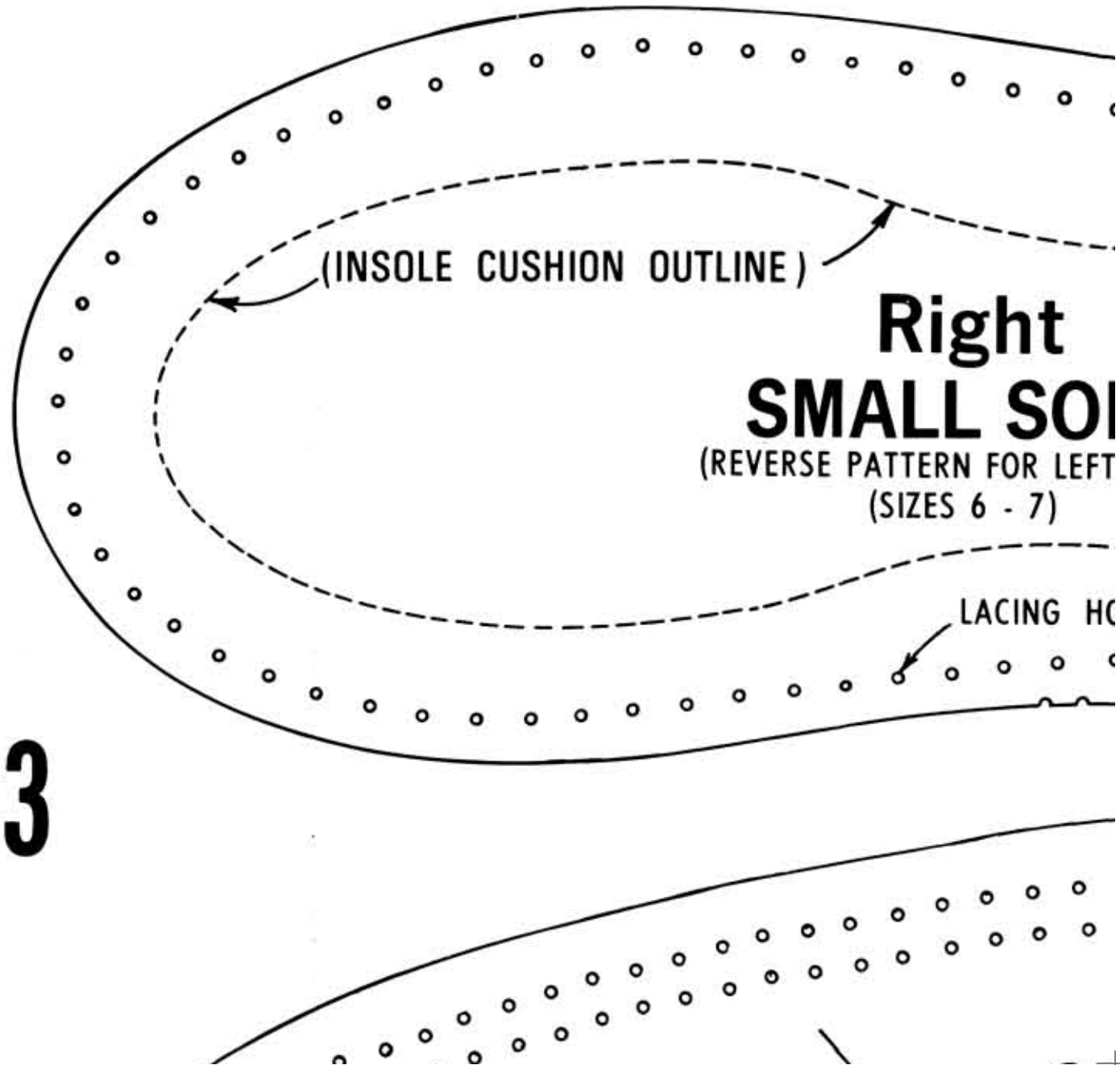

LE
(FOOT)

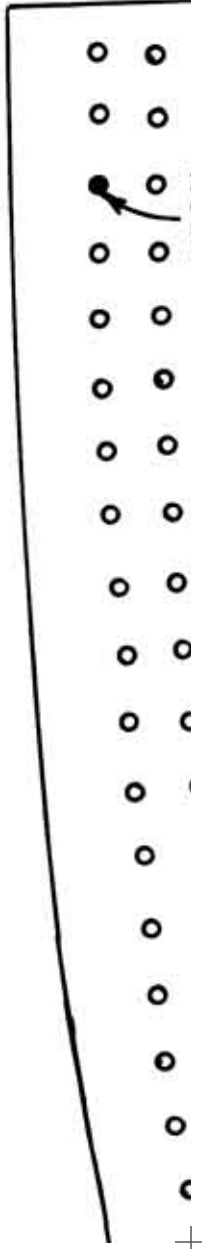
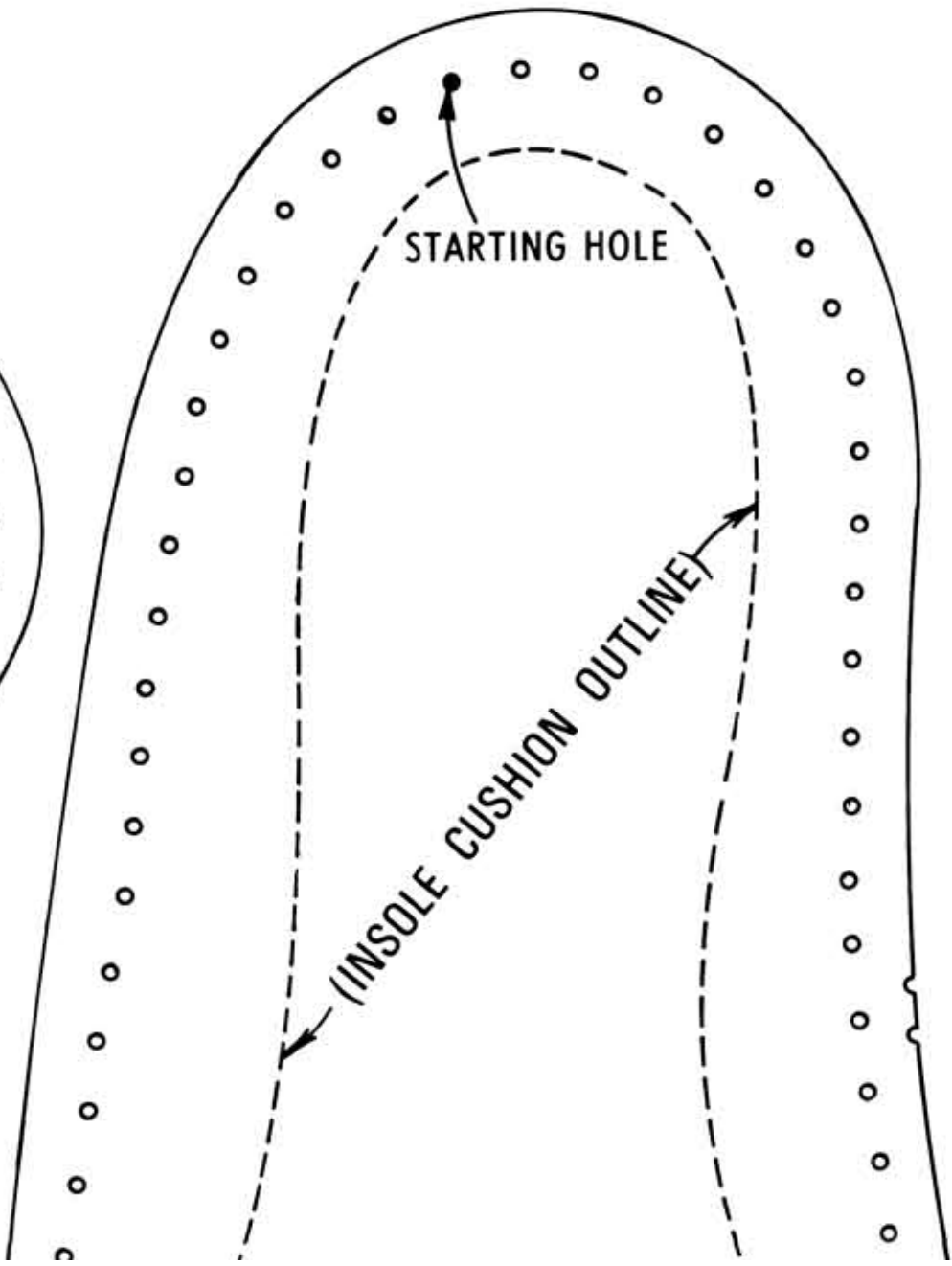
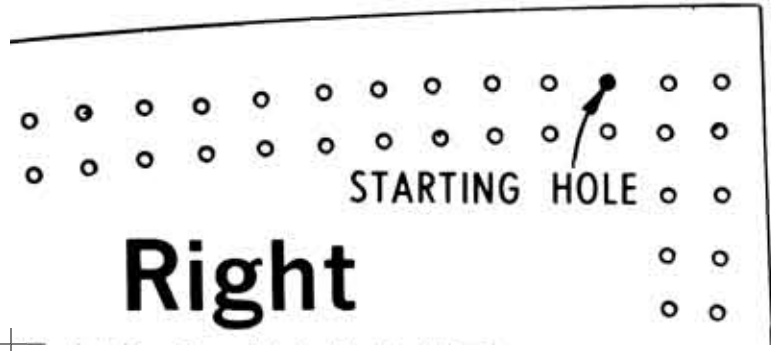
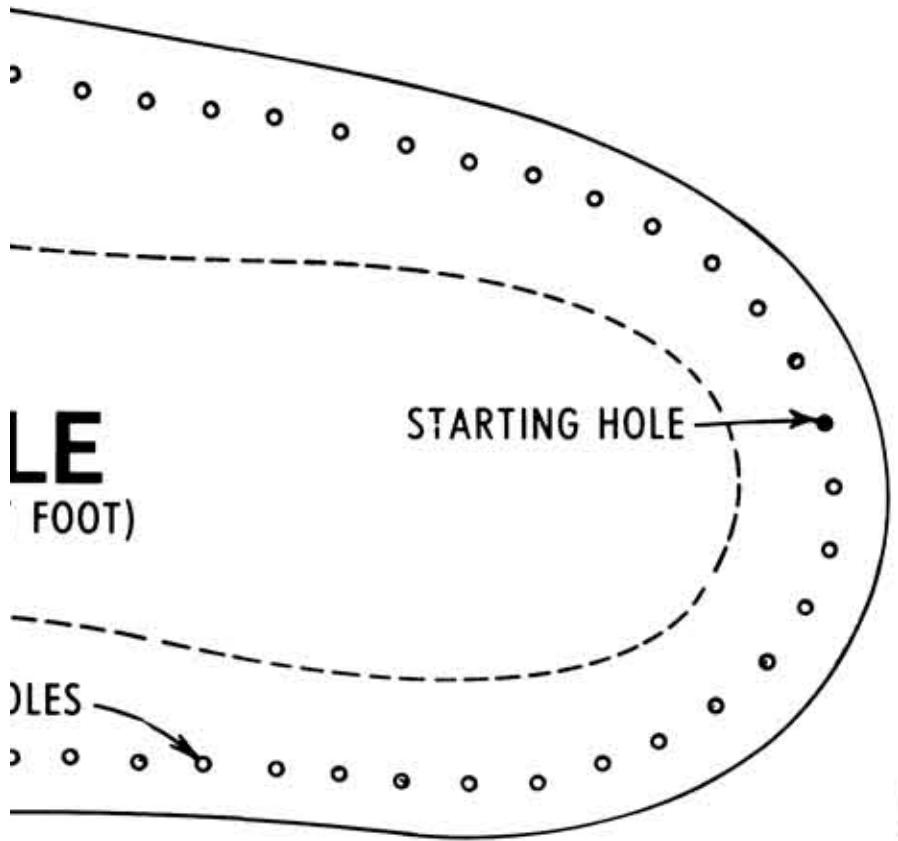

STARTING HOLE

Right LARGE VAMP

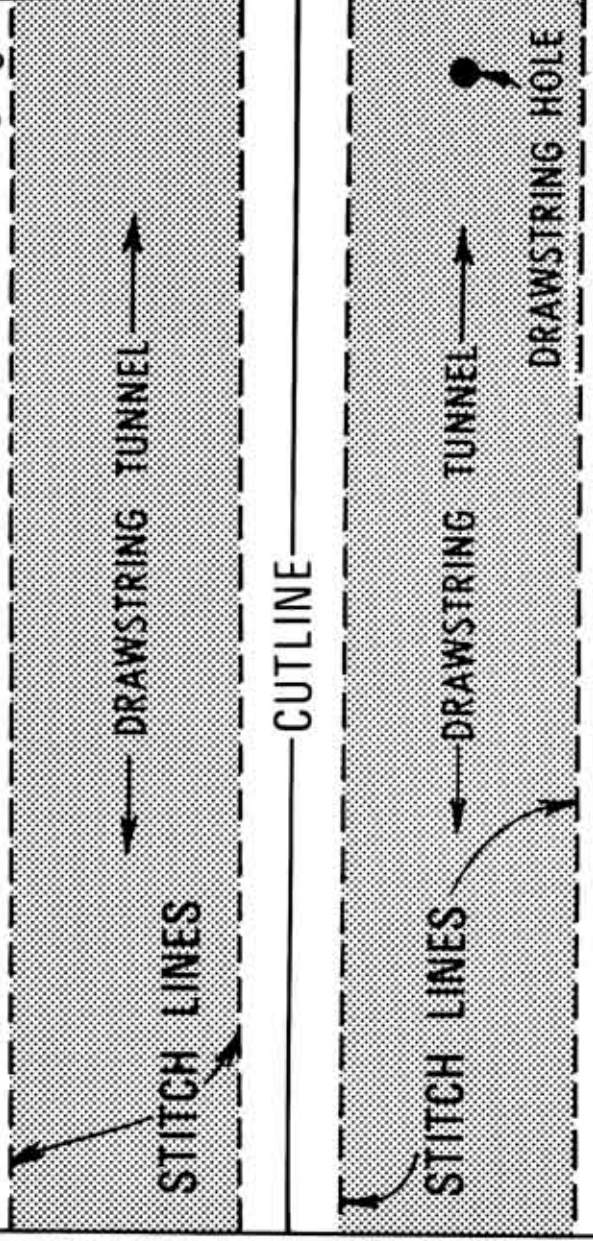

(REVERSE PATTERN FOR LEFT FOOT)

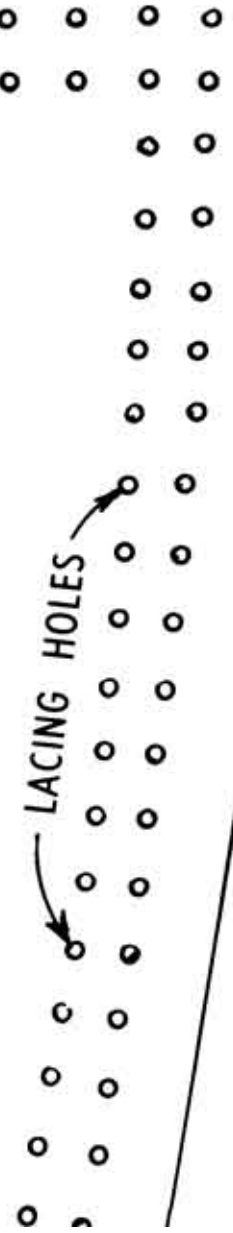

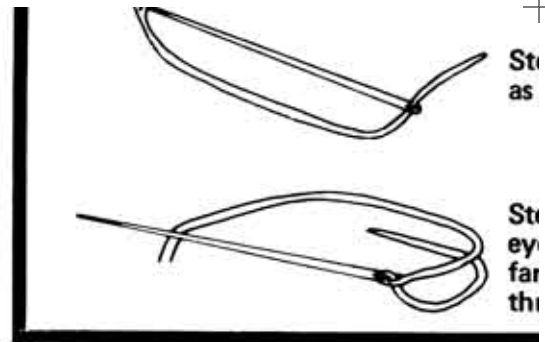

ASSEMBLY IN

Fig. 1

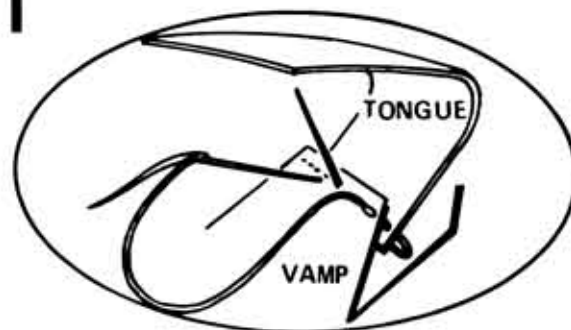

With a saddle stitch, stitch the tongue to the vamp. Place the tongue leather under or on the inside of the vamp.

Fig. 2



Stitch the cuff across the top edge of the heel across with the saddle stitch.

Fig. 4



Step 2. Pierce thread with needle point shown.

Step 3. Push thread upon needle to eye. Pull end of thread through eye as far as it will go. Hold needle and pull thread over eye to lock end of thread.

INSTRUCTIONS

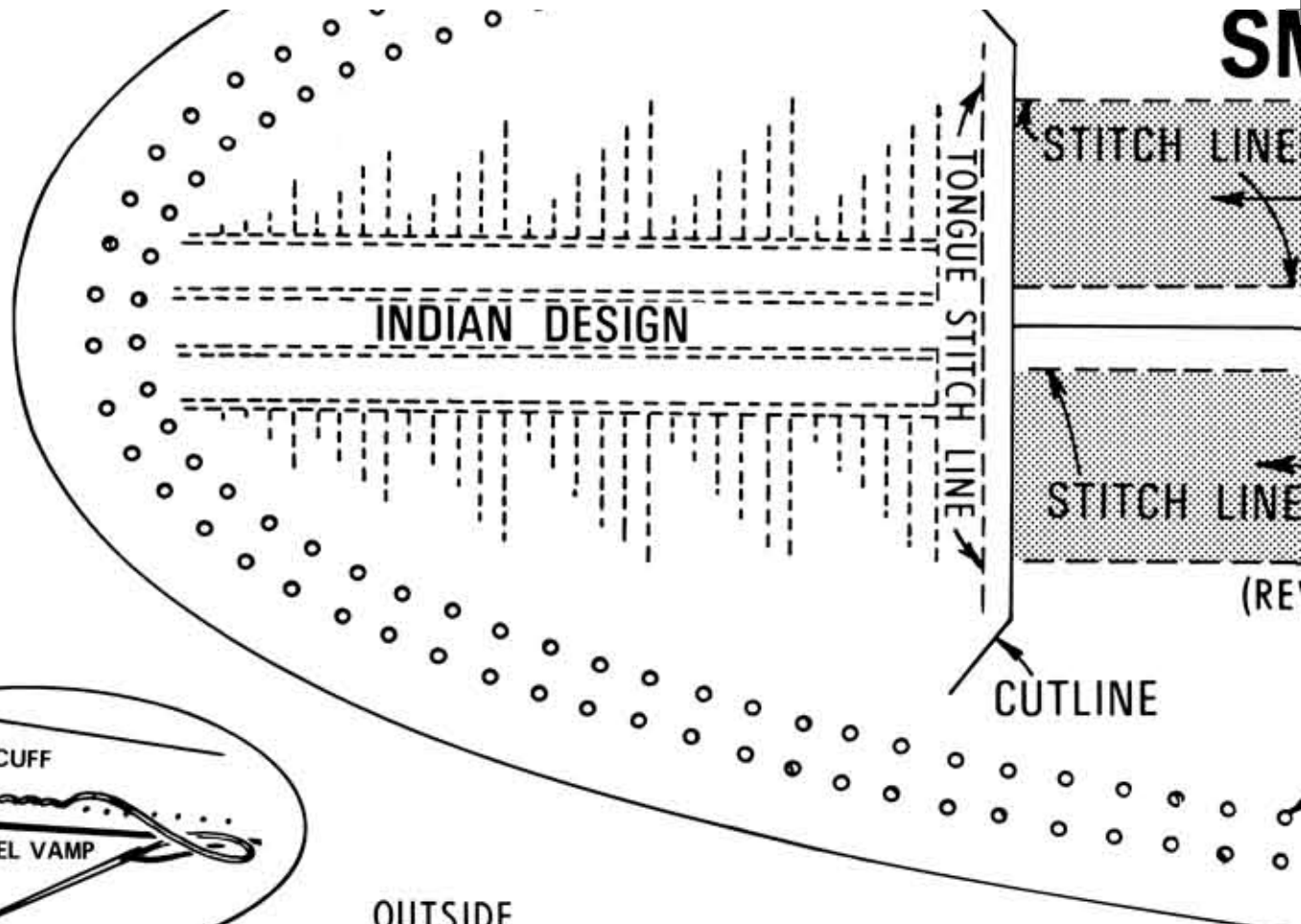
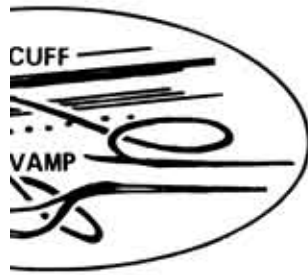
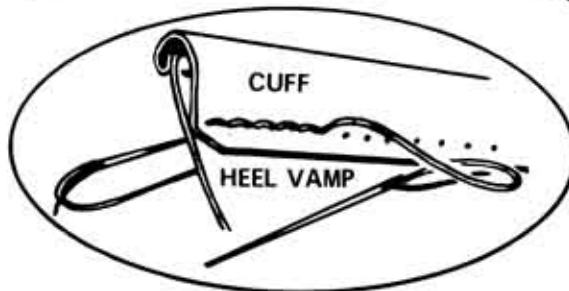

Fig. 3



Work in the vamp, starting from the heel and stitch all the way around with saddle stitch.



Now fold the cuff over and down on the outside and stitch across to form a drawstring tunnel. Do this with a saddle stitch.

OUTSIDE
MEDIUM CUFF INSIDE SAME AS MEDIUM CUFF BUT NO DRAWSTRING

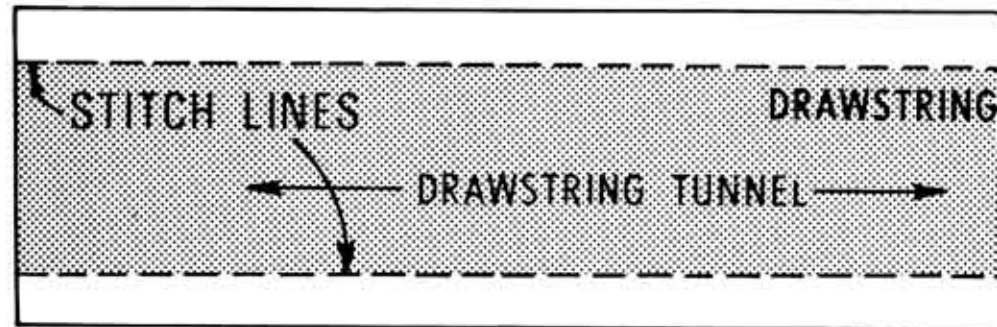

OUTSIDE
LARGE CUFF INSIDE SAME AS MEDIUM CUFF BUT NO DRAWSTRING

Fig. 5



SMALL VAMP

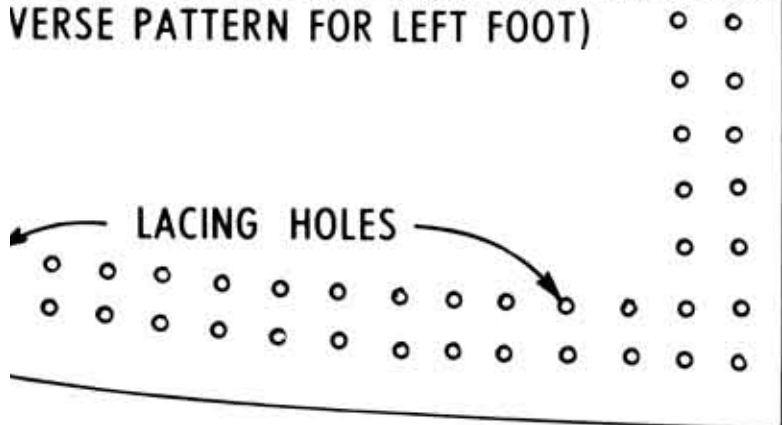
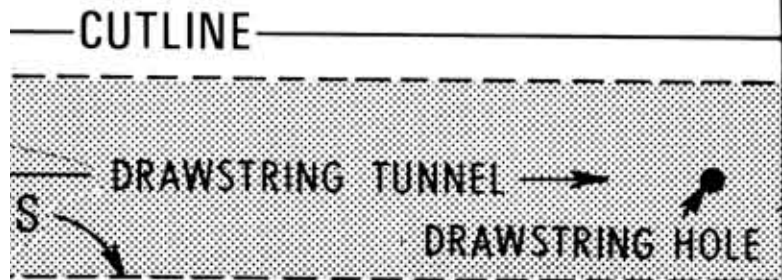

DRAWSTRING HOLE

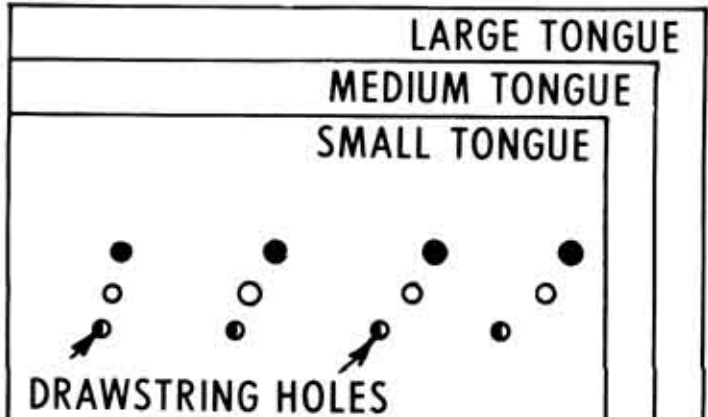

DRAWSTRING HOLE

Right LARGE SOLE

(REVERSE PATTERN FOR LEFT FOOT)
(SIZES 10 - 12)

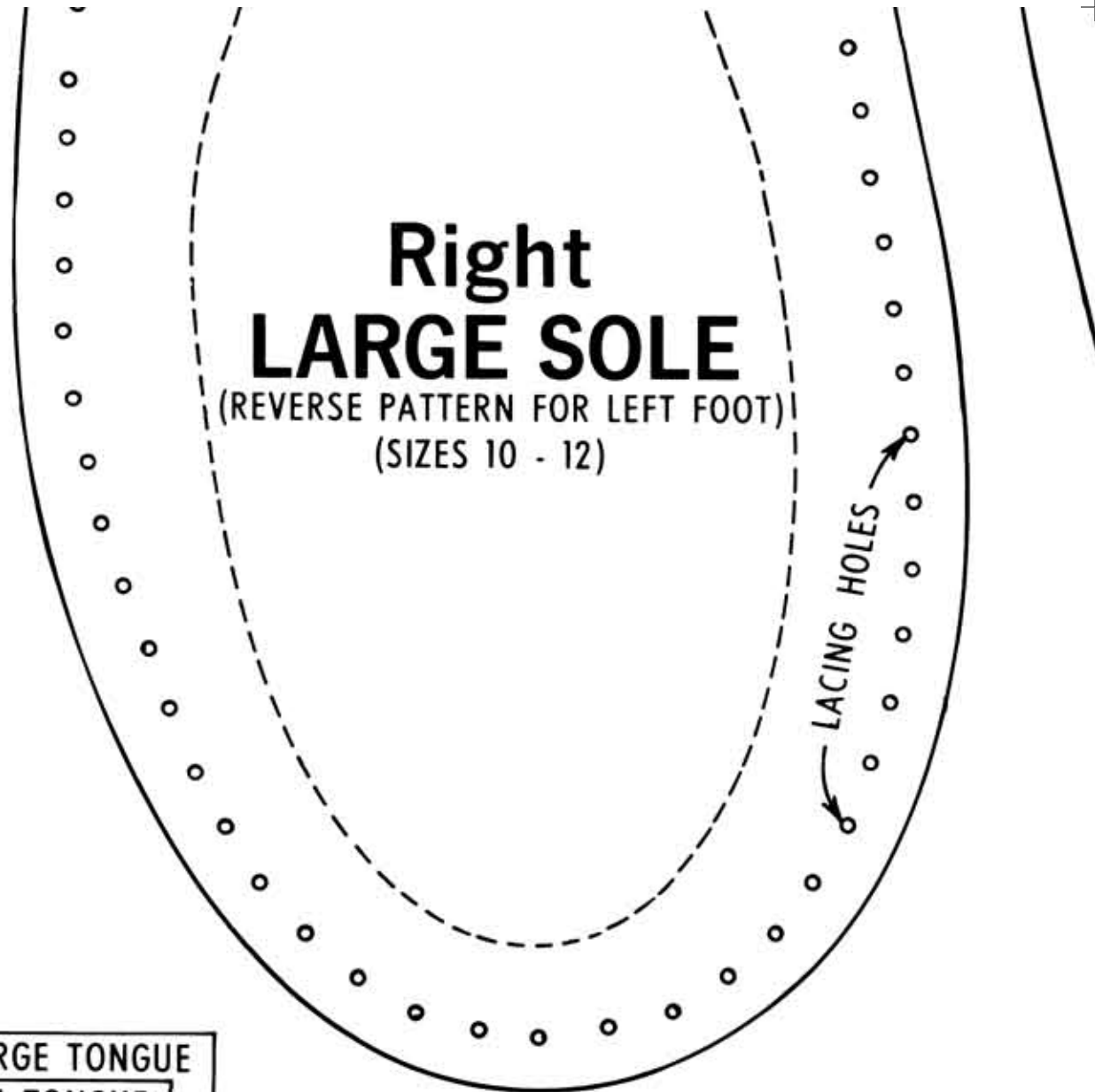

INSIDE SAME AS OUTSIDE BUT NO DRAWSTR

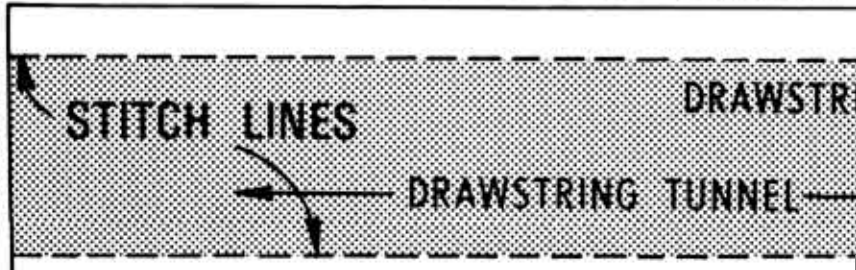

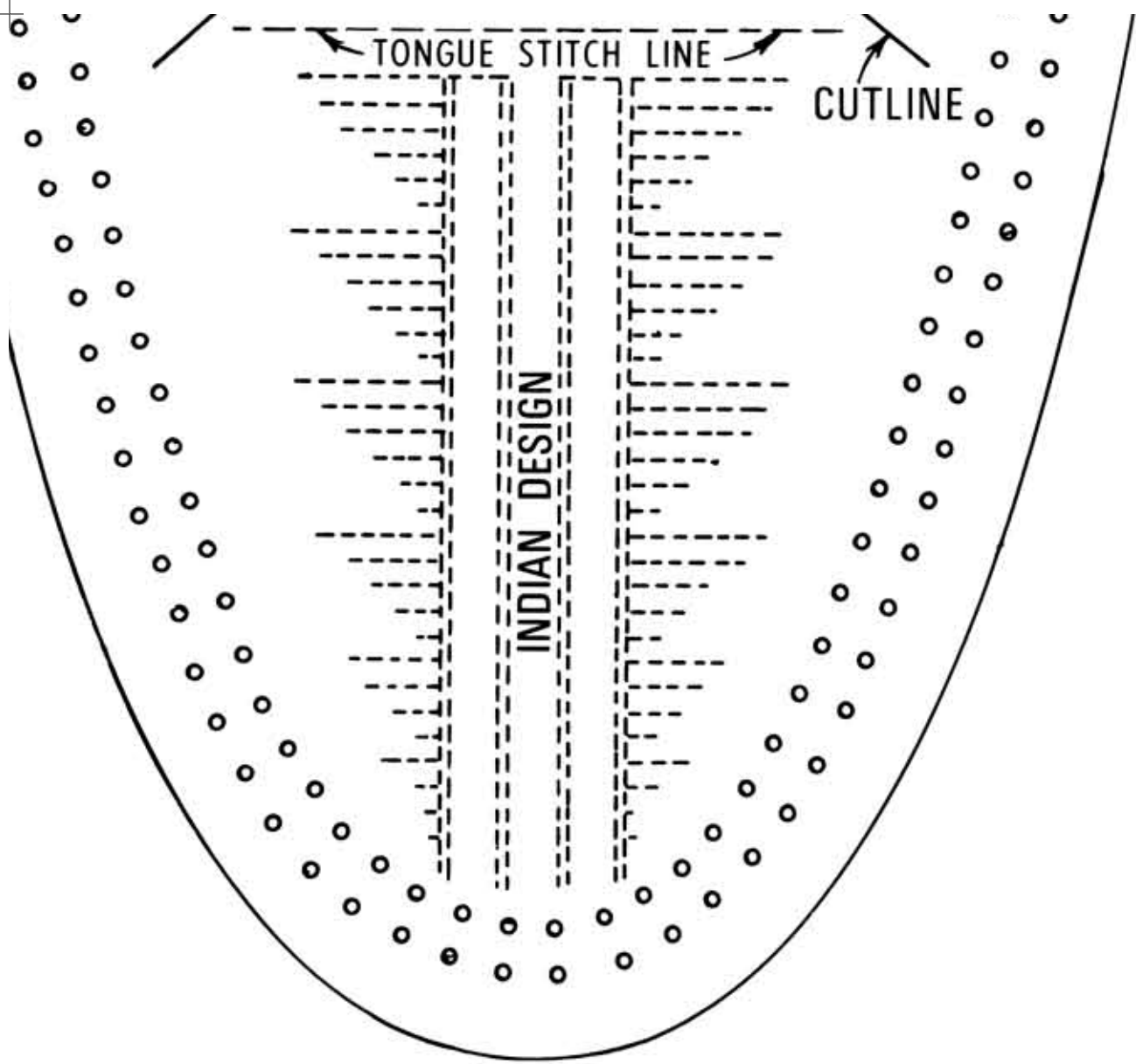

ING HOLE

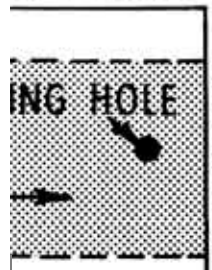

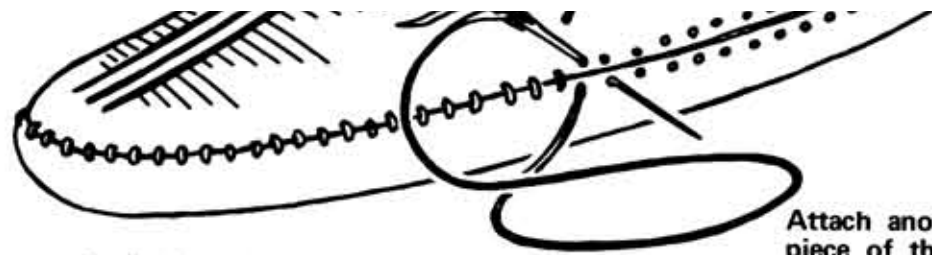

Start at the heel of the moccasin, the third hole over on the outside of the foot, leaving about 9" of thread remaining to finish the heel later. From the inside of the vamp insert the thread through the bottom hole and out through the starting hole in the sole. Go in through the top hole, cross over to the next bottom hole and repeat the stitch again. Do this all the way around the moccasin joining the vamp to the sole in this manner.

Attach another needle to a piece of thread and work two holes in the vamp remaining, over-lap the thread on the inside. Double loop with the thread going through the inside. Make an "X" inside with the thread crossing the next hole up, with the thread as shown.

DIRECTION

Choose a good leather for making your moccasins, one that is durable and soft. You can cut your own insoles if you have the foam rubber material or use the ones found in the drug stores. You might even wish to stitch a heavier sole to the bottom.

Glue the insole in position on the inside of the sole leather as shown. In stitching these moccasins the tightness of the stitching will help to determine the size and fit. Check moccasins on your foot as you stitch. Remember they can always be retightened if they become too loose.

Start by cutting out the pattern designs and punch all the holes. Add the Indian design or make your own, but do this before you begin the stitching. Use a good heavy waxed thread for stitching the vamp and sole together. A light weight or medium thread may be used in stitching the tongue and cuffs to the vamp.

With the insole in position, start stitching by inserting the thread from the inside out through the starting hole in the bottom of the vamp, then through the starting hole in the sole. Now go back inside of the vamp through the next hole, cross-over and down through the next hole and back through to the outside. Keep repeating this step till you go all the way around the moccasin as shown.

Now join the heel together as stated in steps 5 and 6.

Insert the drawstring through both holes in the tongue on one side, go through the outside holes of the tongue, go through the drawstring tunnel to the outside of the foot. Go through the vamp and in through the cuff on the inside of the foot. Continue through the drawstring tunnel back to the tongue area again.

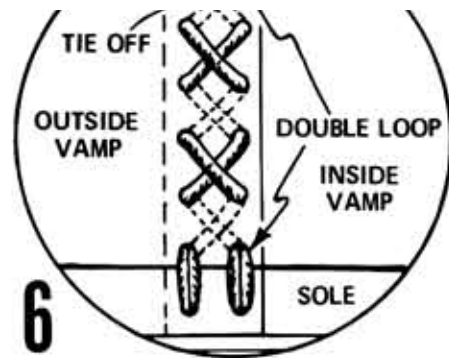
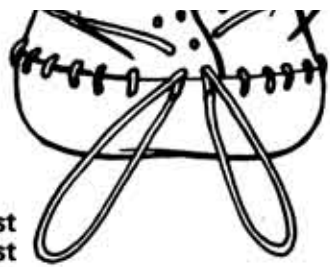
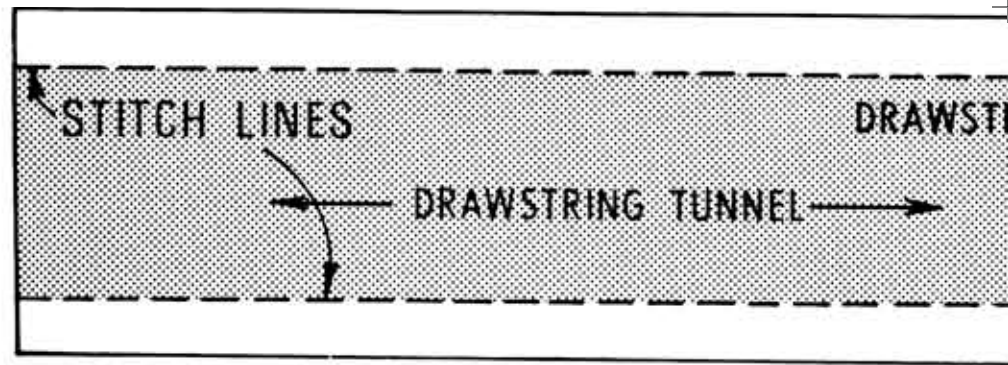

Fig. 6

Continue making the "X's" on the inside and outside of the leather till you reach the top holes. There make a double loop horizontal, tying off on the inside.



o the first
th the last
amp sides
outside over
each hole
rough into
K" on the
oming out
he threads

S

art your
from the
le in the
ugh the
k into the
top hole,
t bottom
ide again.
o all the
in Fig. 4.

there, go in through the outside holes of the tongue and back out through the other center holes again. Tie-off the drawstring to fit the foot and your moccasin is complete. See Fig. 5 for drawstring.

If you have checked the moccasin on your foot while stitching, this moccasin should fit very comfortably.

A NOTE here; if your foot is too large for one pattern and too small for the next larger size, you may move the double holes around the vamp closer to the edge of the tracing pattern. Just remember to keep the same number of holes in the soles of the moccasins.

d in Figs.

h center
and out
gue. Now
the heel,
ough the
inside of
rawstring
in. Once

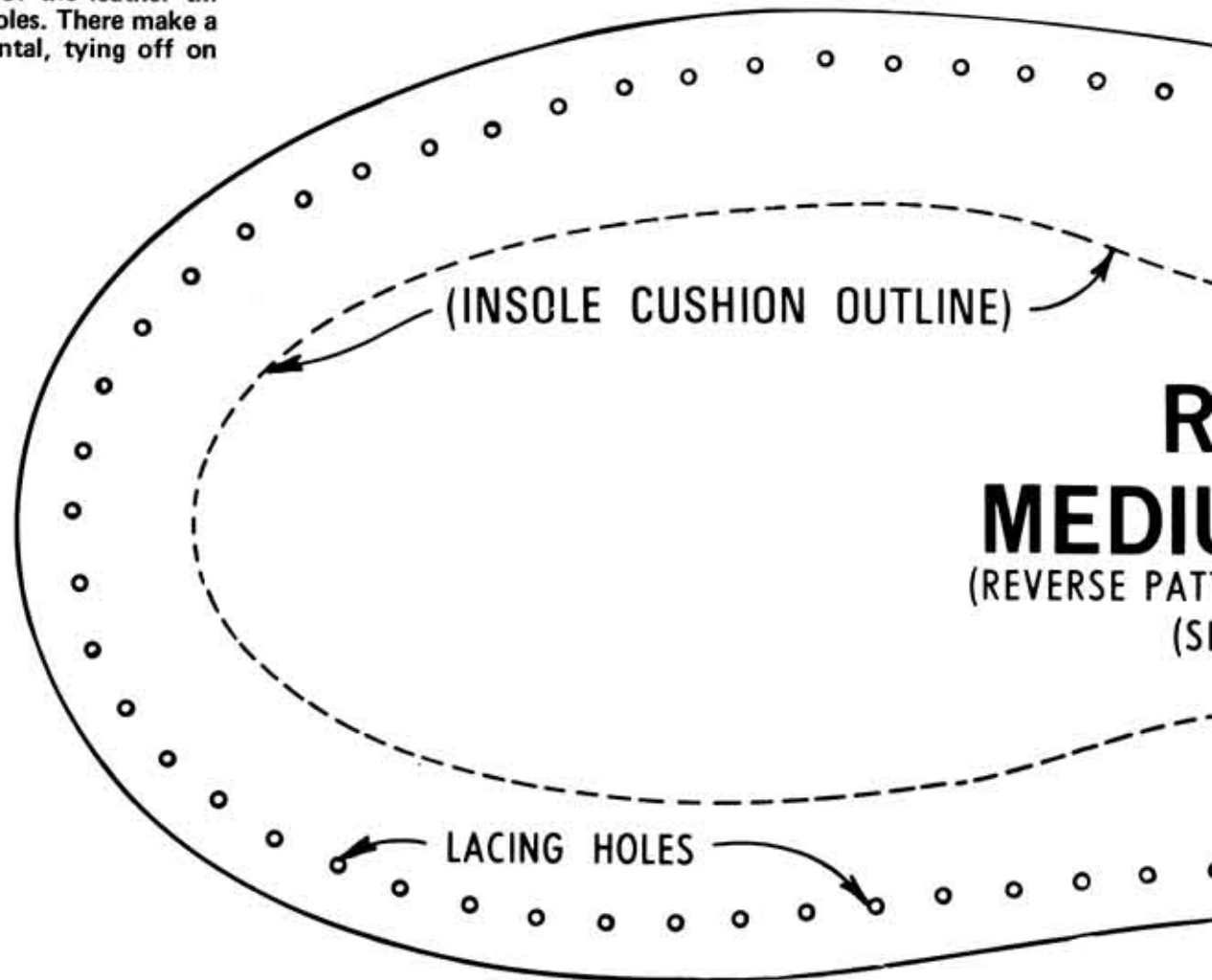

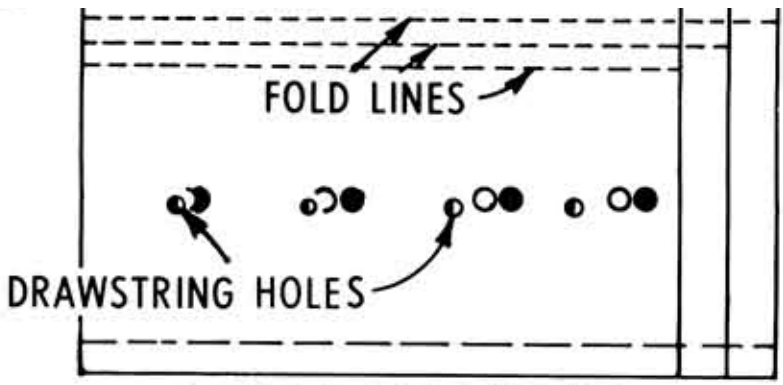
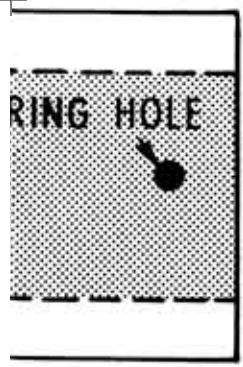

TONGUES

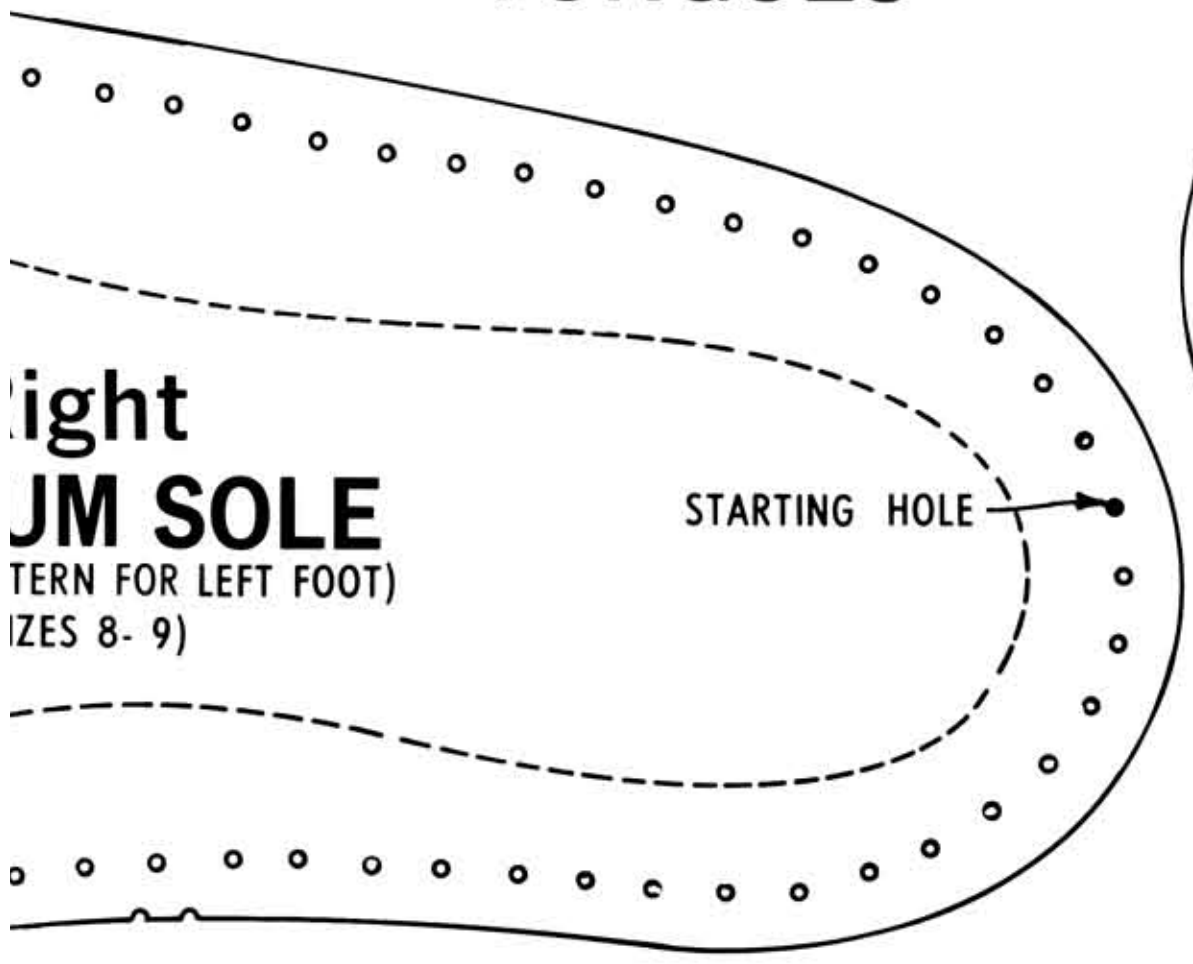

Light
JM SOLE
(TERN FOR LEFT FOOT)
(SIZES 8- 9)

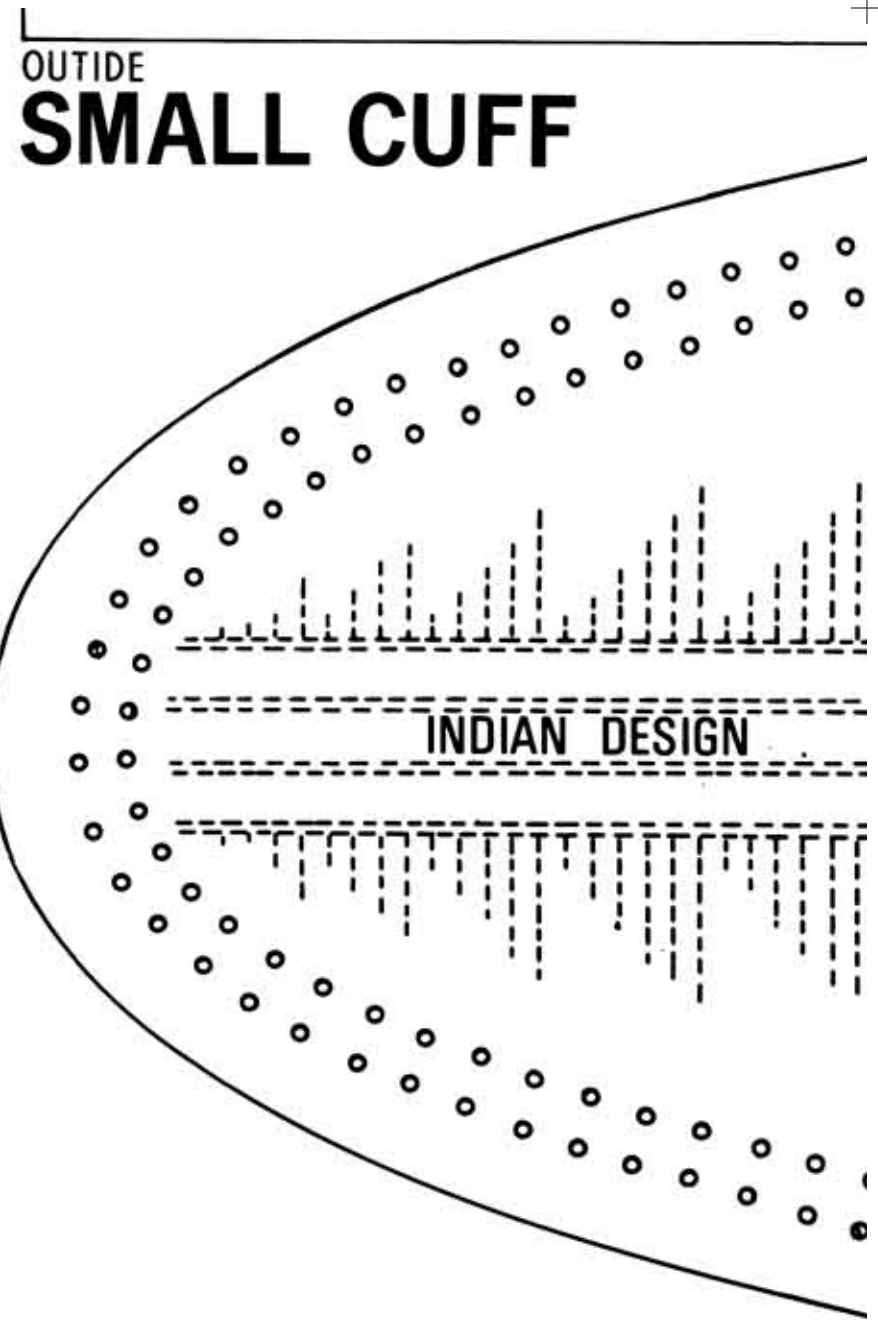

OUTSIDE
SMALL CUFF

Right MEDIUM VAMP

(REVERSE PATTERN FOR LEFT FOOT)

STARTING
HOLE

STITCH LINES

DRAWSTRING TUNNEL

CUTLINE

STITCH LINES

DRAWSTRING TUNNEL

DRAWSTRING HOLE

CUTLINE

LACING HOLES

