

LEATHER VISOR PATTERN PAK

NO. 2661

COMPLETE PATTERNS
& INSTRUCTIONS FOR
THE THREE SUN VISORS
PICTURED BELOW.



VISOR PATTERN



MATERIALS NEEDED:

- 7-8 oz. Nature-Tand or Live Oak Knife
- Mallet
- Two Size 00 Harness Needles
- 4 ft. Waxed Thread
- Size 2 Punch
- Size 00 Punch or Stitching Awl
- Craftool French Skiving Tool
- Craftool Bevel-eze Edge Beveler
- Size 2 (Optional)
- Craftool Circle Edge Slicker (Optional)
- 1 Medium Rapid Rivet
- Craftool Rivet Setter
- Craftool Leather Stamps (for the design of your choice)
- Omega Dye
- Omega Carnauba Cream or Finish Coat
- 1" Buckle



Distributed by
TANDY WAREHOUSE COMPANY
Fort Worth, Texas 76107

NATURE-TAND DYEING INSTRUCTIONS

The Nature-Tand dyeing technique allows you to apply dye to the surface of the leather to contrast with the stamped and natural impressions in the leather. With this technique the dye will not enter the stamped impressions. The dyes used are spirit solvent such as Omega Dye.

Step 1: Wrap a length of cloth around a sponge or wooden block several times. Apply dye to the cloth and blot on a paper towel until cloth has enough dye remaining to color only the surface of the leather. If too much dye remains it may run into the impressions. For shading an edge or small area, use a small piece of sponge without a cloth.

Step 2: With the cloth, apply dye to surface of leather, rubbing briskly so a burnished effect is achieved. Apply more dye to cloth as needed, blotting before applying to leather. Dye all edges.

For a distinctive edge, dye the edges and border area along them with dark brown or black.

For a more finished look, the back side of the Nature Tand leather may be dyed with Omega Dye and finished with Omega Carnauba Cream or Omega Finish Coat.

The basic colors recommended are: dark brown, medium brown, tan, light brown, Cordovan, or a combination of red (applied first) and dark brown.

Step 3: After dye has been applied, wait until leather dries before applying a finish. Omega Carnauba Cream or Finish Coat make excellent finishes for this type leather and dye.

RAPID RIVET SETTING INSTRUCTIONS

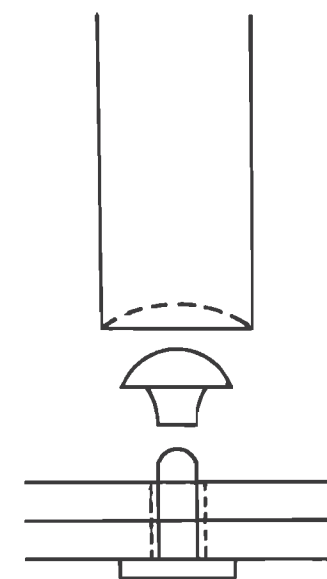

For best results use a rivet setter and rawhide mallet. Use rivet slightly longer than thickness of leathers. Punch hole in leather (use drive or rotary punch) slightly larger than rivet. Place rivet post through leathers and place on hard, smooth, dense surface. Place rivet cap on post. Place concave end of rivet setter on cap (be certain rivet is centered so edges of setter will not mark rivet cap) and tap sharply with rawhide mallet once or twice. Check to see that rivet is set tightly in leather and does not turn.

HANDSTITCHING INSTRUCTIONS

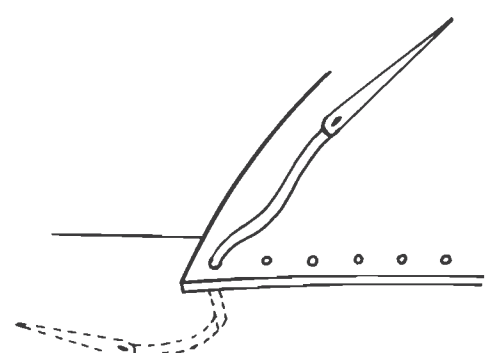

Step 1: Attach needle to each end of waxed thread and push one needle through first hole and pull to center to thread.

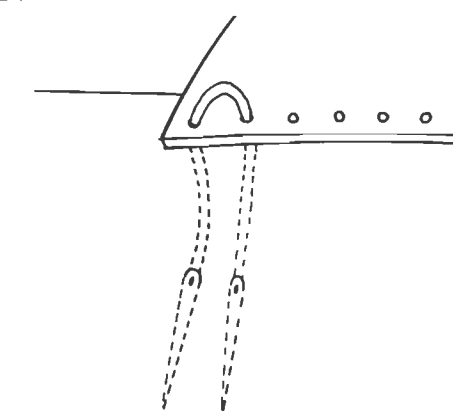

Step 2: Push needle from FRONT side through second hole.

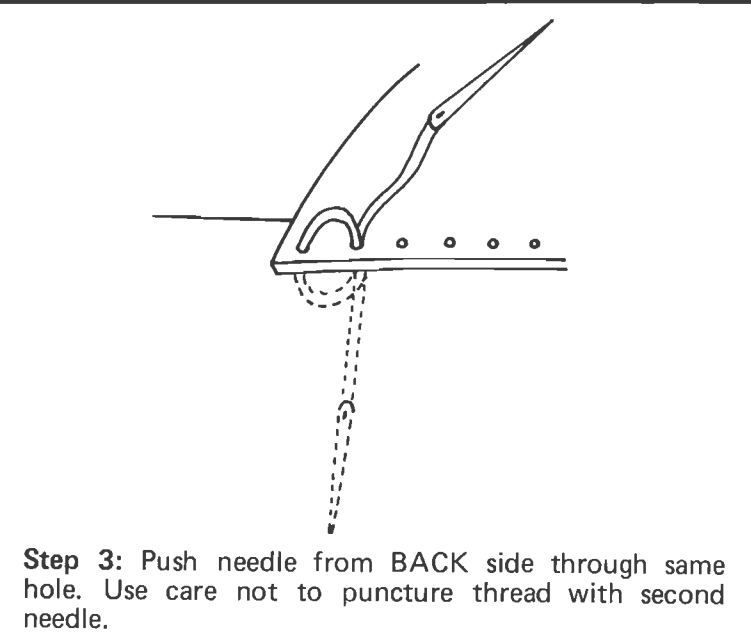

Step 3: Push needle from BACK side through same hole. Use care not to puncture thread with second needle.

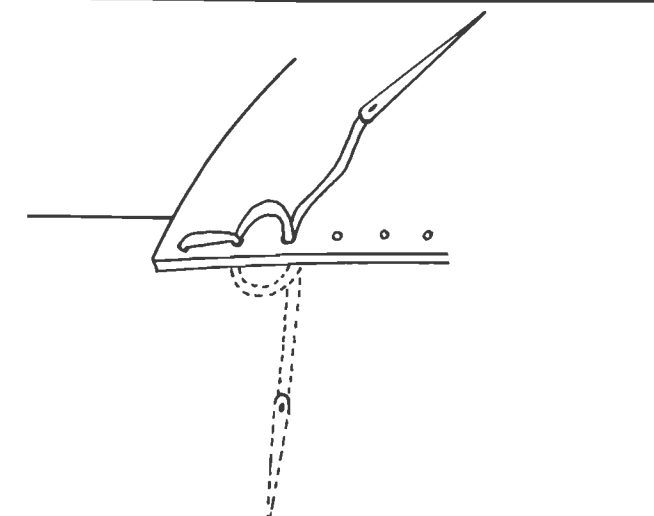

Step 4: Pull stitch tight. Push needle from FRONT side through third hole. Push needle from BACK side through same hole and pull stitch tight.

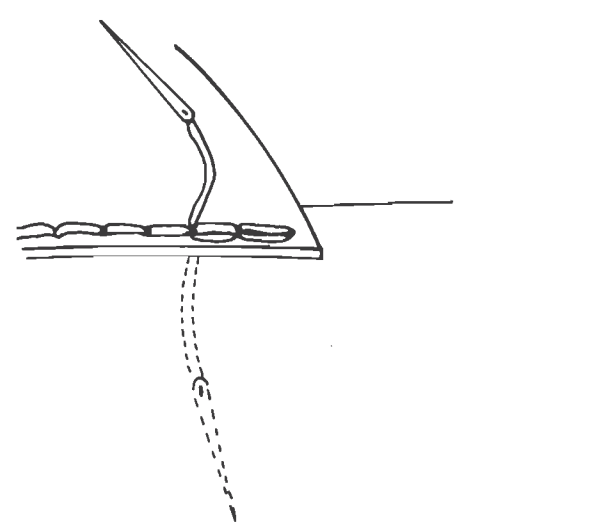

Step 5: To finish off, back stitch through last two holes and cut threads off flush with leathers.

ASSEMBLY INSTRUCTIONS FOR VISOR

Step 1: Use the cutting patterns to cut the leather parts and punch the holes. Skive the shaded area of the Visor Bill and edge the Visor Bill and Headband. Design the leather with designs of your choice, then dye and finish the parts following the Nature-Tand Dyeing Instructions.

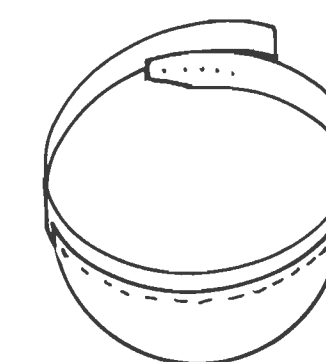

Step 2: Stitch the Visor Bill to the Headband following the Hand Stitching Instructions.

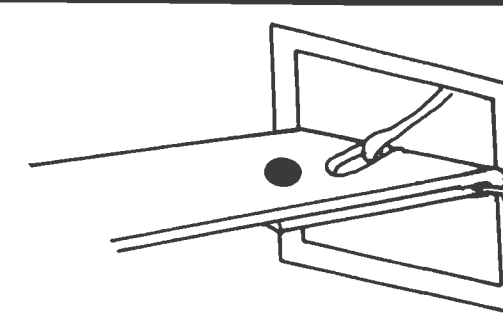

Step 3: Attach the 1" buckle to the headband with a medium Rapid Rivet following the Rapid Rivet Setting Instructions.

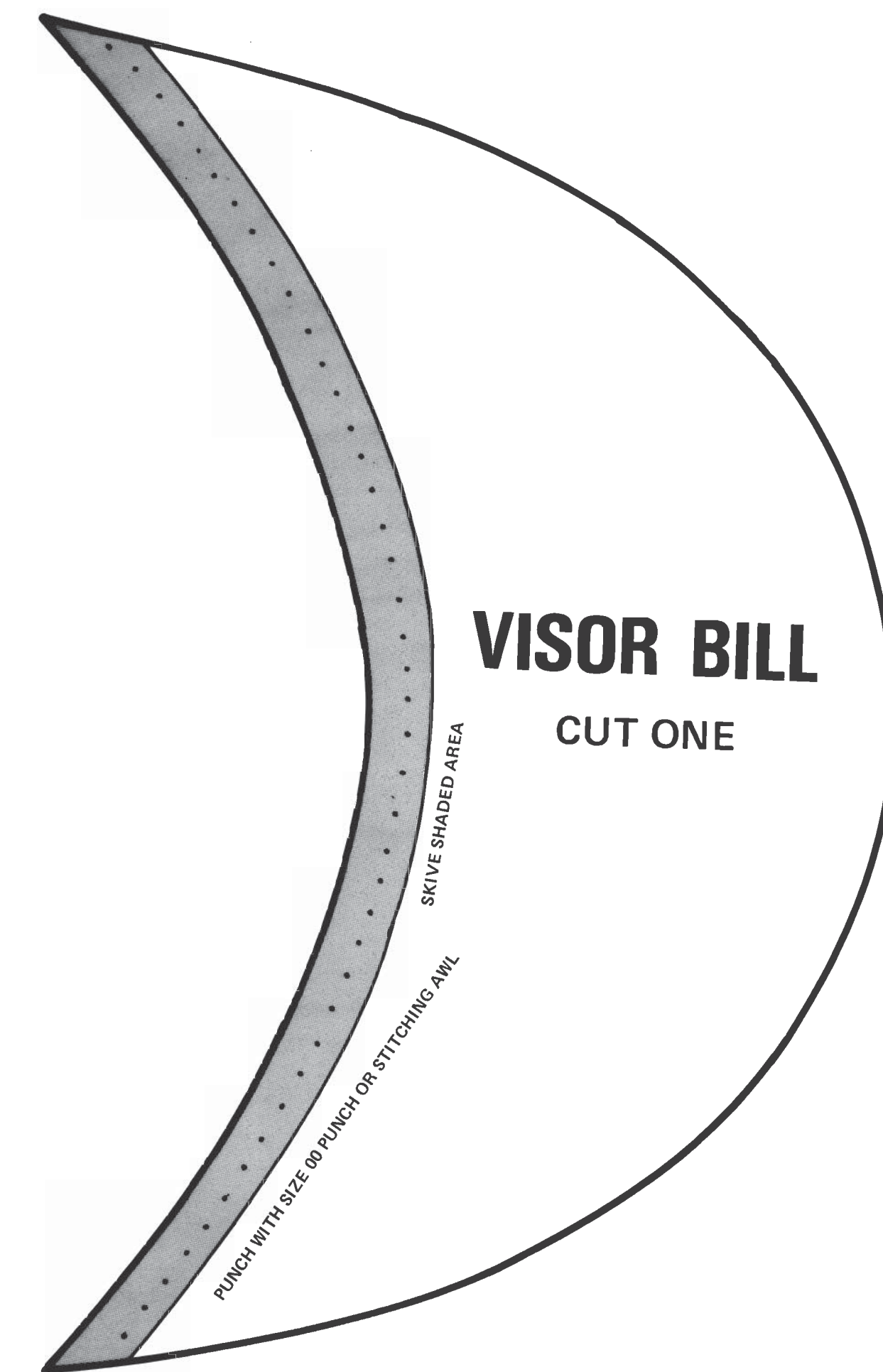

(No part of this or any other page may be reproduced without written permission.)

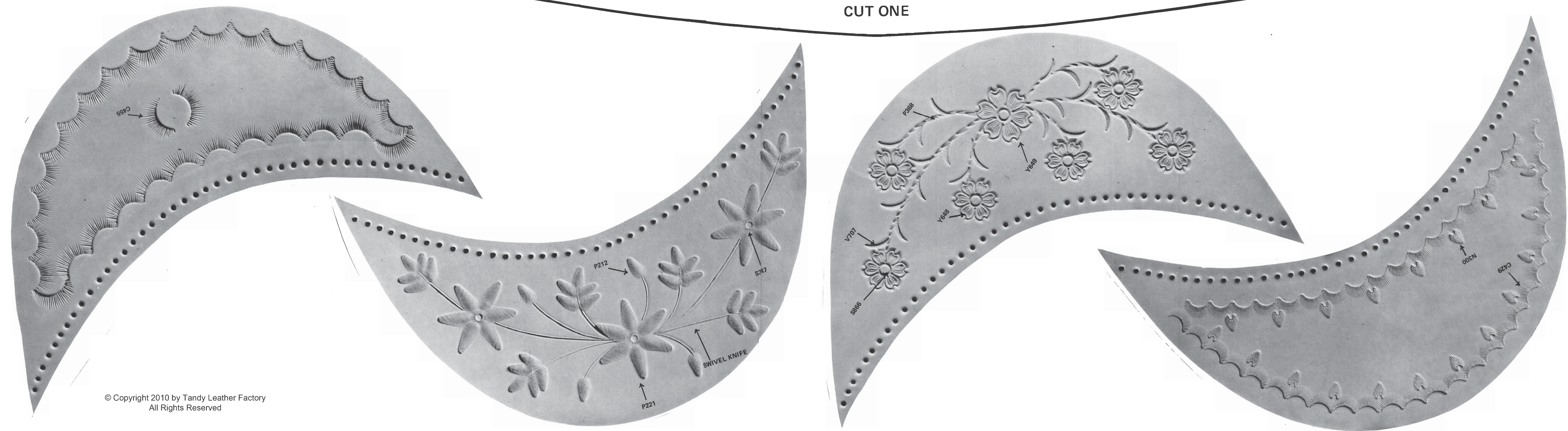
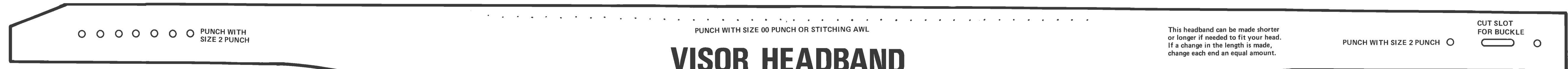

VISOR P



ATTEN



NATURE-TAND DYE

The Nature-Tand dyeing technique allows you to apply dye to the surface of the leather to contrast with the stamped and natural impressions in the leather. With this technique the dye will not enter the stamped impressions. The dyes used are spirit solvent such as Omega Dye.

Step 1: Wrap a length of cloth around a sponge or wooden block several times. Apply dye to the cloth and blot on a paper towel until cloth has enough dye remaining to color only the surface of the leather. If too much dye remains it may run into the impressions. For shading an edge or small area, use a small piece of sponge without a cloth.

Step 2: With the cloth, apply dye to surface of leather, rubbing briskly so a burnished effect is achieved. Apply more dye to cloth as needed, blotting before applying to leather. Dye all edges.

RAPID RIVET SETTING INSTRUCTIONS

ING INSTRUCTIONS

For a distinctive edge, dye the edges and border area along them with dark brown or black.

For a more finished look, the back side of the Nature Tand leather may be dyed with Omega Dye and finished with Omega Carnauba Cream or Omega Finish Coat.

The basic colors recommended are: dark brown, medium brown, tan, light brown, Cordovan, or a combination of red (applied first) and dark brown.

Step 3: After dye has been applied, wait until leather dries before applying a finish. Omega Carnauba Cream or Finish Coat make excellent finishes for this type leather and dye.

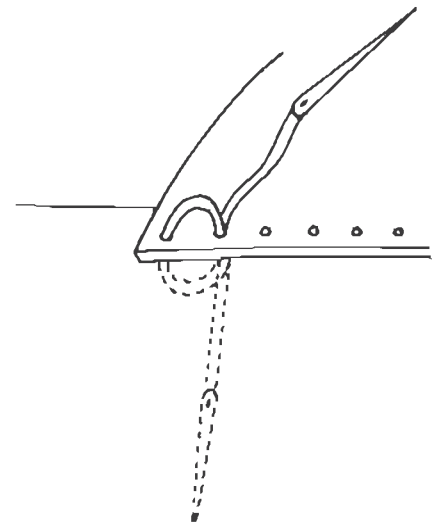

Step 3: Push needle from BACK side thro hole. Use care not to puncture thread wit needle.

HANDSTITCHING INSTRUCTIONS

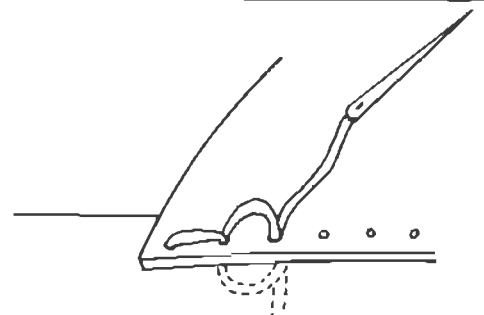

ASSEMBLY INSTRUCTIONS FOR VISOR

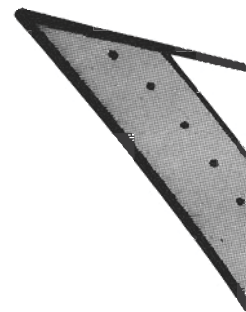

Step 1: Use the cutting patterns to cut the leather parts and punch the holes. Skive the shaded area of the Visor Bill and edge the Visor Bill and Headband. Design the leather with designs of your choice, then dye and finish the parts following the Nature-Tand Dyeing Instructions.



ugh same
h second

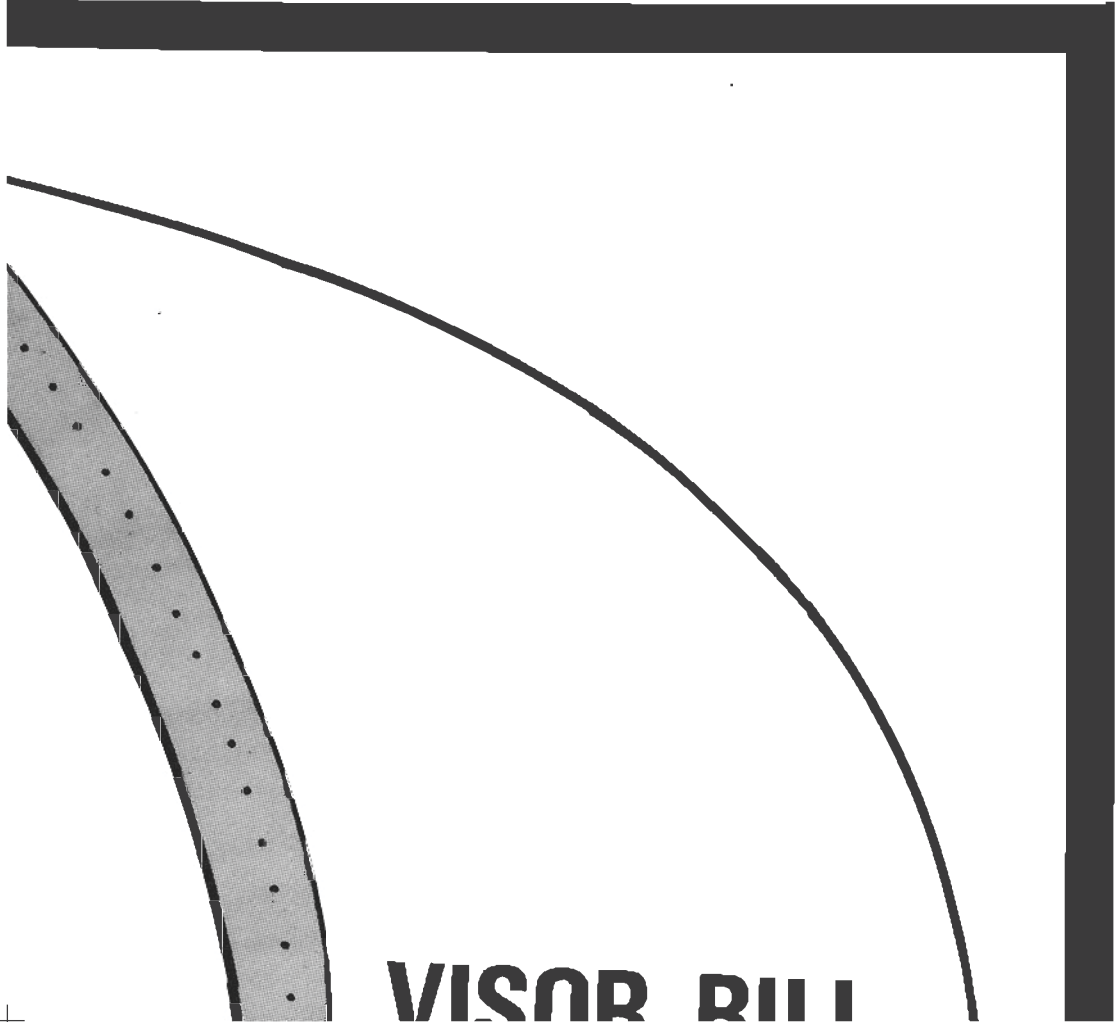

VISOR RII I



MATERIALS NEEDED:

- 7-8 oz. Nature-Tand or Live Oak
- Knife
- Mallet
- Two Size 00 Harness Needles
- 4 ft. Waxed Thread
- Size 2 Punch
- Size 00 Punch or Stitching Awl
- Craftool French Skiving Tool
- Craftool Bevel-eze Edge Beveler
- Size 2 (Optional)
- Craftool Circle Edge Slicker (Optional)
- 1 Medium Rapid Rivet
- Craftool Rivet Setter
- Craftool Leather Stamps (for the design of your choice)
- Omega Dye
- Omega Carnauba Cream or Finish Coat
- 1" Buckle

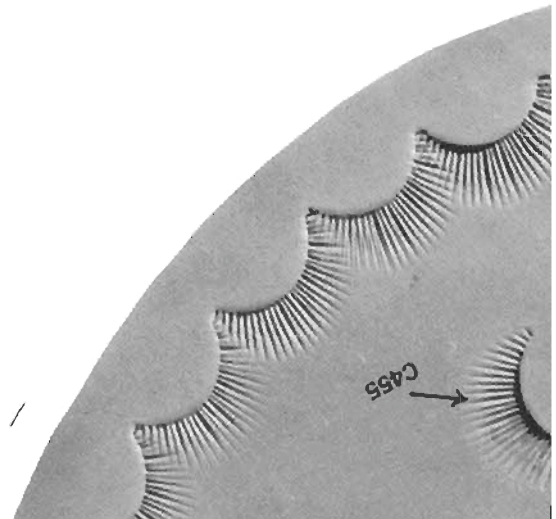



Distributed by
TANDY WAREHOUSE COMPANY
Fort Worth, Texas 76107

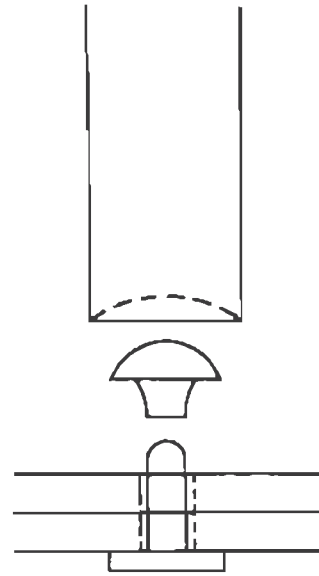

For best results use a rivet setter and rawhide mallet. Use rivet slightly longer than thickness of leathers. Punch hole in leather (use drive or rotary punch) slightly larger than rivet. Place rivet post through leathers and place on hard, smooth, dense surface. Place rivet cap on post. Place concave end of rivet setter on cap (be certain rivet is centered so edges of setter will not mark rivet cap) and tap sharply with rawhide mallet once or twice. Check to see that rivet is set tightly in leather and does not turn.



PUNCH WITH
SIZE 2 PUNCH

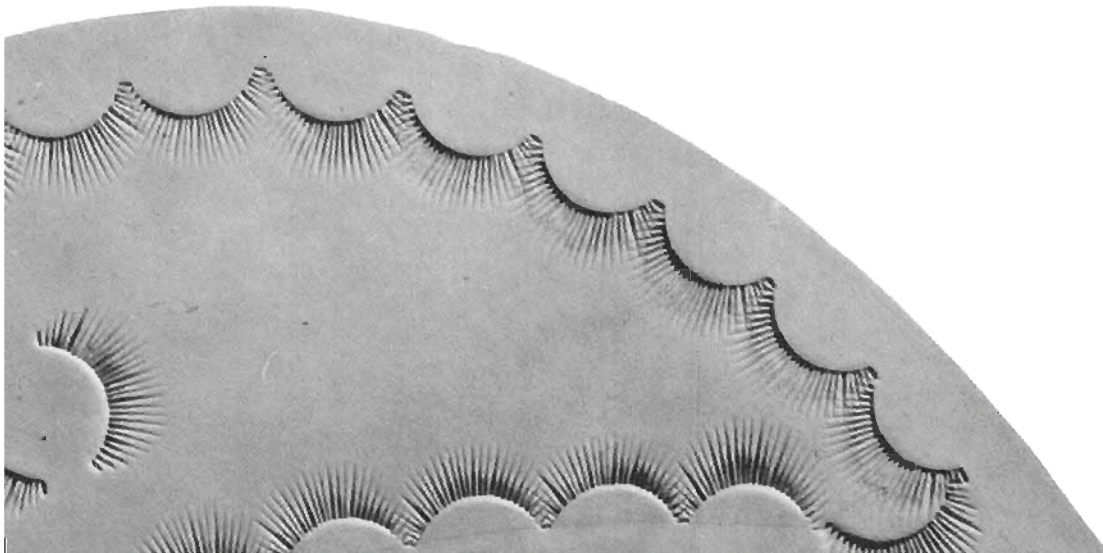

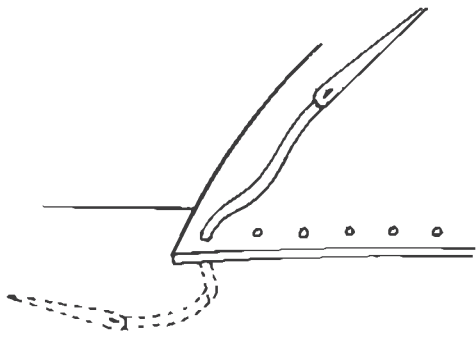

Step 1: Attach needle to each end of waxed thread and push one needle through first hole and pull to center to thread.

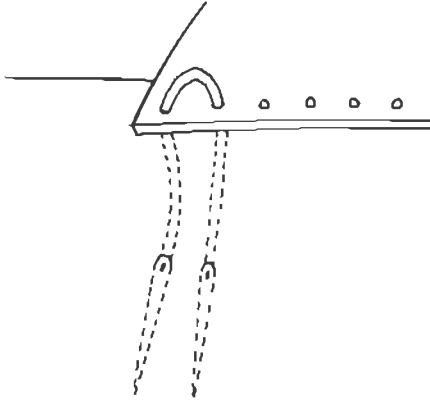

Step 2: Push needle from FRONT side through second hole.

Step 4: Pull stitch tight. Push needle from FRONT through third hole. Push needle from BACK through same hole and pull stitch tight.

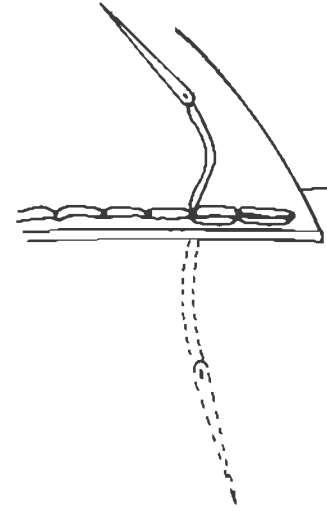

Step 5: To finish off, back stitch through last hole and cut threads off flush with leathers.

(No part of this or any other page may be reproduced without written permission.)

PUNCH WITH SIZE 00 PUNCH OR STITCHER

VISOR HEAD

CUT ONE

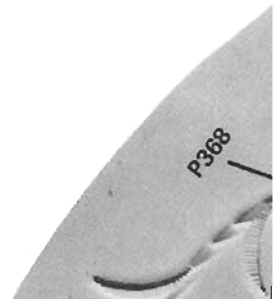
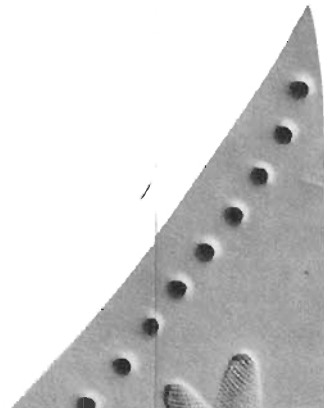

JNT side
CK side

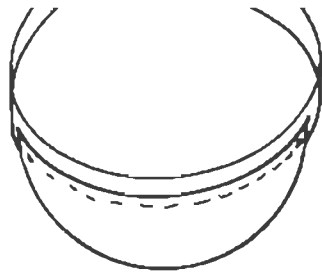

Step 2: Stitch the Visor Bill to the Headband following the Hand Stitching Instructions.

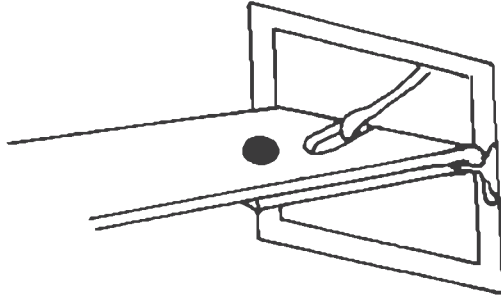

Step 3: Attach the 1" buckle to the headband with a medium Rapid Rivet following the Rapid Rivet Setting Instructions.

two holes

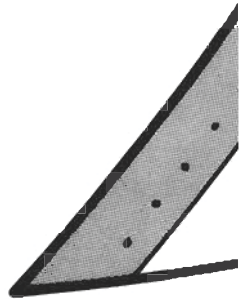

ING AWL

BAND

This headband can be made shorter or longer if needed to fit your head. If a change in the length is made, change each end an equal amount.



WIGGON BILL

CUT ONE

SKIVE SHADED AREA

PUNCH WITH SIZE 00 PUNCH OR STITCHING AWL

PUNCH WITH SIZE 2 PUNCH ○

CUT SLOT FOR BUCKLE



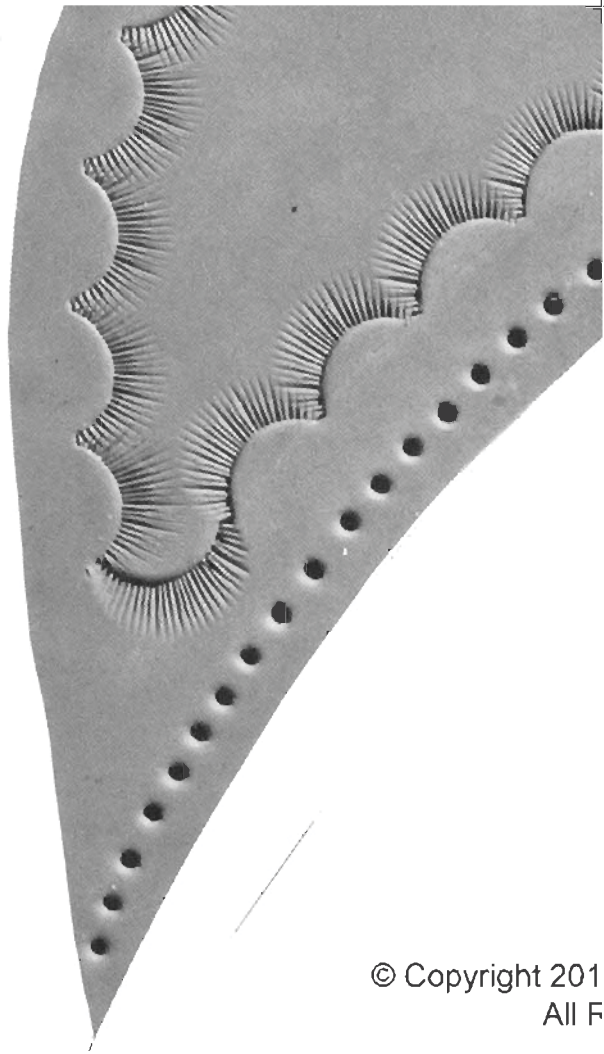

© Copyright 201
All F

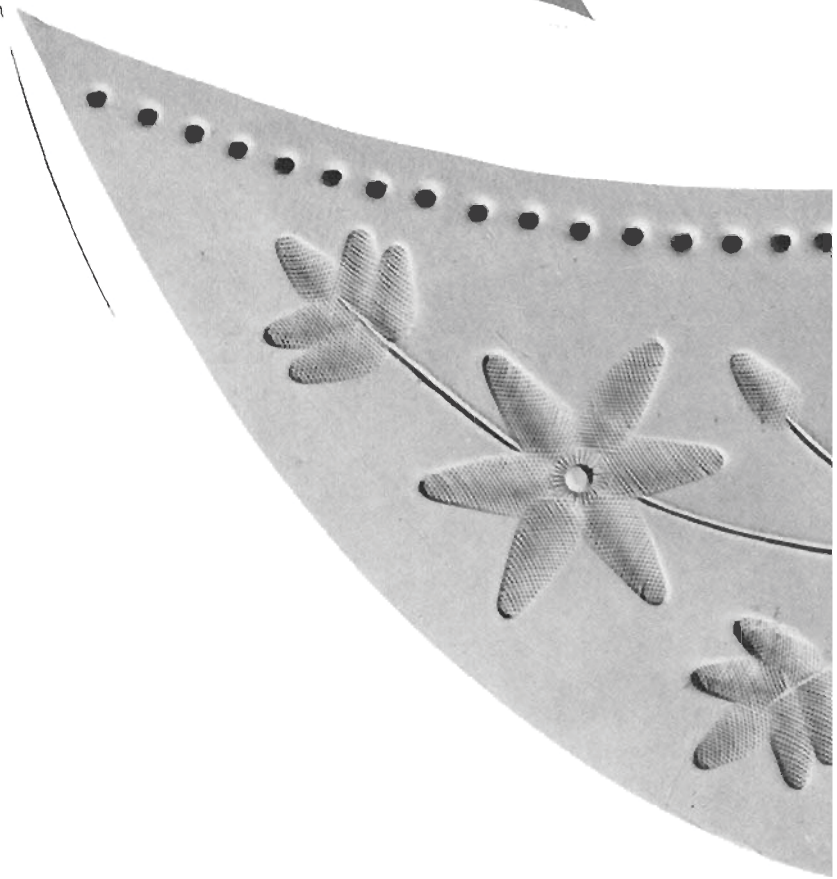
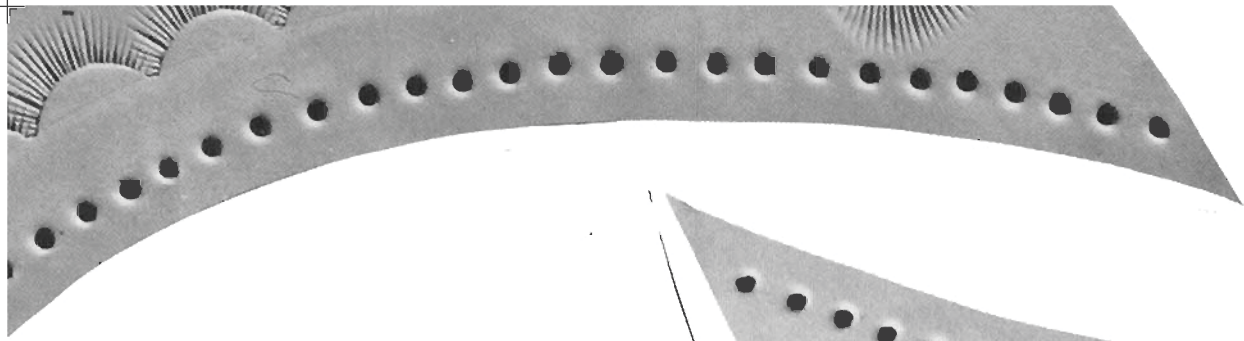

0 by Tandy Leather Factory
ights Reserved









N300

C429