

# Wedge Clog

# PATTERN PAK



This Pattern Pak contains cutting and assembly instructions for the four styles shown above.



# WEDGE SANDALS STYLE A

## Pattern Parts

## Assembly Instructions

NOTE: Cut sole pieces from smaller piece of leather and cut all other pieces from largest piece of leather.

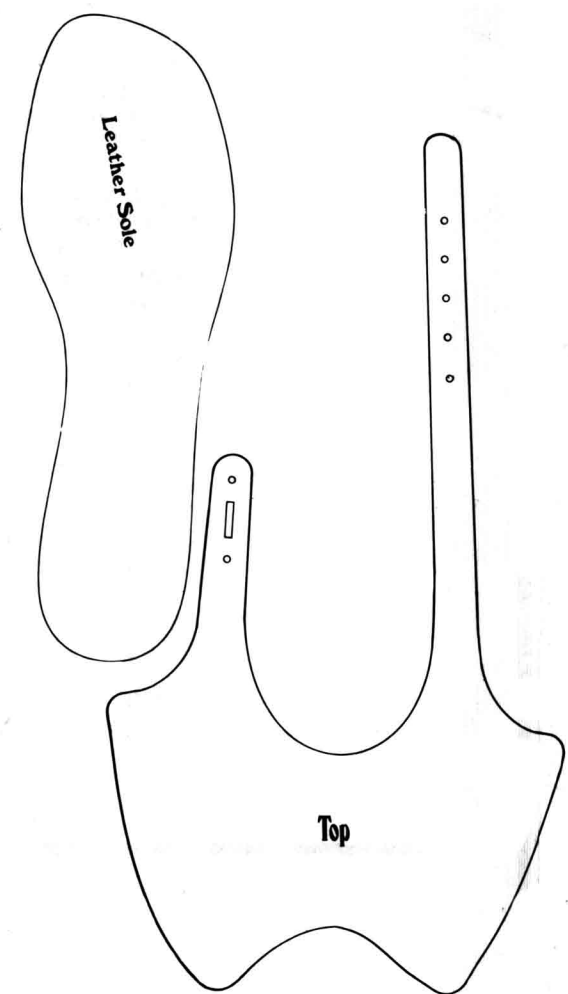

NOTE: Read through all assembly instructions before beginning.

SIZING: After paper pattern pieces have been cut out, hold them to your foot in the proper position, to insure each pattern is large enough before cutting it out of the leather. This is especially important for the top piece, which must come down far enough on the wooden sole, to be secured with tacks. If you find your first size selection is too short, use the next largest size and trim the leather as needed.

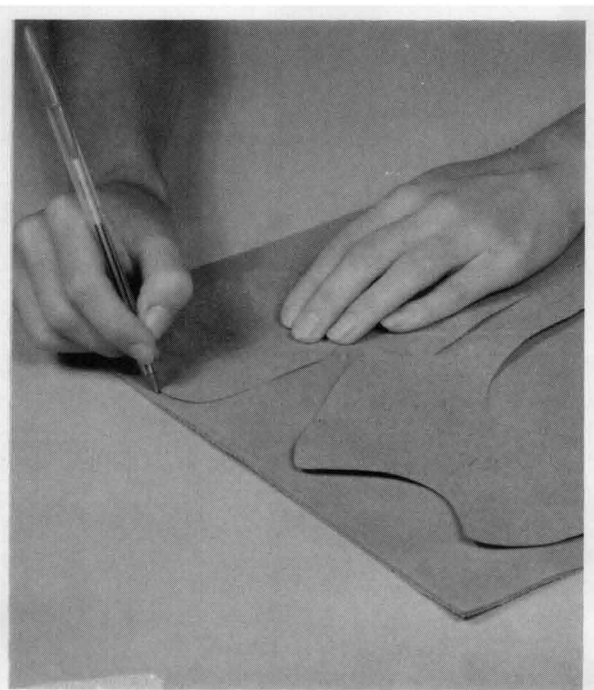

STEP 1: Select the correct size pattern (size indicated on wooden sole) to cut out leather parts. Cut out the paper sole, top and remaining parts with shears. Arrange all the pattern pieces on grain side of leather than trace around them. (See photo.) To make both sole pieces, flip sole pattern and retrace.  
TRACING TIP: Tracing the pattern pieces on the leather will be easier if you make a set of cardboard pattern pieces.



KIT CONTAINS:  
Nature-Tand Leather  
Tacks  
Buckles  
Medium Rapid Rivets  
Cutting and Tooling Patterns  
Assembly Instructions

YOU WILL NEED:  
Craftsman Cement  
Crafts  
Knife  
Hammer  
Orange Dye  
Varnish  
S100 Rivet Setter (optional)  
No. 3 Drive Punch

Distributed by Tandy Warehouse Co.,  
A Division of Tandy Leather Co.  
Fort Worth, Texas

CUT 1 FOR RIGHT SANDAL  
(Flop pattern, CUT 1 for left sandal)  
**Leather Sole  
Size 5**

CUT 1 FOR RIGHT SANDAL  
(Flop pattern, CUT 1 for left sandal)  
**Leather Sole  
Size 7**

CUT 1 FOR RIGHT SANDAL  
(Flop pattern, CUT 1 for left sandal)  
**Leather Sole  
Size 9**

**Leather Sole  
Size 6**

CUT 1 FOR RIGHT SANDAL  
(Flop pattern, CUT 1 for left sandal)

**Leather Sole  
Size 8**

CUT 1 FOR RIGHT SANDAL  
(Flop pattern, CUT 1 for left sandal)

**Leather Sole  
Size 10**

CUT 1 FOR RIGHT SANDAL  
(Flop pattern, CUT 1 for left sandal)



STEP 2: Cut along the traced lines with a sharp knife.



STEP 3: Stain and varnish or just varnish the wooden soles.

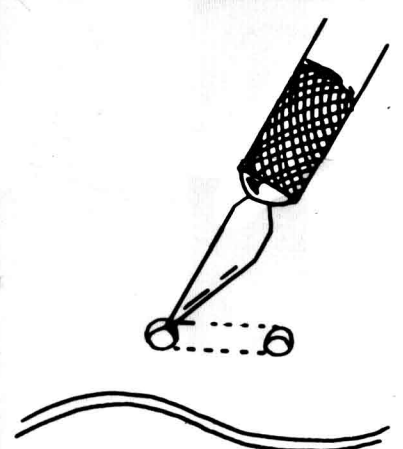

To make slots in leather, use a 3/4" oblong punch or no. 3 punch. If no. 3 punch is used, mark slots on leather using pattern. Punch no. 3 hole at each end of mark, then cut from hole to hole (along dotted lines) as illustrated.

**Top  
Size 10**

CUT 1 FOR RIGHT  
(Flop pattern, CUT 1 for left)

**Top  
Size 8**

CUT 1 FOR RIGHT  
(Flop pattern, CUT 1 for left)

**Top  
Size 6**

CUT 1 FOR RIGHT  
(Flop pattern, CUT 1 for left)

**Top  
Size 9**

CUT 1 FOR RIGHT  
(Flop pattern, CUT 1 for left)

**Top  
Size 7**

CUT 1 FOR RIGHT  
(Flop pattern, CUT 1 for left)

**Top  
Size 5**

CUT 1 FOR RIGHT  
(Flop pattern, CUT 1 for left)

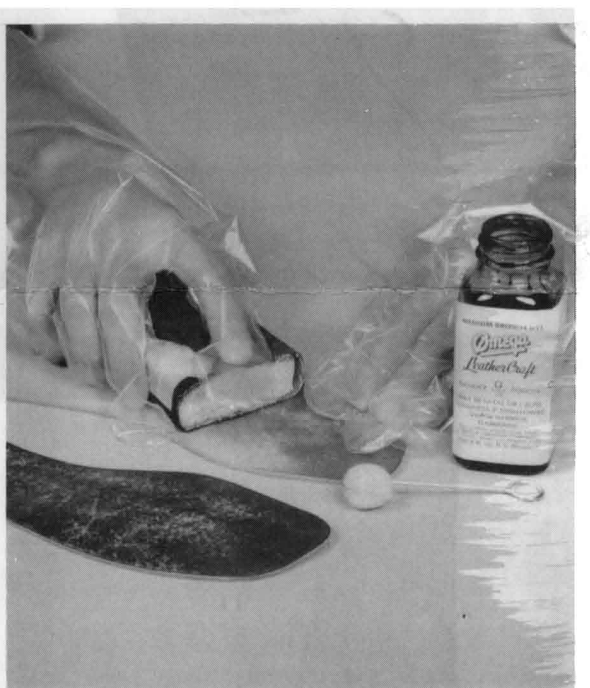

NOTE: Do all carving and stamping before dyeing. (See photo-carve patterns on reverse side of pattern sheet.)  
STEP 4: Using Nature-Tand dyeing technique on reverse side of this sheet, dye the leather parts and then apply Carnuba Cream. Let dry and buff to a shine.

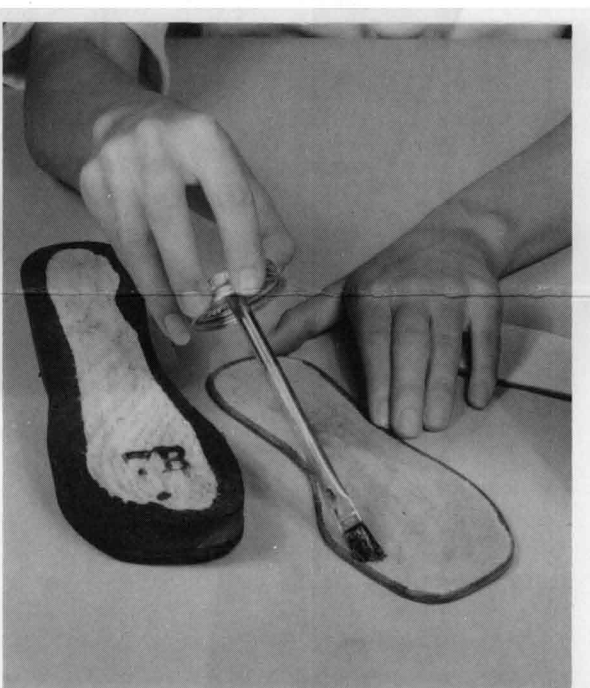

STEP 5: Apply Craftsman Cement to the top of the wooden sole and to flash side of the leather soles. Allow the cement to dry until it becomes tacky.

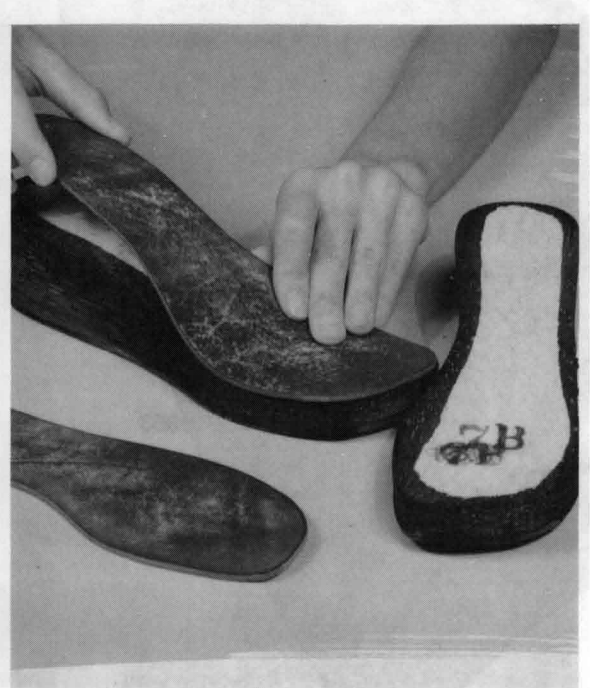

STEP 6: Aligning edges, carefully press the toe of the leather sole to the toe of the wooden sole, with edges aligned at toe-work toward heel. Press leather sole firmly in place. If leather extends off edge of wooden sole, trim with a sharp knife and carefully dye edges again. (Use small brush.)



STEP 7: Insert buckle tongue through slits from grain side of buckle strap; then fold buckle strap around buckle (grain side to grain side) and align rivet holes. Set rapid rivets using rapid rivet instructions on reverse side of sheet. Punch holes in other strap as indicated on pattern.

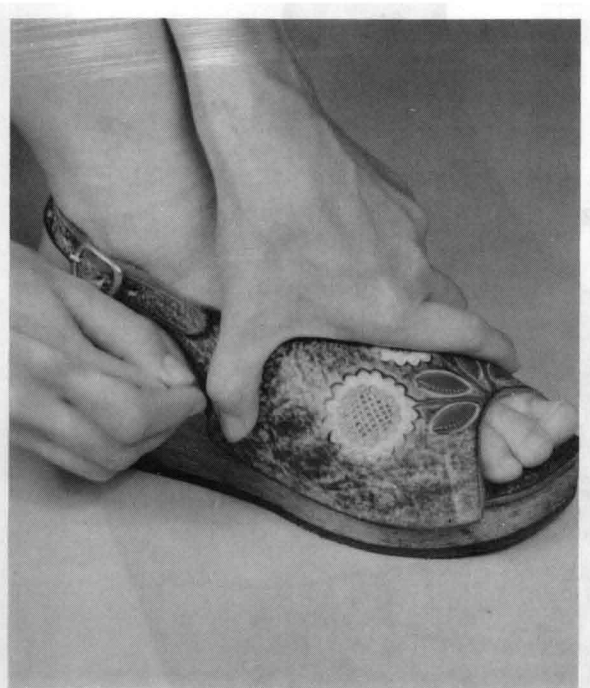

STEP 8: Place your foot on the sole and position leather top across top of foot, as shown. Mark wooden sole lightly with pencil at edge of leather top for placement. Be sure when fitting leather, upper buckle straps are also in place. Top needs to be far enough back for strap to buckle around your heel.



STEP 9: Nail leather top to wooden sole as shown. You may wish to start hole in leather with awl to hold nail in place, while driving nail in place. It's easier if you nail the ends first, then center the middle tack and center last two tacks between the ends and the center tack.  
Repeat steps to make left shoe.

Printed in U.S.A.  
Copyright 1974

(No part of this or any other page may be reproduced without written permission.)

**Tracing  
Patterns**

Flop Tracing Pattern for Left Shoe

© Copyright 2010 by Tandy Leather Factory  
All Rights Reserved

# WEDGE SANDALS STYLE A



Distributed by Tandy Warehouse Co.,  
A Division of Tandy Leather Co.  
Fort Worth, Texas

**KIT CONTAINS:**  
Nature-Tand Leather  
Tacks  
Buckles  
Medium Rapid Rivets  
Cutting and Tooling Patterns  
Assembly Instructions

**YOU WILL NEED:**  
Craftsman Cement  
Crafttools  
Knife  
Hammer  
Omega Dye  
Varnish  
8100 Rivet Setter (optional)  
No. 3 Drive Punch

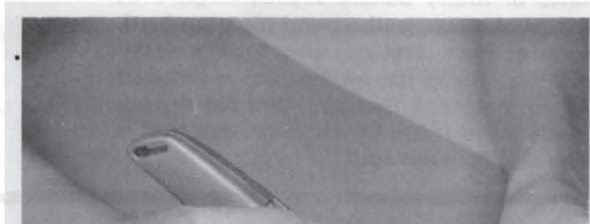

# Pattern Parts

**NOTE:** Cut sole pieces from smaller piece of leather and cut all other pieces from largest piece of leather.

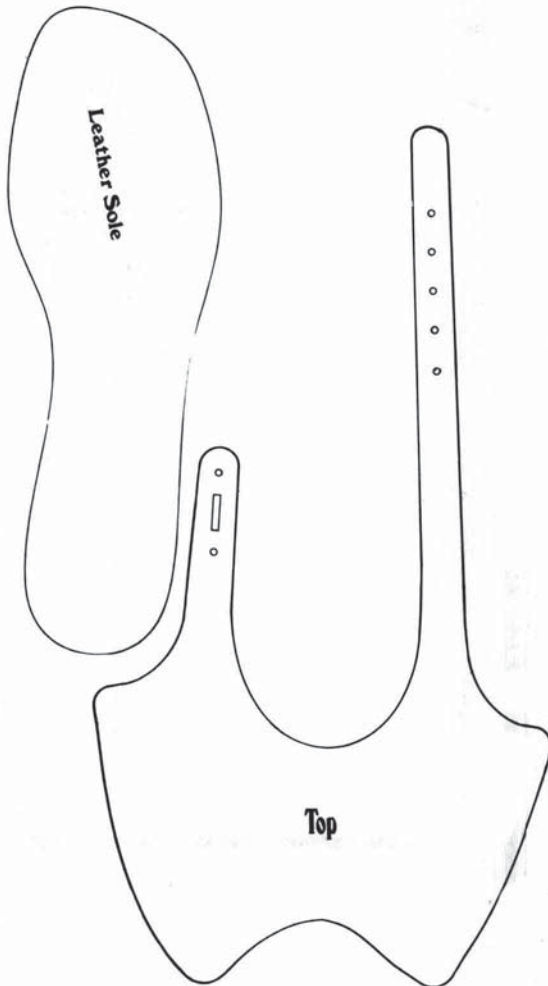

# Assembly Instructions

**NOTE:** Read through all assembly instructions before beginning.

**SIZING:** After paper pattern pieces have been cut out, try them to your foot in the proper position, to insure pattern is large enough before cutting it out of the leather. This is especially important for the top piece, which comes down far enough on the wooden sole, to be secured with tacks. If you find your first size selection is too small, use the next largest size and trim the leather as needed.

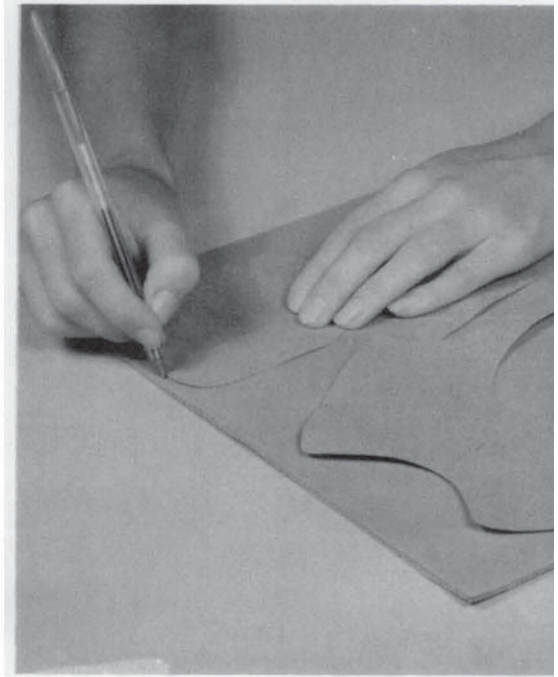

**STEP 1:** Select the correct size pattern (size indicated on wooden soles) to cut out leather parts. Cut out the pattern pieces for the sole, top and remaining parts with shears. Arrange all pattern pieces on grain side of leather then trace around them. (See photo.) To make both sole pieces, flip sole pattern and retrace.

**TRACING TIP:** Tracing the pattern pieces on the leather will be easier if you make a set of cardboard pattern pieces.

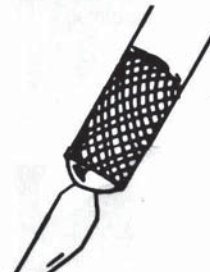

# ions

efore

hold  
each  
ther.  
must  
ured  
hort,



on  
per  
the  
und  
pat-  
will

**CUT 1 FOR RIGHT SANDAL**  
(Flop pattern, CUT 1 for left sandal)

**Leather Sole**  
**Size 5**

**Leather Sole**  
**Size 6**

**CUT 1 FOR RIGHT SANDAL**  
(Flop pattern, CUT 1 for left sandal)



CUT 1 FOR RIGHT SANDAL  
(Flop pattern, CUT 1 for left sandal)

**Leather Sole**  
**Size 7**



CUT 1 FOR RIGHT SANDAL  
(Flop pattern, CUT 1 for left sandal)

**Leather Sole**  
**Size 8**



CUT 1 FOR RIGHT SANDAL  
(Flop pattern, CUT 1 for left sandal)

**Leather Sole**  
**Size 9**

IGHT SANDAL  
T 1 for left sandal)

**er Sole**  
**ze 9**

**Leather Sole**

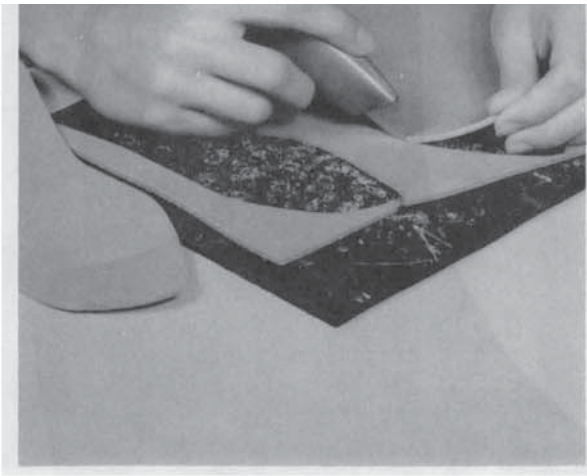

**STEP 2:** Cut along the traced lines with a sharp knife.

ST

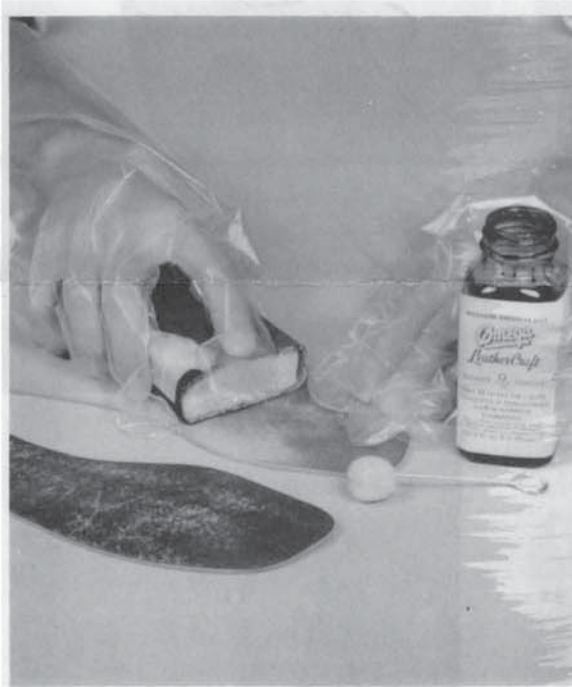

**NOTE:** Do all carving and stamping before dyeing. (See photo-carve patterns on reverse side of pattern sheet.)

**STEP 4:** Using Nature-Tand dyeing technique on reverse side of this sheet, dye the leather parts and then apply Carnauba Cream. Let dry and buff to a shine.

ST  
sol  
to c







STEP 3: Stain and varnish or just varnish the wooden soles.

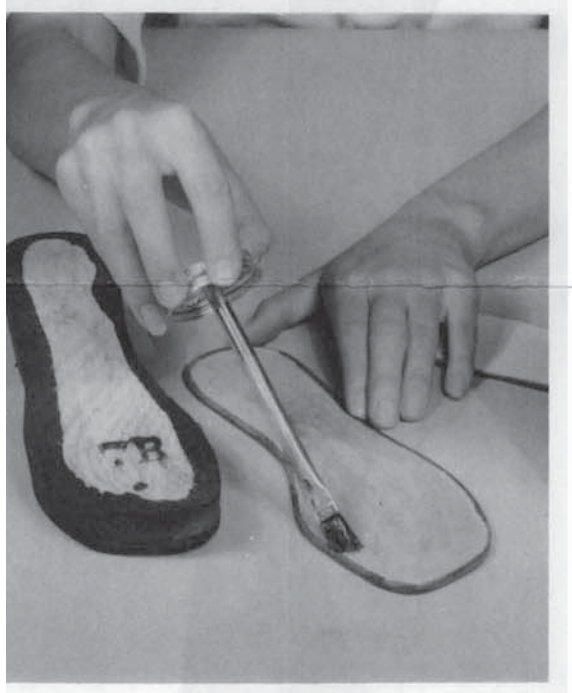

STEP 5: Apply Craftsman Cement to the top of the wooden soles and to flesh side of the leather soles. Allow the cement dry until it becomes tacky.



To make slots in leather, use a 3/4" oblong punch or no. 3 punch. If no. 3 punch is used, mark slots on leather using pattern. Punch no. 3 hole at each end of mark, then cut from hole to hole (along dotted lines) as illustrated.

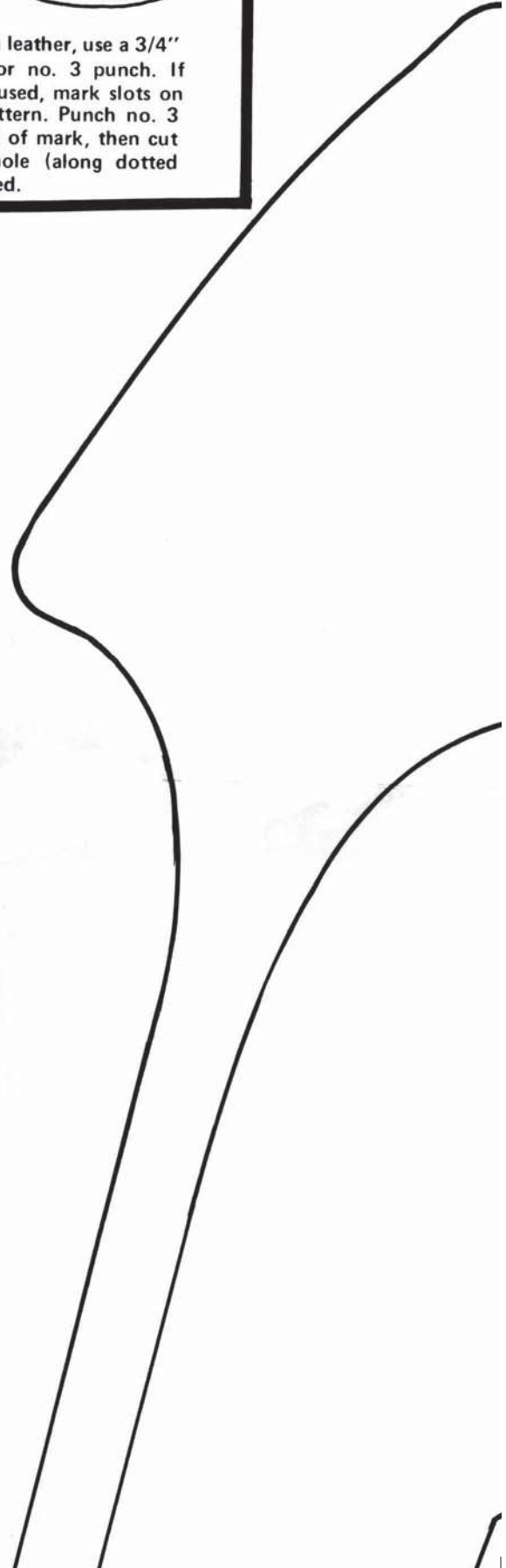

# Top Size 10

CUT 1 FOR RIGHT  
(Flop pattern, CUT 1 for left)



**CUT 1 FOR RIGHT SANDAL**  
(Flop pattern, CUT 1 for left sandal)

**Top**  
**Size 8**

**CUT 1 FOR RIGHT**  
(Flop pattern, CUT 1 for left)

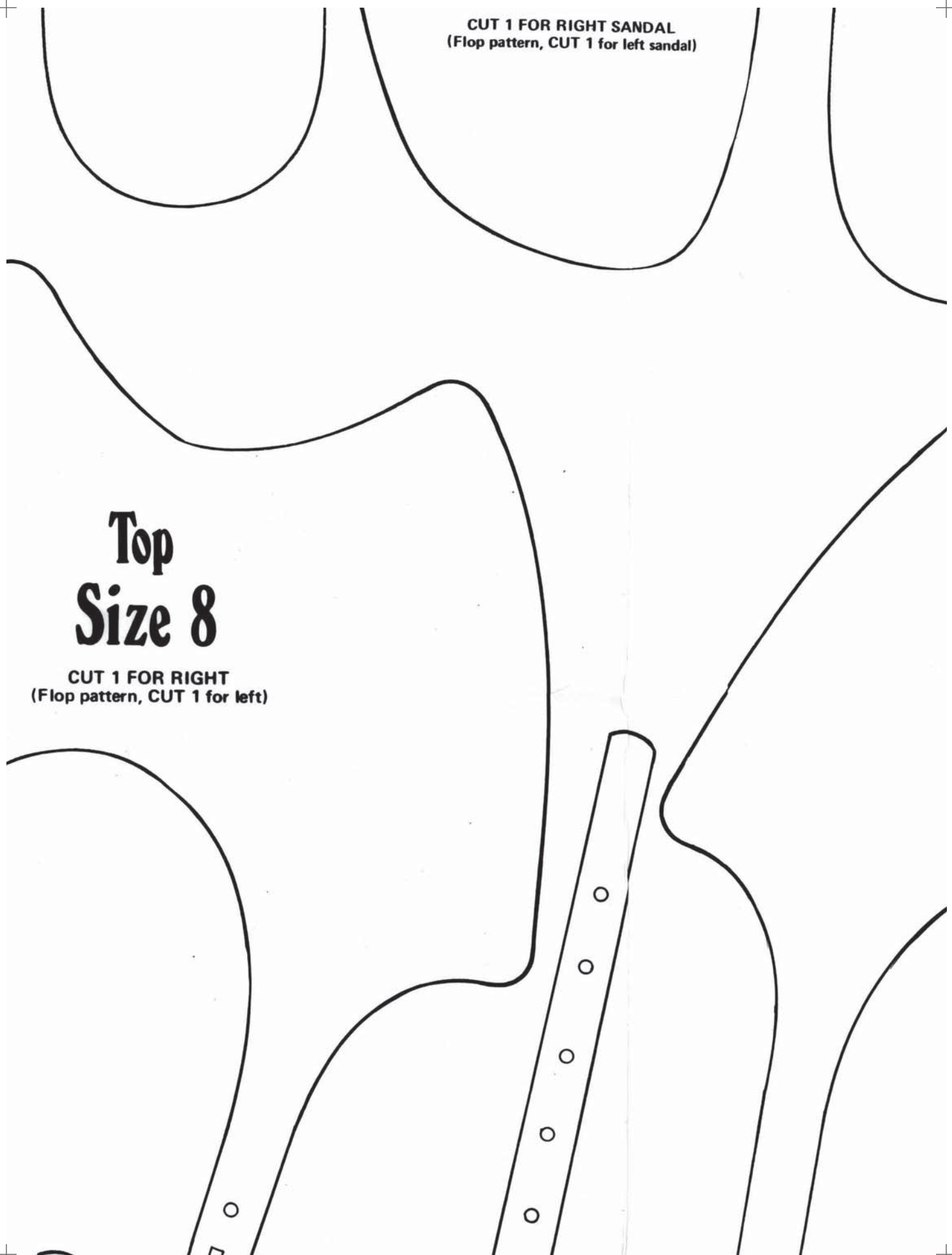

# Size 10

CUT 1 FOR RIGHT SANDAL  
(Flop pattern, CUT 1 for left sandal)

# Top Size 6

CUT 1 FOR RIGHT  
(Flop pattern, CUT 1 for left)

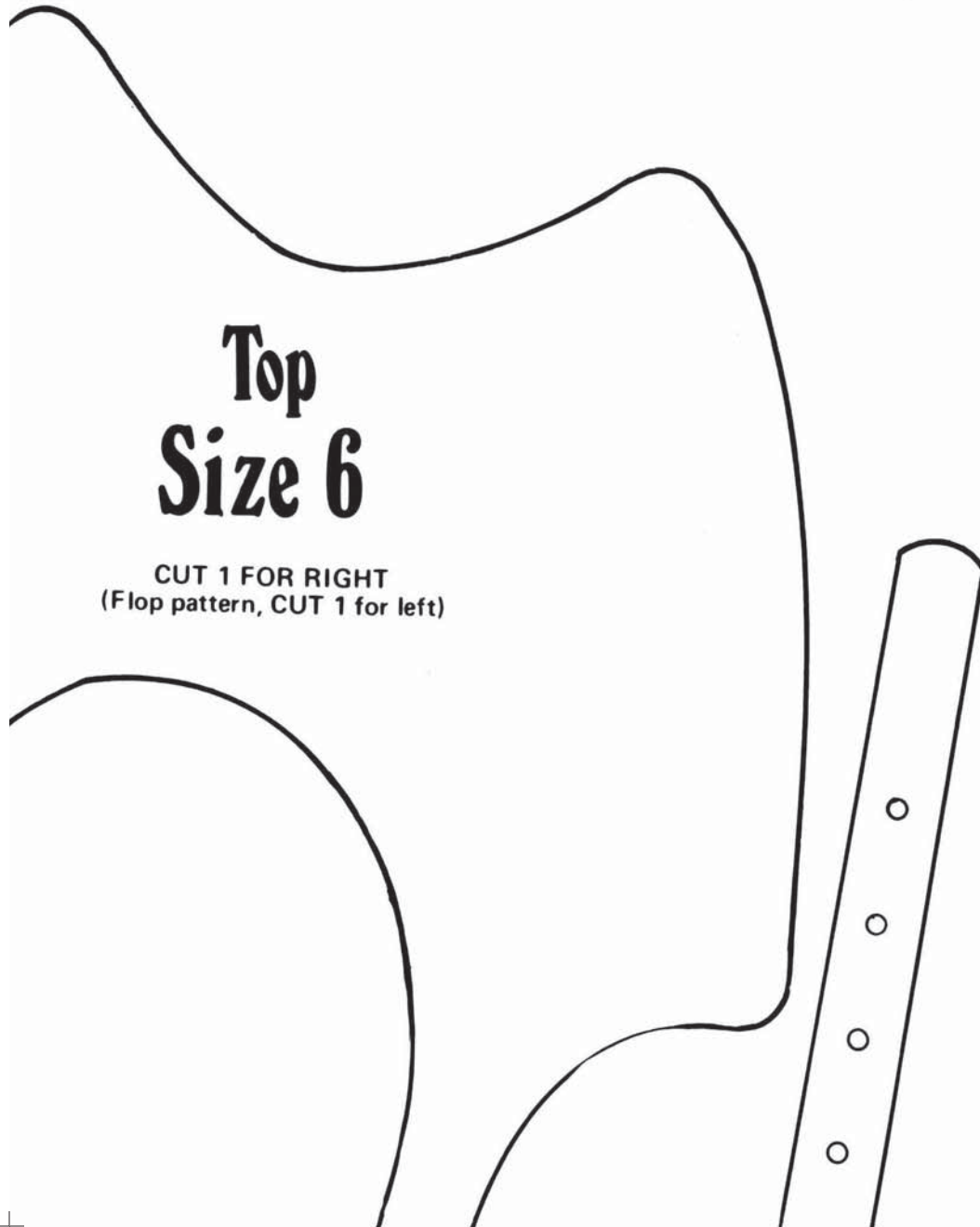
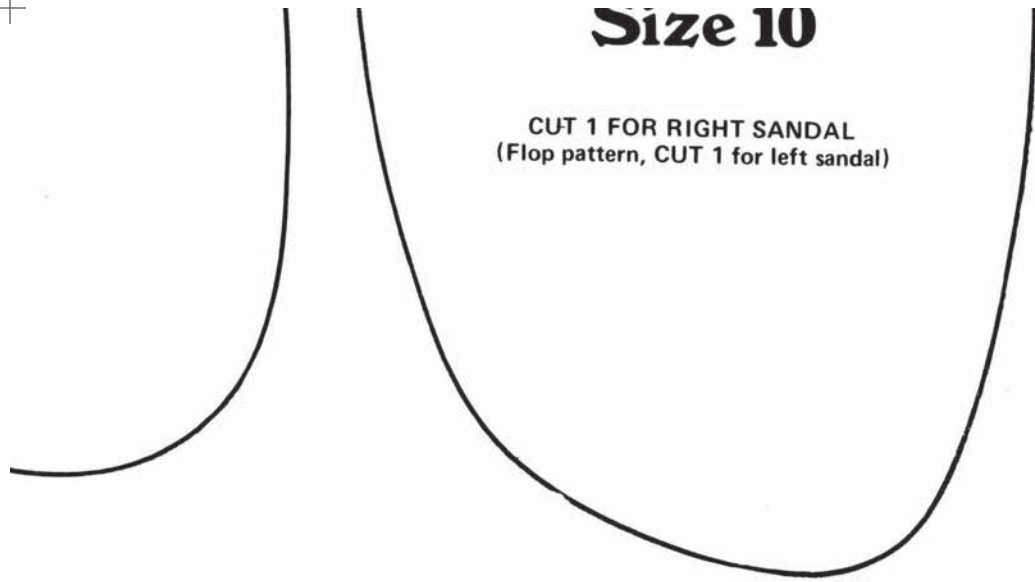



**STEP 6:** Aligning edges, carefully press the toe of the leather sole to the toe of the wooden sole, with edges aligned at toe, work toward heel. Press leather sole firmly in place. If leather extends off edge of wooden sole, trim with a sharp knife and carefully dye edges again. (Use small brush.)

**STE**  
buc  
to g  
rive  
oth

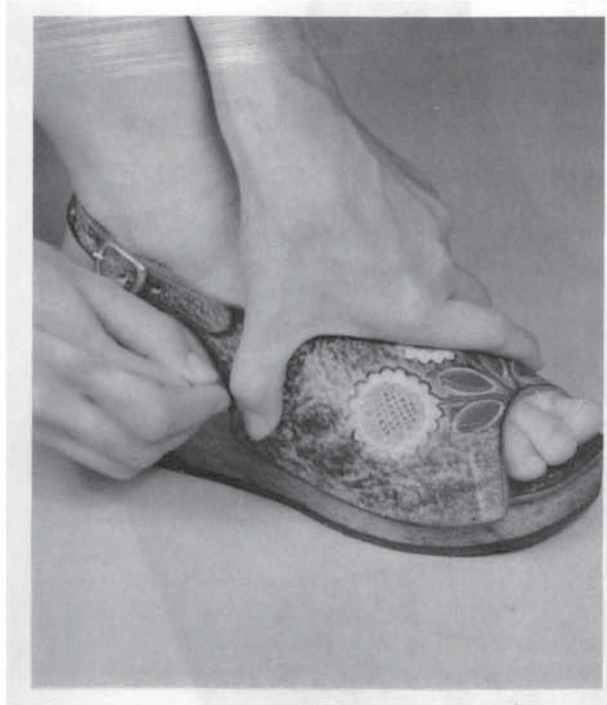

**STEP 8:** Place your foot on the sole and position leather top across top of foot, as shown. Mark wooden sole lightly with pencil at edges of leather top for placement. Be sure when fitting leather, upper buckle straps are also in place. Top needs to be far enough back for strap to buckle around your heel.

**STEI**  
wish  
whil  
then  
twee  
  
Repe

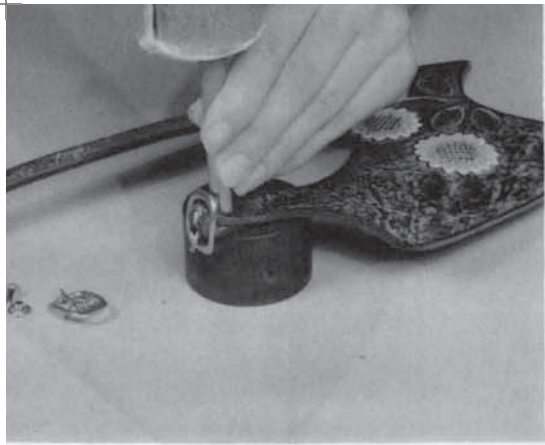

**STEP 7:** Insert buckle tongue through slit from grain side of leather strap; then fold buckle strap around buckle (grain side to grain side) and align rivet holes. Set rapid rivets using rapid rivet instructions on reverse side of sheet. Punch holes in leather strap as indicated on pattern.



**STEP 9:** Nail leather top to wooden sole as shown. You may want to start hole in leather with awl to hold nail in place, then driving nail in place. It's easier if you nail the ends first, then center the middle tack and center last two tacks between the ends and the center tack.

Repeat these steps to make left shoe.

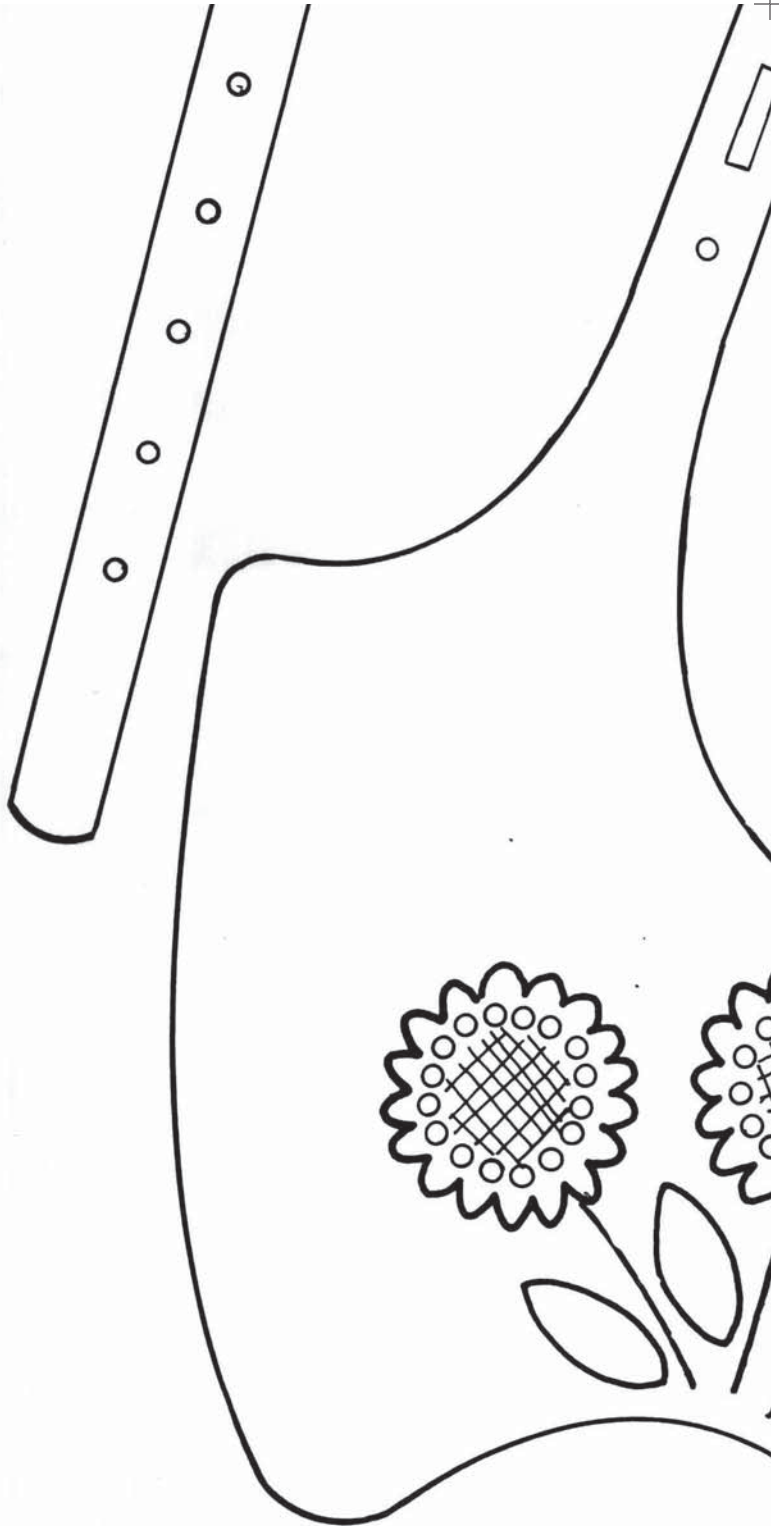

Printed in U.S.A.

Copyright 1974

(No part of this or any other page may be reproduced without written permission.)

# Top Size 9

CUT 1 FOR RIGHT  
(Flop pattern, CUT 1 for left)

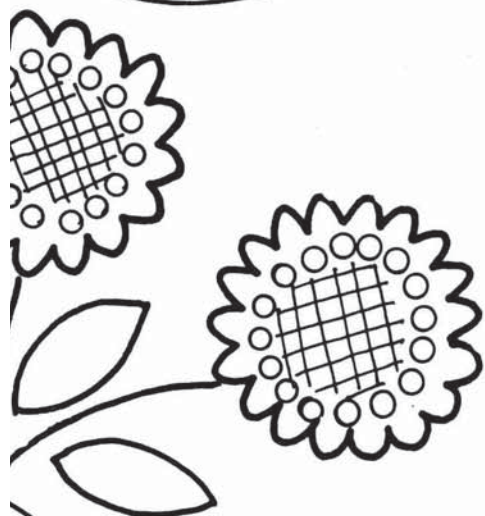

# Tracing Patterns

Flop Tracing Pattern for Left Shoe

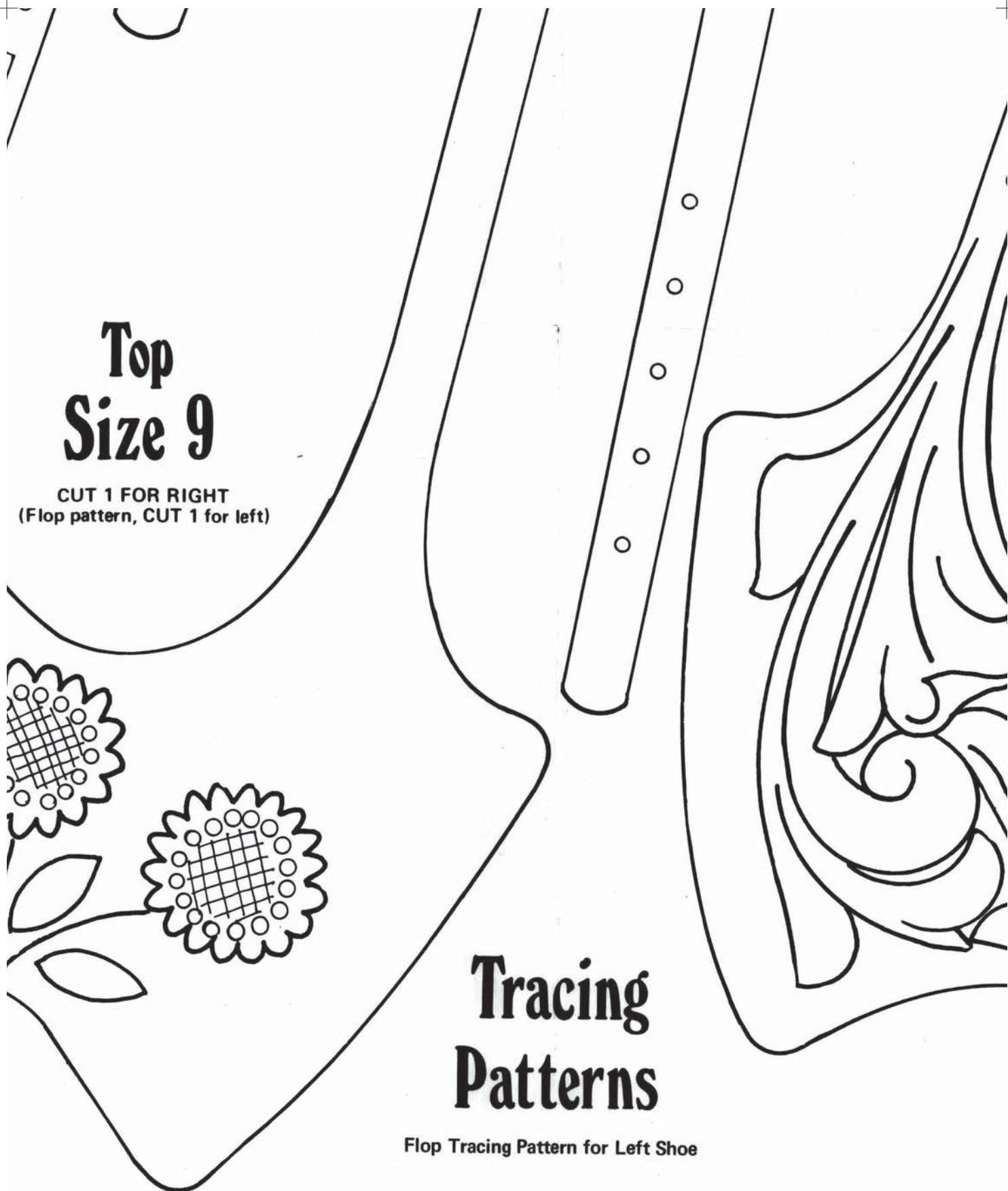



# Top Size 7

CUT 1 FOR RIGHT  
(Flop pattern, CUT 1 for left)





# Top Size 5

**CUT 1 FOR RIGHT**  
(Flop pattern, CUT 1 for left)

# Nature-Tand Dyeing Instructions

The Nature-Tand dyeing technique allows you to apply dye to the surface of the leather to contrast with the stamped and natural impressions in the leather. With this technique the dye will not enter the stamped impressions. The dyes used are spirit solvent such as Omega Dye.

**Step 1.** Wrap a length of cloth around a sponge or wooden block several times. Apply dye to the cloth and blot on a paper towel until cloth has enough dye remaining to color only the surface of the leather. If too much dye remains it may run into the impressions. For shading an edge or small area, use a small piece of sponge without a cloth or a wool dauber.

**Step 2.** With the cloth, apply dye to the surface of the leather, rubbing briskly so a burnished effect is achieved. Apply more dye to cloth as needed, blotting before applying to leather. Dye all edges.

For a distinctive edge, dye the edges and a border area along them with dark brown or black.

For a more finished look, the back side of the Nature-Tand leather may be dyed with Omega dye and finished with Carnauba Cream.

The basic colors recommended are; dark brown, medium brown, tan, a combination of red (applied first) and dark brown, light brown or cordovan.

**Step 3.** Your "nature design" can be enhanced by dyeing flowers and leaves with Cova Dye. Use a small brush.

**Step 4.** After dye has been applied wait until leather dries before applying a finish. Omega Carnauba Cream makes an excellent finish for this type leather and dye.

# Rapid Rivet Instructions

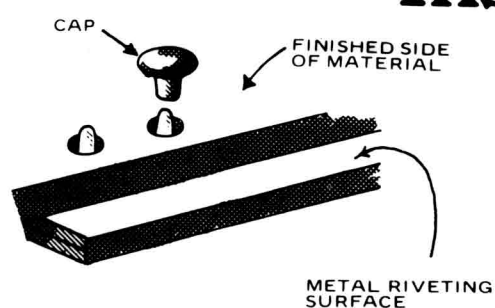

For best results use a rivet setter and rawhide mallet. Use rivet slightly longer than thickness of leathers. Punch hole in leather (use drive or rotary punch) slightly larger than rivet. Place rivet post through leathers and place on hard, smooth, dense surface. Place rivet cap on post. Place concave end of rivet setter on cap (be certain rivet is centered so edges of setter will not mark rivet cap) and tap sharply with rawhide mallet once or twice. Check to see that rivet is set tightly in leather and does not turn.

# Photo Carves

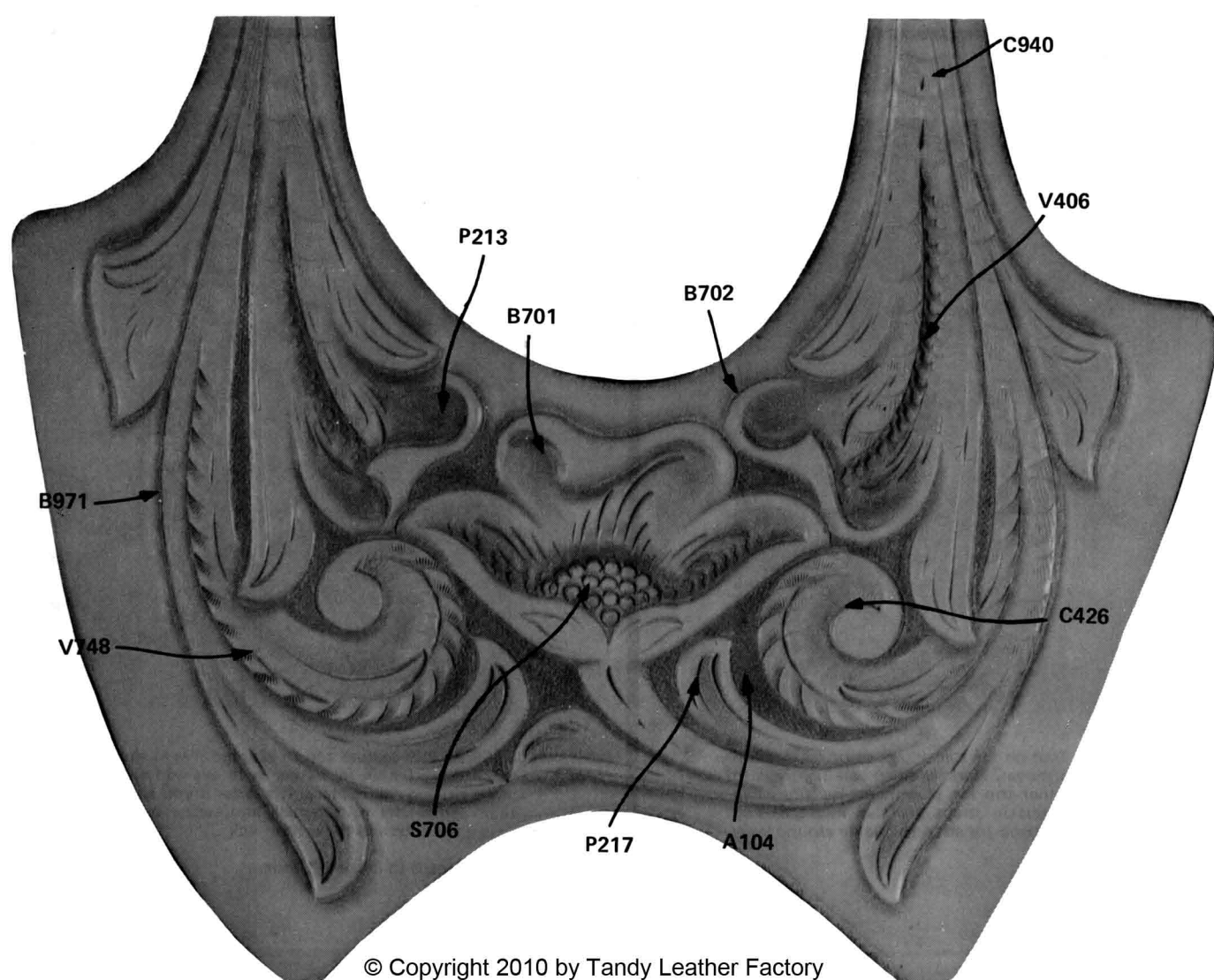
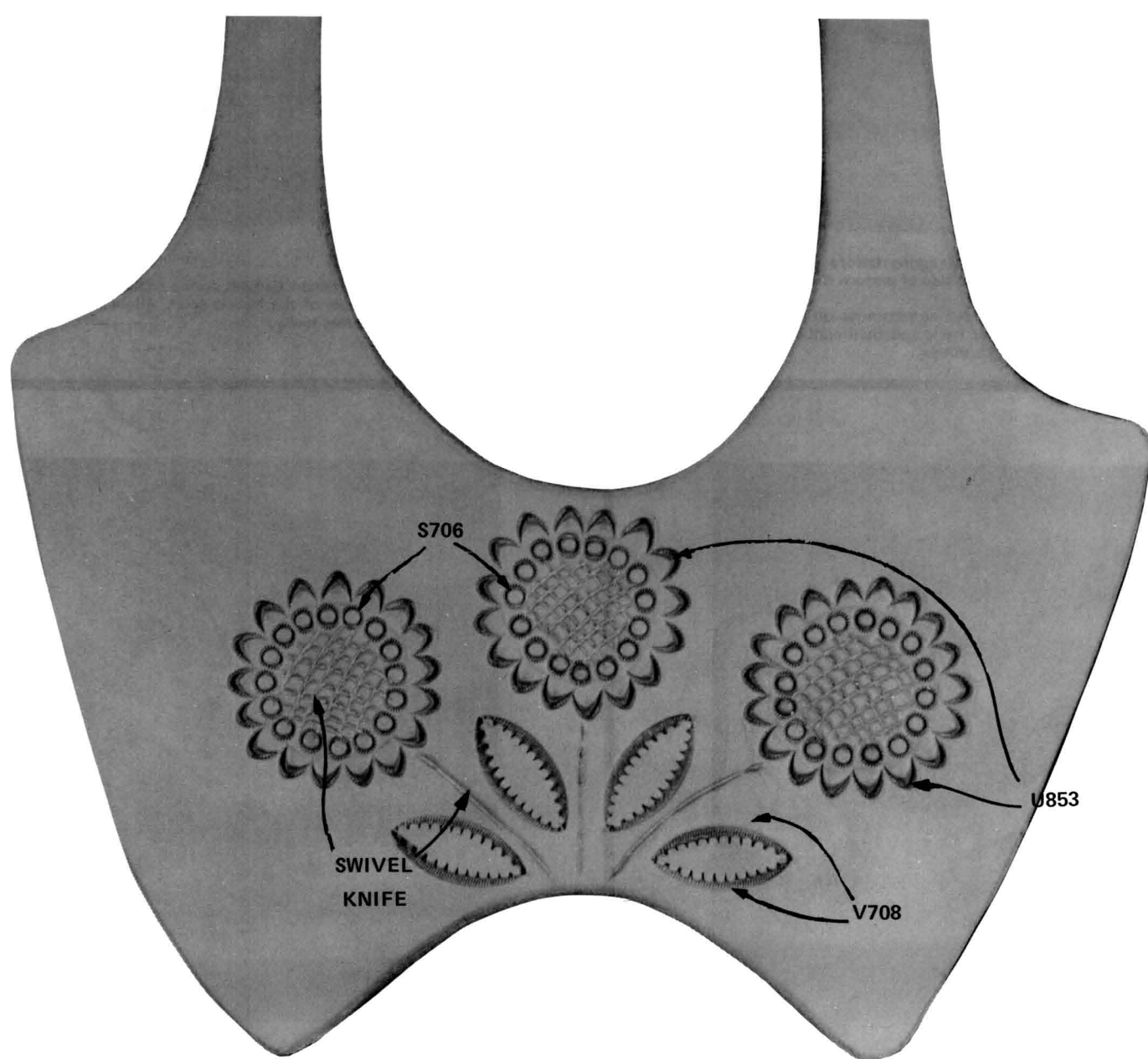
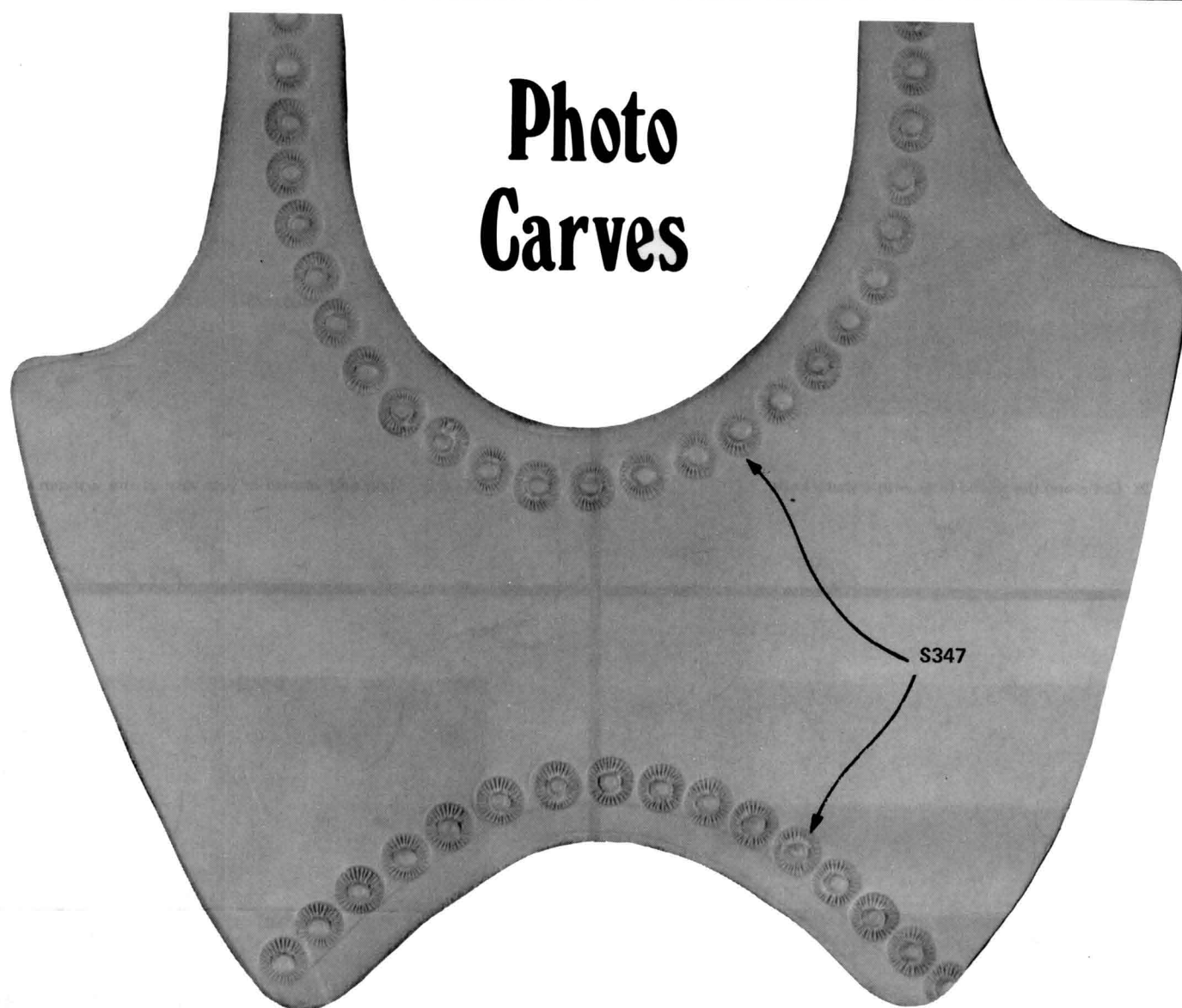

# Nature-Tand Dyeing Instructions

The Nature-Tand dyeing technique allows you to apply dye to the surface of the leather to contrast with the stamped and natural impressions in the leather. With this technique the dye will not enter the stamped impressions. The dyes used are spirit solvent such as Omega Dye.

**Step 1.** Wrap a length of cloth around a sponge or wooden block several times. Apply dye to the cloth and blot on a paper towel until cloth has enough dye remaining to color only the surface of the leather. If too much dye remains it may run into the impressions. For shading an edge or small area, use a small piece of sponge without a cloth or a wool dauber.

**Step 2.** With the cloth, apply dye to the surface of the leather, rubbing briskly so a burnished effect is achieved. Apply more dye to cloth as needed, blotting before applying to leather. Dye all edges.

For a distinctive edge, dye the edges and a border area along them with dark brown or black.

For a more finished look, the back side of the Nature-Tand leather may be dyed with Omega dye and finished with Carnauba Cream.

The basic colors recommended are; dark brown, medium brown, tan, a combination of red (applied first) and dark brown, light brown or cordovan.

**Step 3.** Your "nature design" can be enhanced by dyeing flowers and leaves with Cova Dye. Use a small brush.

**Step 4.** After dye has been applied wait until leather dries before applying a finish. Omega Carnauba Cream makes an excellent finish for this type leather and dye.

# Rapid Rivet Instructions

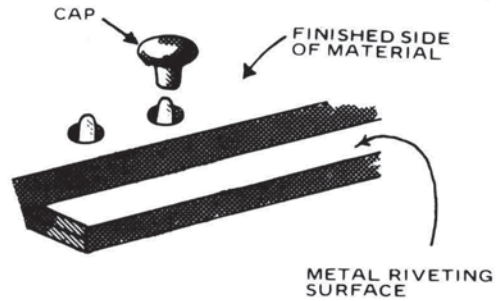

For best results use a rivet setter and rawhide mallet. Use rivet slightly longer than thickness of leathers. Punch hole in leather (use drive or rotary punch) slightly larger than rivet. Place rivet post through leathers and place on hard, smooth, dense surface. Place rivet cap on post. Place concave end of rivet setter on cap (be certain rivet is centered so edges of setter will not mark rivet cap) and tap sharply with rawhide mallet once or twice. Check to see that rivet is set tightly in leather and does not turn.

## Photo Carves

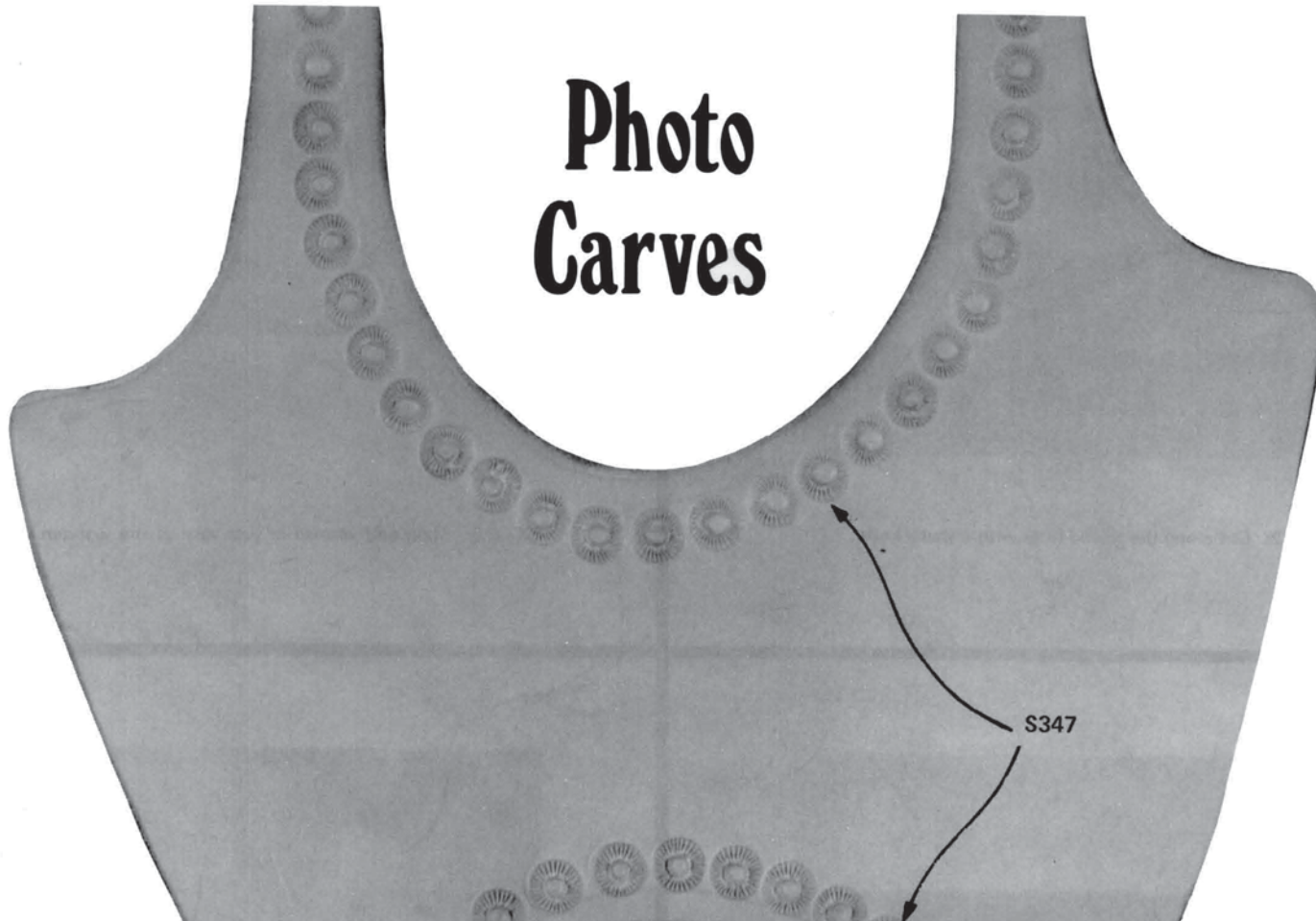



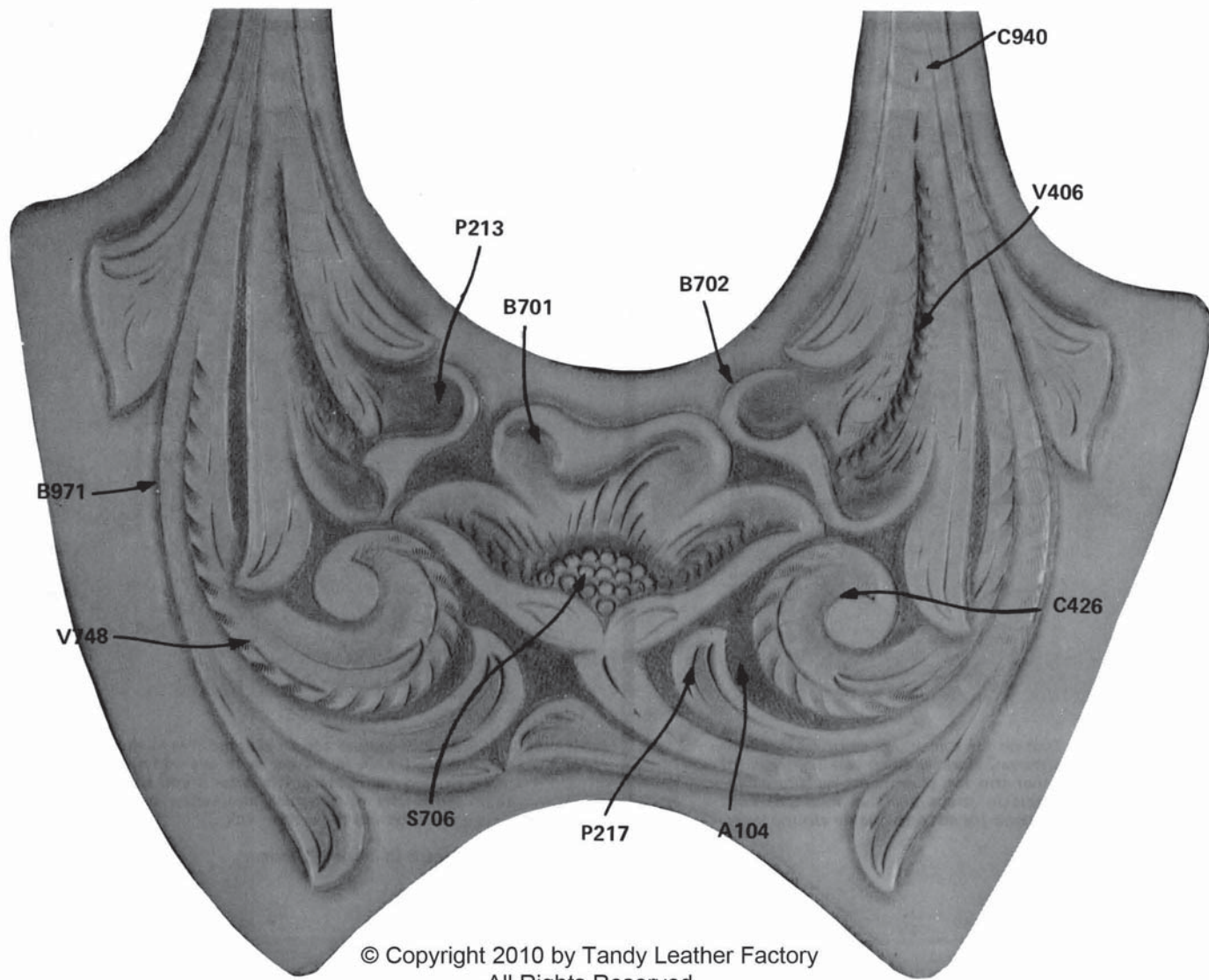

© Copyright 2010 by Tandy Leather Factory  
All Rights Reserved

# Wedge Sandal Style B



**KIT CONTAINS:**  
Nature-Tand Leather  
Tacks  
Buckles  
Medium Rapid Rivets  
Cutting and Pattern Sheets  
Assembly Instructions

**YOU WILL NEED:**  
Craftsman Cement  
Knife  
Hammer  
Omega Dye  
Varnish  
8100 Rivet Setter (optional)  
#3 Drive Punch

Distributed by Tandy Warehouse Co.,  
A Division of Tandy Leather Co.,  
Fort Worth, Texas

## Pattern Parts

NOTE: Cut sole pieces from smaller piece of leather and cut all other pieces from largest piece of leather.

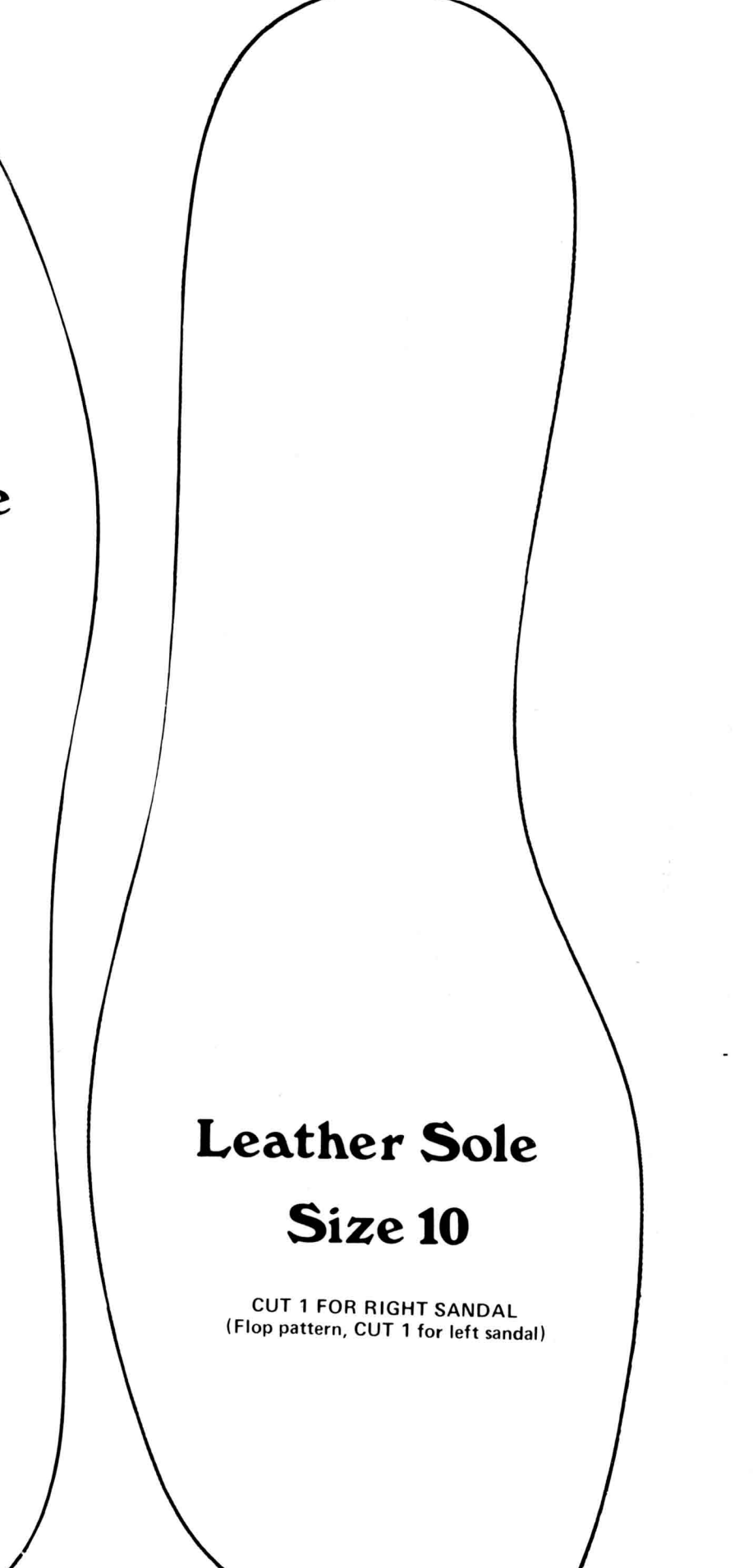
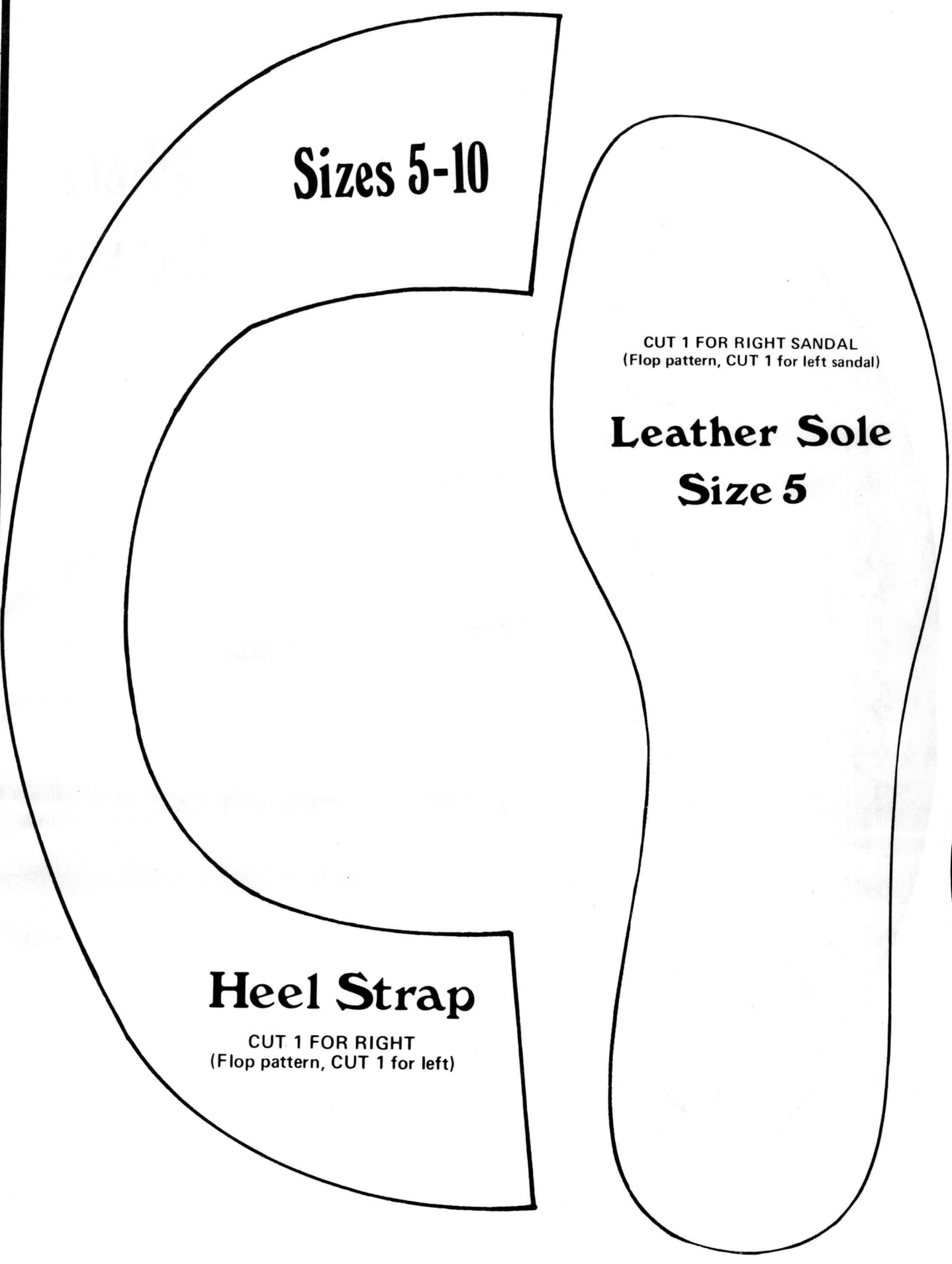
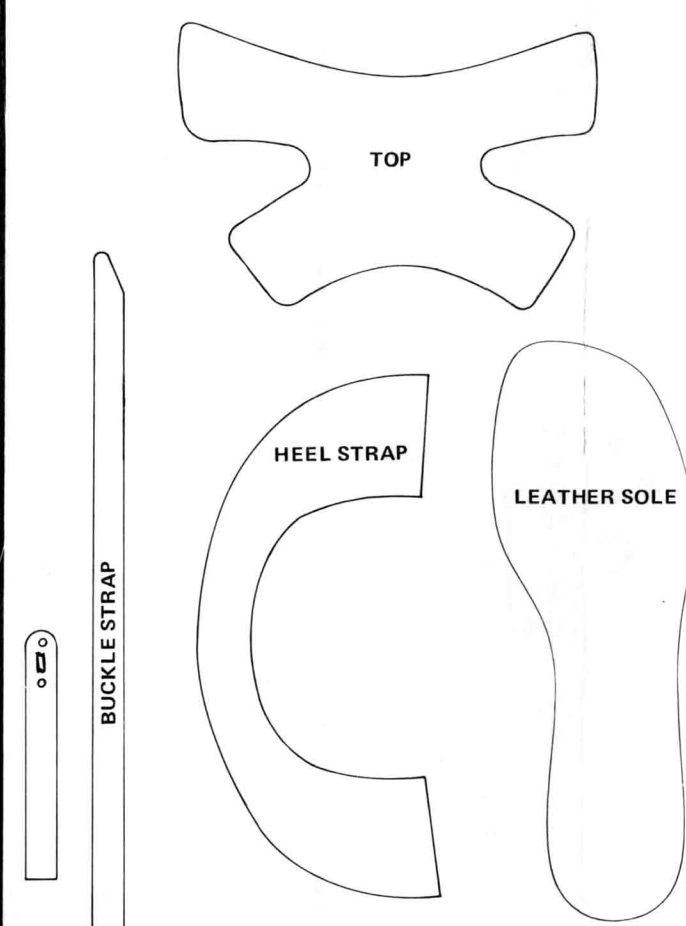

## Assembly Instructions

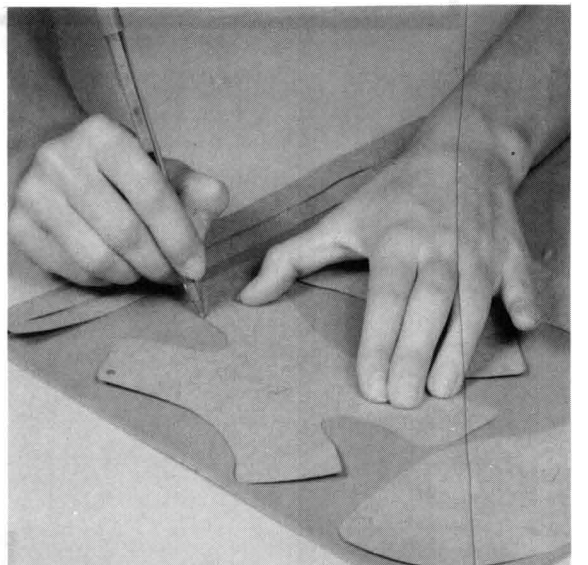

NOTE: Read through all assembly instructions before beginning.

**SIZING:** After paper pattern parts have been cut out, hold them to your foot, in the proper position, to insure each pattern is large enough before cutting it out of the leather. This is especially important for the top piece, which must come down far enough on the wooden sole to be secured with tacks. If you find your first size selection is too short, use the next largest size and trim the leather as needed.

**STEP 1:** Select the correct size patterns (size indicated on wooden soles) to cut leather sole parts. Cut out the paper sole top and remaining parts with shears. Arrange all the pattern parts on grain side of leather and trace around them. (See photo.) To make both sole pieces, flop sole pattern and retrace.

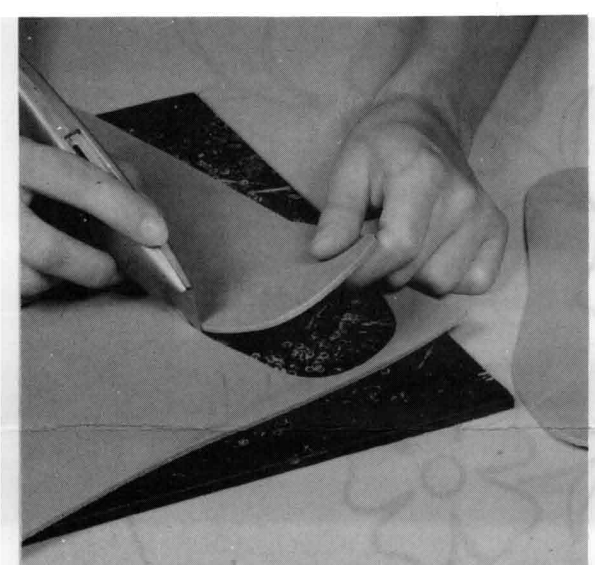

**TRACING TIP:** Tracing the pattern on the leather will be easier if you make a set of cardboard patterns.

**STEP 2:** Cut along the traced lines with a sharp knife.



**STEP 3:** Stain and varnish or just varnish the wooden soles.



NOTE: Do all carving and stamping before dyeing. (See photo-carve patterns on back of sheet.)

**STEP 4:** Using Nature-Tand dyeing technique on back of this sheet, dye the leather parts and then apply Caruba Cream. Let dry and buff to a shine.



**STEP 5:** Apply Craftsman Cement to the top of the wooden soles and to the back side of the leather soles. Allow to dry until it becomes tacky.



**STEP 6:** Aligning edges; carefully press the toe of the leather sole to the toe of the wooden sole, with edges aligned at toe, work toward the heel. Press leather sole firmly in place. If leather extends off edge of wooden sole, trim with a sharp knife and carefully dye edges again. (Use small brush.)



**STEP 7:** Place your foot on the sole and position leather top across top of foot, as shown. Mark wooden sole, lightly, with a pencil around edges of leather top for placement.

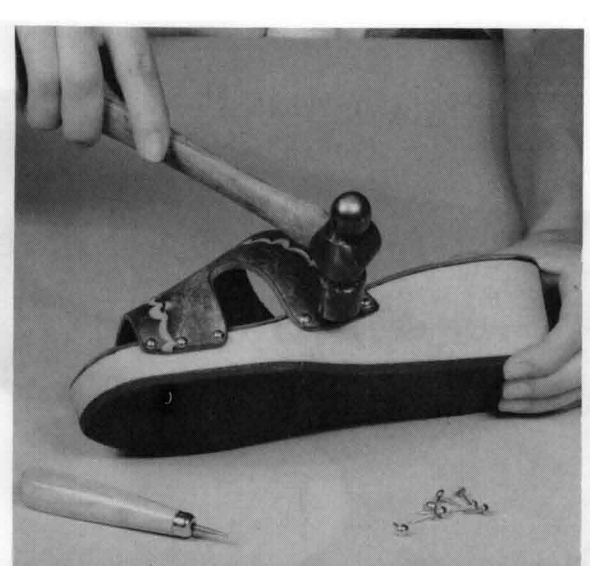

**STEP 8:** Nail leather top to wooden sole, as shown, using three tacks on each strap.



**STEP 9:** Punch holes in end of straps as indicated on pattern. Insert buckle tongue through slit from grain side of buckle strap, fold buckle strap around buckle (grain side to grain side) and align rivet holes. Set rapid rivets using rapid rivet instructions on back of this sheet.



**STEP 10:** Place heel strap around heel in a comfortable position. With a pencil, mark where the strap should be trimmed. Leather should come down on wooden sole far enough for nails to catch both. Trim and dye edges.

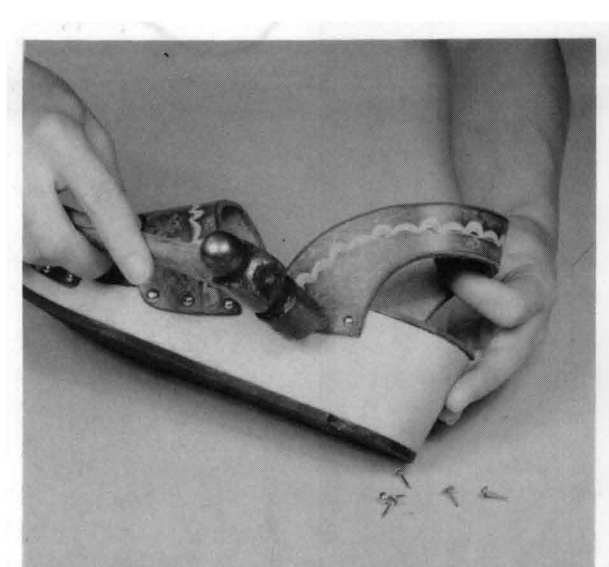

**STEP 11:** Place foot in sandal and pull heel strap until comfortable. Now position ends of heel strap on wooden sole, mark on wooden sole and nail in place.

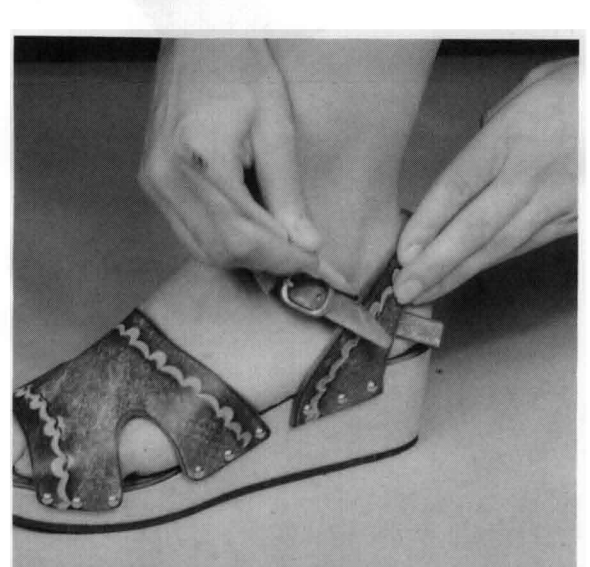

**STEP 12:** Attach top strap to buckle strap through second hole to make one unit. Place unit over foot as shown. Mark and cut off excess leather, dye edges.



**STEP 13:** Punch holes in ends of buckle strap and in background then rivet back strap to buckle strap (see rapid rivet instructions on back of sheet) on both sides.

## Rapid Rivet Instructions

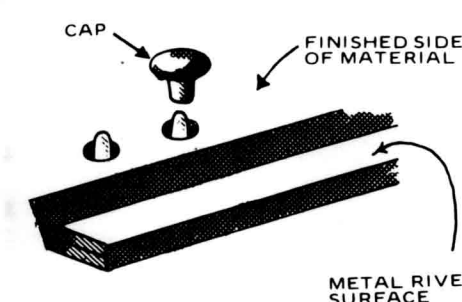

For best results use a rivet setter and rawhide mallet. Use rivet slightly longer than thickness of leathers. Punch hole in leather (use drive or rotary punch) slightly larger than rivet. Place rivet post through leathers and place on hard, smooth, dense surface. Place rivet cap on post. Place concave end of rivet setter on cap (be certain rivet is centered so edges of setter will not mark rivet cap) and tap sharply with rawhide mallet once or twice. Check to see that rivet is set tightly in leather and does not turn.

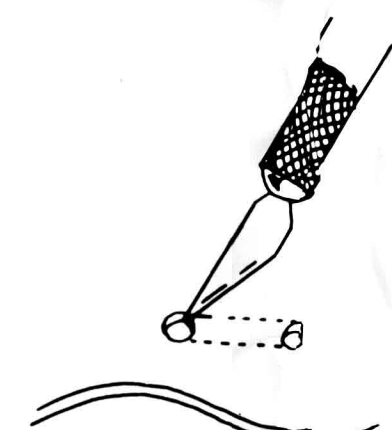

To make slots in leather, use a 3/4" oblong punch or no. 3 punch. If no. 3 punch is used, mark slots on leather using pattern. Punch no. 3 hole at each end of mark, then cut from hole to hole (along dotted lines) as illustrated.

## "Nature" Designs

"Nature designs" may be stamped on your leather projects, with the use of leather stamps many different designs can be created by using your own perception of objects around you in "nature".

As you develop an awareness of "nature designs" and begin transferring them from your mind to the leather surface with leather tools, you will enjoy a most gratifying experience. From the simple smooth lined to the most intricate of details, you can express your own impressions of visual and emotional experiences.

You may wish to simply dye and finish your project. Either way, you can "go back to nature" making your own custom leather items.

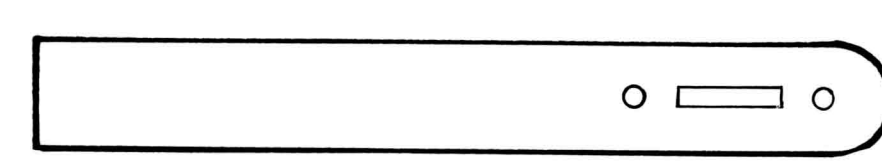
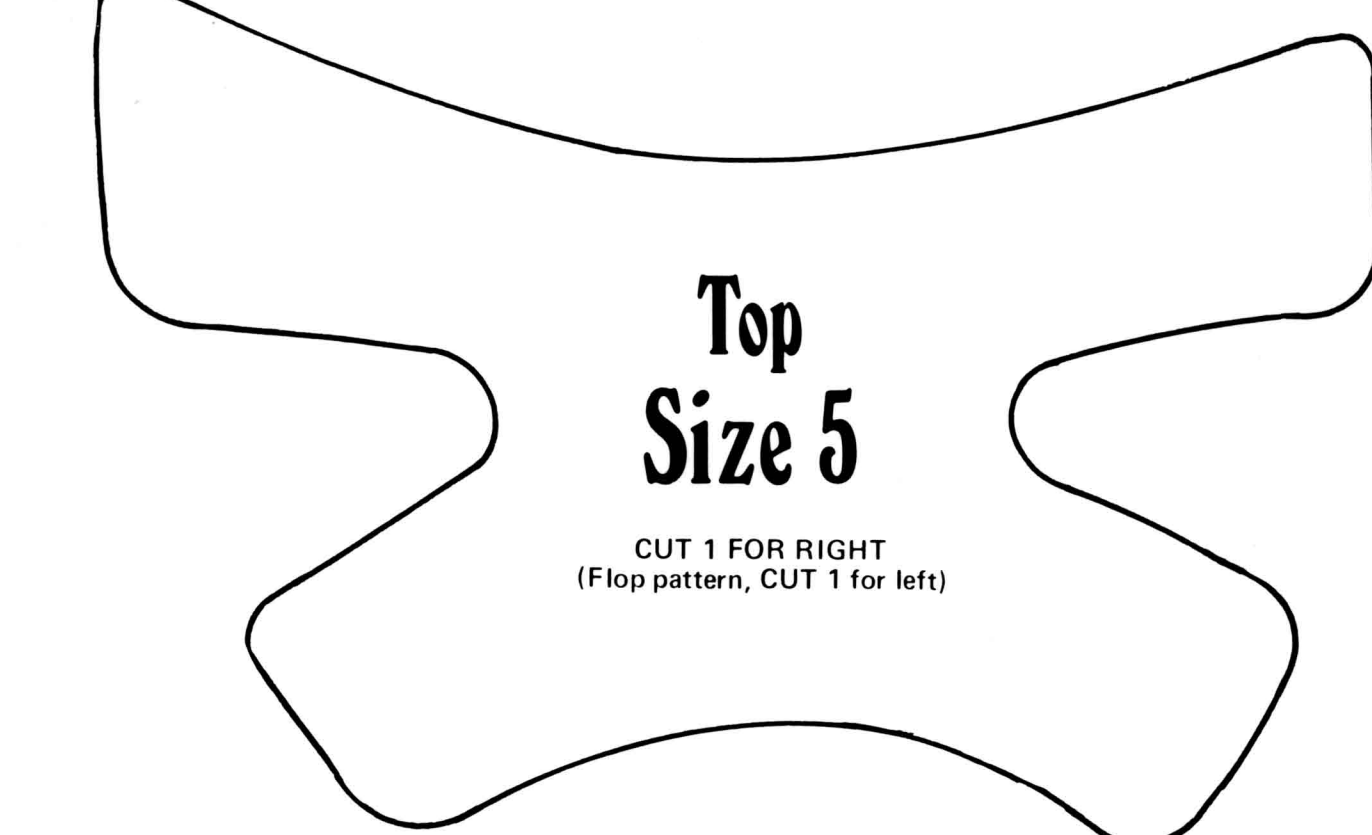
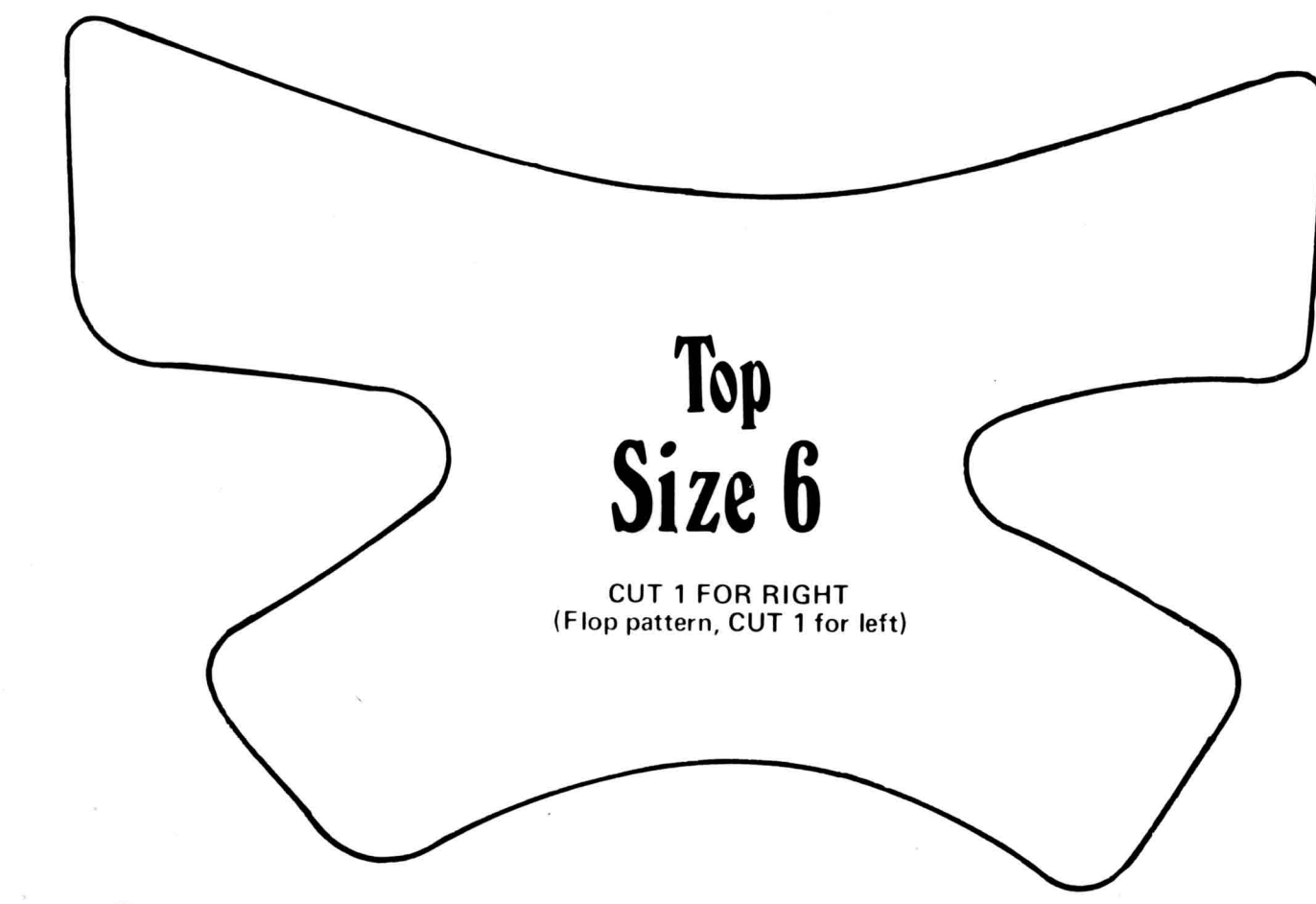
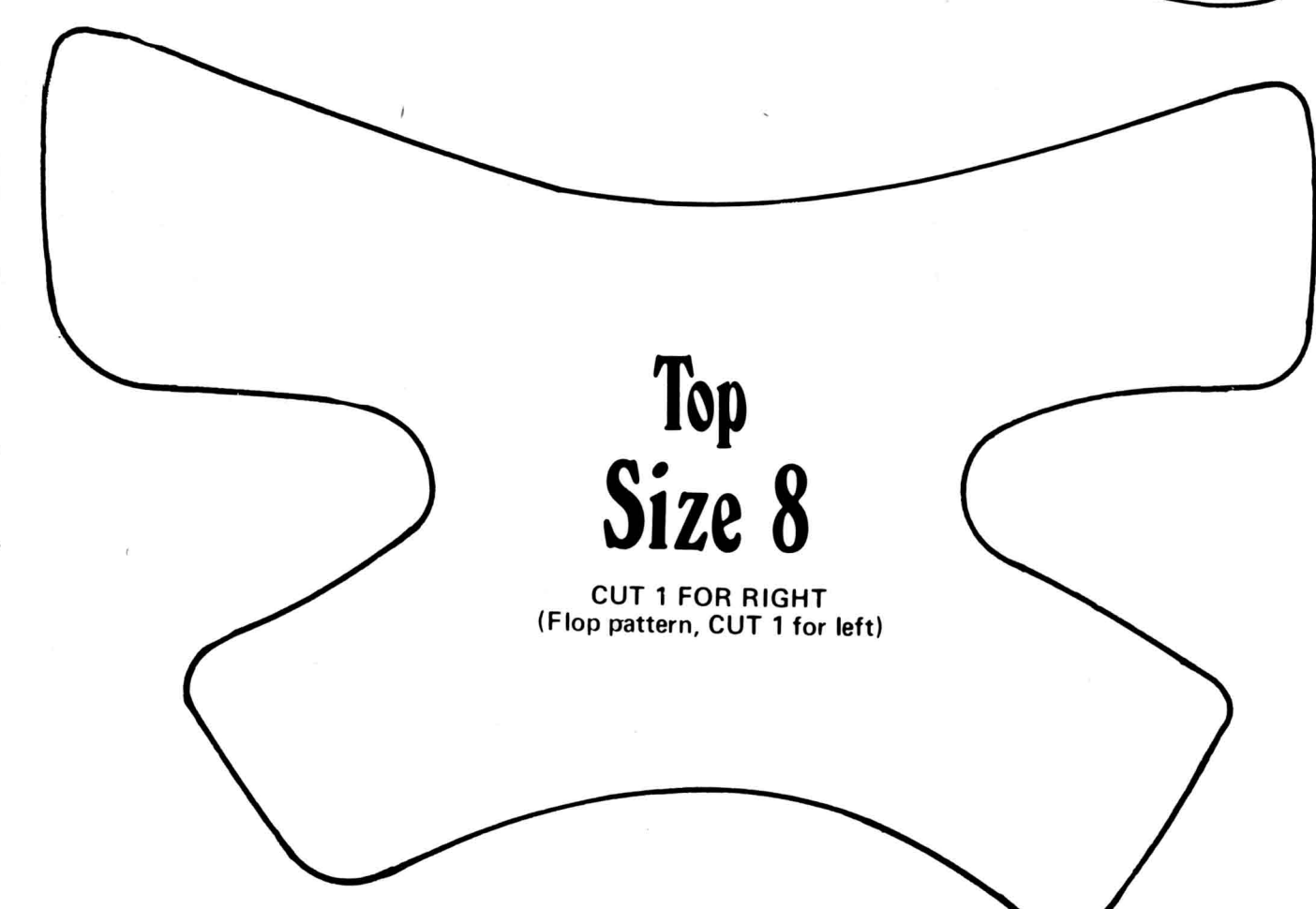

**Buckle Strap  
Sizes 5-10**

# Wedge Sandal Style B



Distributed by Tandy Warehouse Co.,  
A Division of Tandy Leather Co.,  
Fort Worth, Texas

**KIT CONTAINS:**  
Nature-Tand Leather  
Tacks  
Buckles  
Medium Rapid Rivets  
Cutting and Pattern Sheet  
Assembly Instructions

**YOU WILL NEED:**  
Craftsman Cement  
Crafttools  
Knife  
Hammer  
Omega Dye  
Varnish  
8100 Rivet Setter (option:  
#3 Drive Punch

---

## Assembly Instructions



# Pattern Parts

NOTE: Cut sole pieces from smaller piece of leather and cut all other pieces from largest piece of leather.

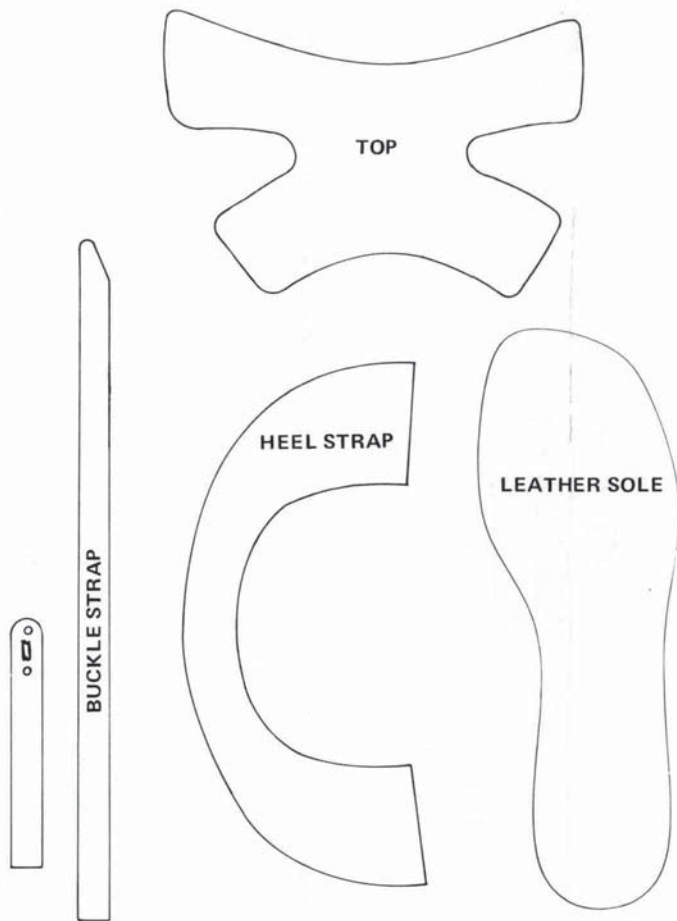

## Sizes

## Heel Str



**5-10**

CUT 1 FOR RIGHT SANDAL  
(Flop pattern, CUT 1 for left sandal)

**Leather Sole**  
**Size 5**

**Leather Sole**  
**Size 6**

rap



CUT 1 FOR RIGHT SANDAL  
(Flop pattern, CUT 1 for left sandal)

**Leather Sole**  
**Size 7**

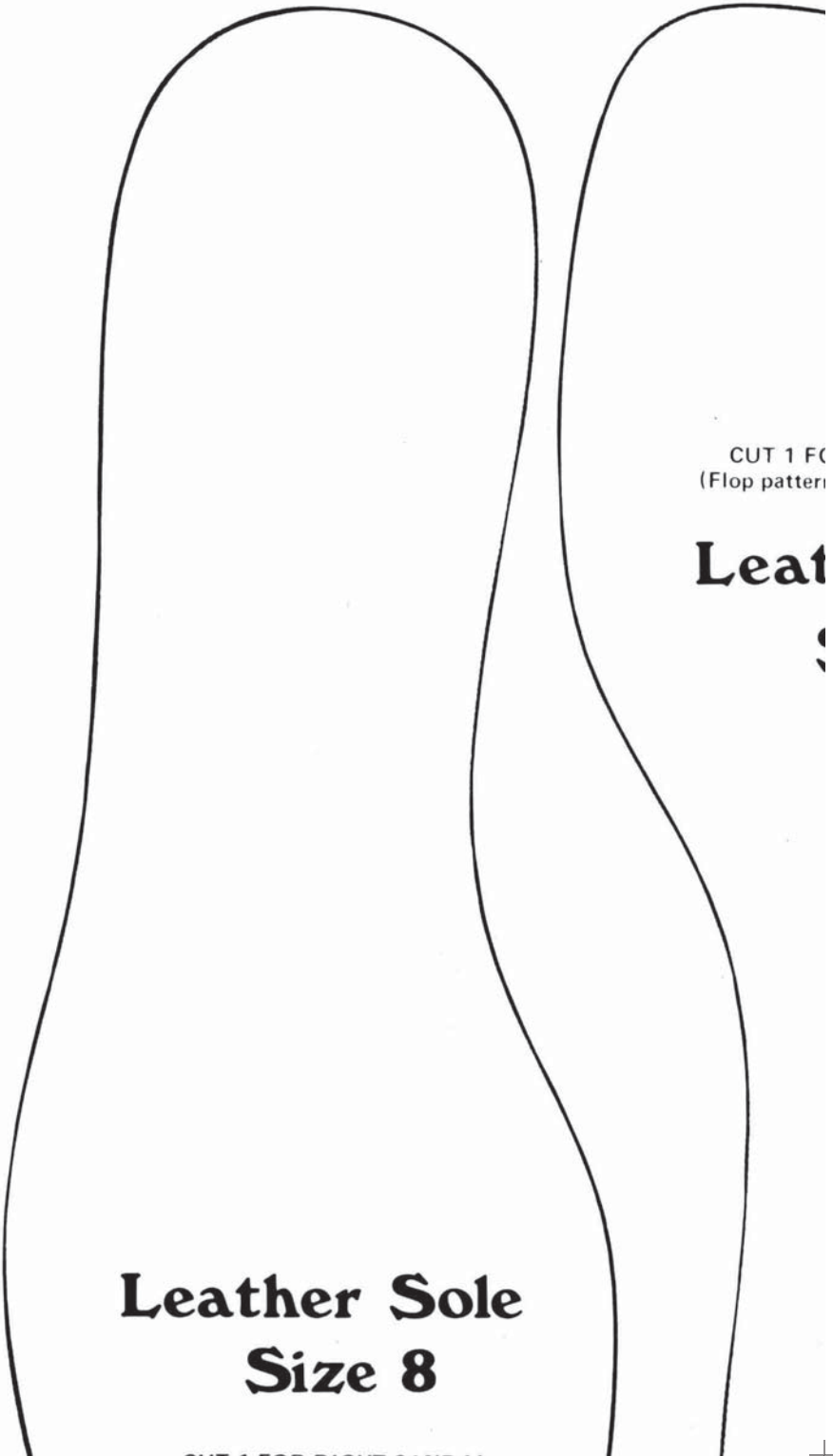

CUT 1 FOR RIGHT SANDAL  
(Flop pattern, CUT 1 for left sandal)

**Leather Sole**

**Leather Sole**  
**Size 8**

DR RIGHT SANDAL  
(CUT 1 for left sandal)

**Leather Sole**  
**Size 9**

**Leather Sole**  
**Size 10**



**NOTE:** Read through all assembly instructions before beginning.

**SIZING:** After paper pattern parts have been cut out, hold them to your foot, in the proper position, to insure each pattern is large enough before cutting it out of the leather. This is especially important for the top piece, which must come down far enough on the wooden sole to be secured with tacks. If you find your first size selection is too short; use the next largest size and trim the leather as needed.

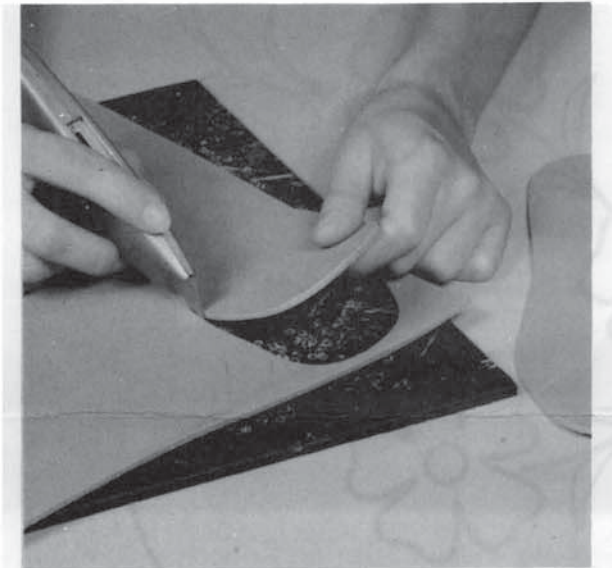

**TRACING TIP:** Tracing the pattern on the leather will be easier if you make a set of cardboard patterns.

**STEP 2:** Cut along the traced lines with a sharp knife.



CUT 1 FOR RIGHT  
(Flop pattern, CUT 1 for

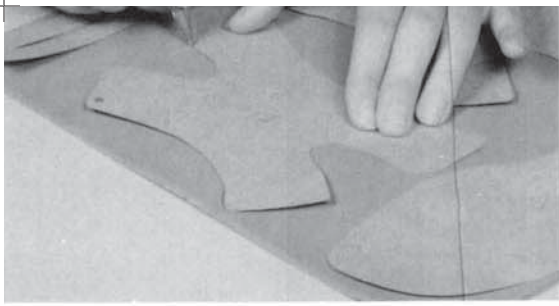

**STEP 1:** Select the correct size patterns (size indicated on wooden soles) to cut leather sole parts. Cut out the paper sole top and remaining parts with shears. Arrange all the pattern parts on grain side of leather and trace around them. (See photo.) To make both sole pieces, flop sole pattern and retrace.

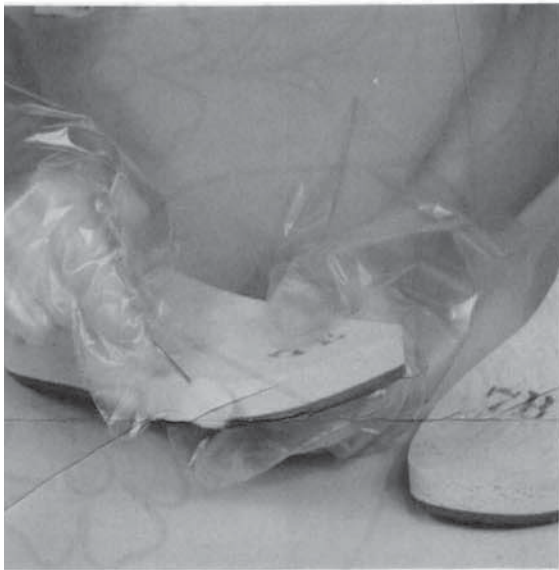

**STEP 3:** Stain and varnish or just varnish the wooden soles.

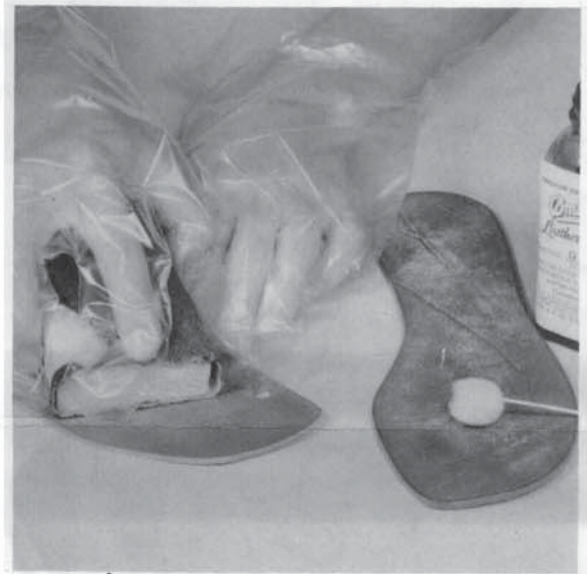

**NOTE:** Do all carving and stamping before dyeing. (See photo-carve patterns on back of sheet.)

**STEP 4:** Using Nature-Tand dyeing technique on back of this sheet, dye the leather parts and then apply Carnauba Cream. Let dry and buff to a shine.

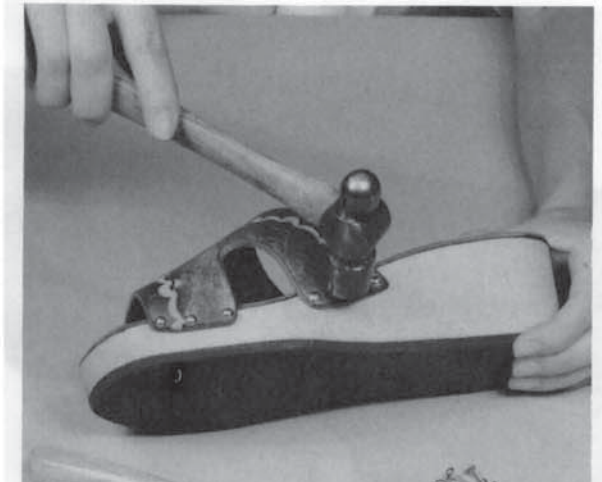

T  
or left)

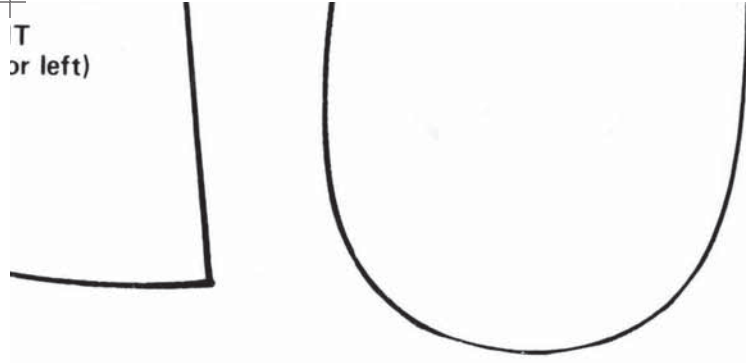

CUT 1 FOR RIGHT SANDAL  
(Flop pattern, CUT 1 for left sandal)

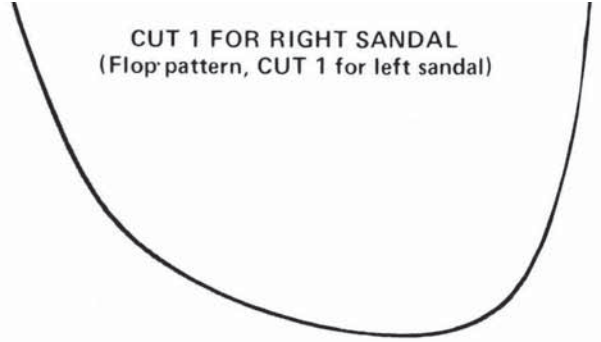

**STEP 5:** Apply Craftsman Cement to the top of the wooden soles and to flesh side of the leather soles. Allow to dry until it becomes tacky.

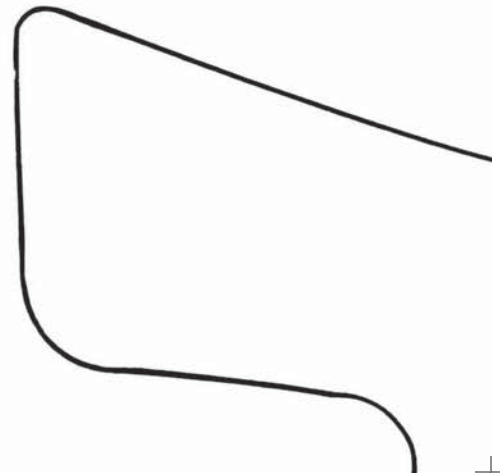
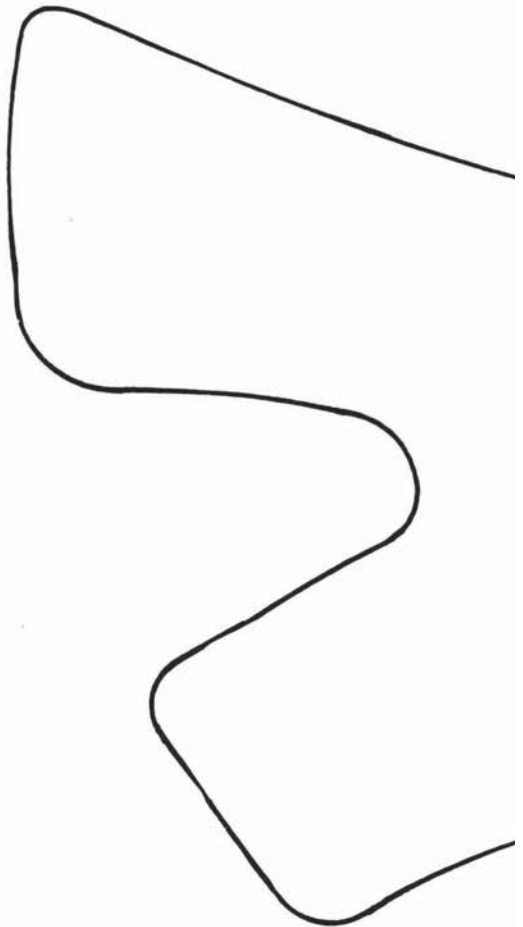
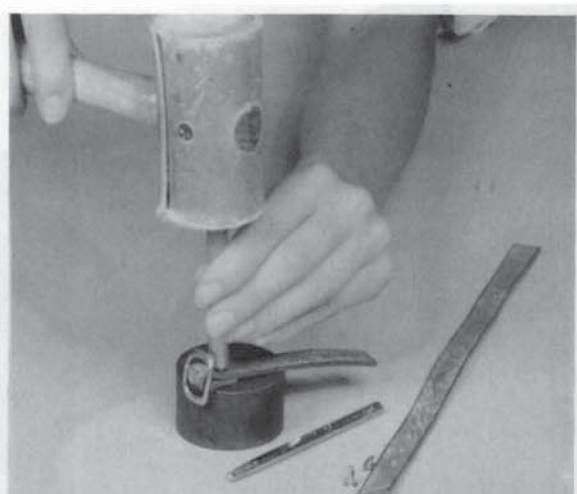

CUT 1 FOR RIGHT SANDAL  
(Flop pattern, CUT 1 for left sandal)

**Top  
Size 7**

CUT 1 FOR RIGHT  
(Flop pattern, CUT 1 for left)

**Top**  
a' e





CUT 1 FOR RIGHT SANDAL  
(Flop pattern, CUT 1 for left sandal)

**Top**  
**Size 8**

CUT 1 FOR RIGHT  
(Flop pattern, CUT 1 for left)

**Top**

**STEP 6:** Aligning edges; carefully press the toe of the leather sole to the toe of the wooden sole, with edges aligned at toe, work toward the heel. Press leather sole firmly in place. If leather extends off edge of wooden sole, trim with a sharp knife and carefully dye edges again. (Use small brush.)

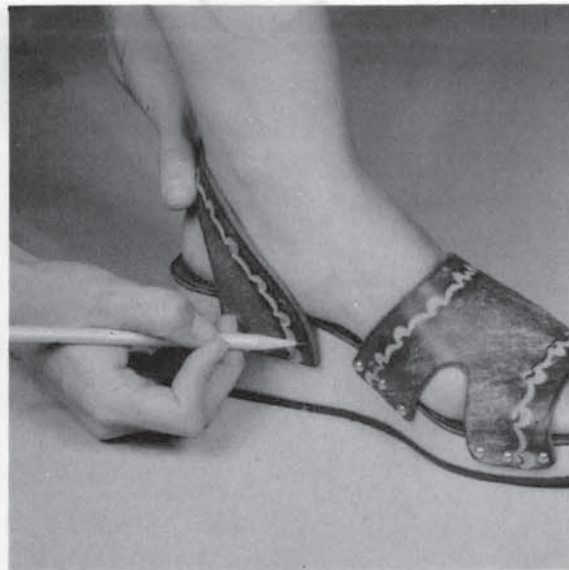

**STEP 10:** Place heel strap around heel in a comfortable position. With a pencil, mark where the strap should be trimmed. Leather should come down on wooden sole far enough for nails to catch both. Trim and dye edges.

## Rapid Rivet Instructions

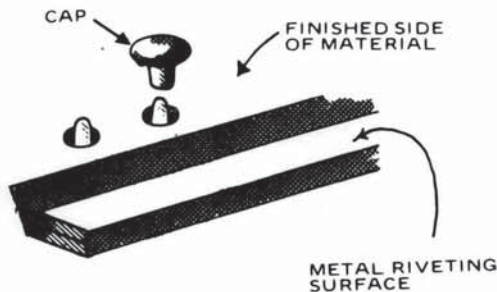

For best results use a rivet setter rivet slightly longer than thickness in leather (use drive or rotary put rivet. Place rivet post through leather smooth, dense surface. Place rivet on cap end of rivet setter on cap (so edges of setter will not mark rivet with rawhide mallet once or twice. set tightly in leather and does not



**STEP 7:** Place your foot on the sole and position leather top across top of foot, as shown. Mark wooden sole, lightly, with pencil around edges of leather top for placement.



**STEP 8:** Nail leather top to wooden sole, as shown, using three tacks on each strip.

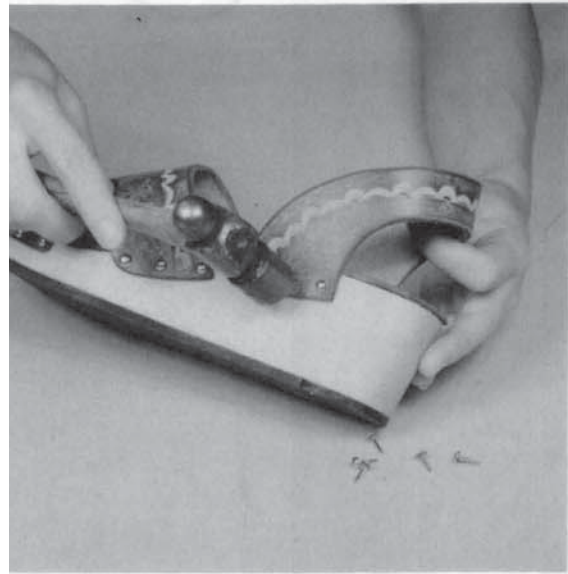

**STEP 11:** Place foot in sandal and pull heel strap until comfortable. Now position ends of heel strap on wooden sole, mark on wooden sole and nail in place.



**STEP 12:** Attach top strap to buckle strap through second hole to make one unit. Place unit over foot as shown. Mark and cut off excess leather, dye edges.

and rawhide mallet. Use  
is of leathers. Punch hole  
nch) slightly larger than  
athers and place on hard,  
t cap on post. Place cone  
e certain rivet is centered  
ivet cap) and tap sharply  
. Check to see that rivet is  
turn.

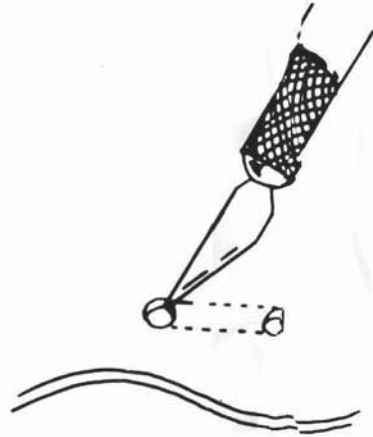

To make slots in leather, use a 3/4" oblong punch or no. 3 punch. If no. 3 punch is used, mark slots on leather using pattern. Punch no. 3 hole at each end of mark, then cut from hole to hole (along dotted lines) as illustrated.



**STEP 9:** Punch holes in end of straps as indicated on pattern. Insert buckle tongue through slit from grain side of buckle strap, fold buckle strap around buckle (grain side to grain side) and align rivet holes. Set rapid rivets using rapid rivet instructions on back of this sheet.



**STEP 13:** Punch holes in ends of buckle strap and in background then rivet back strap to buckle strap (see rapid rivet instructions on back of sheet) on both sides.

## “Nature” Designs

“Nature designs” may be stamped on your leather projects, with the use of leather stamps many different designs can be created by using your own perception of objects around you in “nature”.

As you develop an awareness of “nature designs” and begin transferring them from your mind to the leather surface with leather tools, you will enjoy a most gratifying experience. From the simple smooth lined to the most intricate of details, you can express your own impressions of visual and emotional experiences.

You may wish to simply dye and finish your project. Either way, you can “go back to nature” making your own custom leather items.

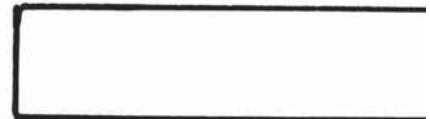
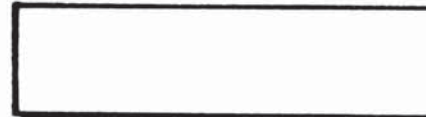
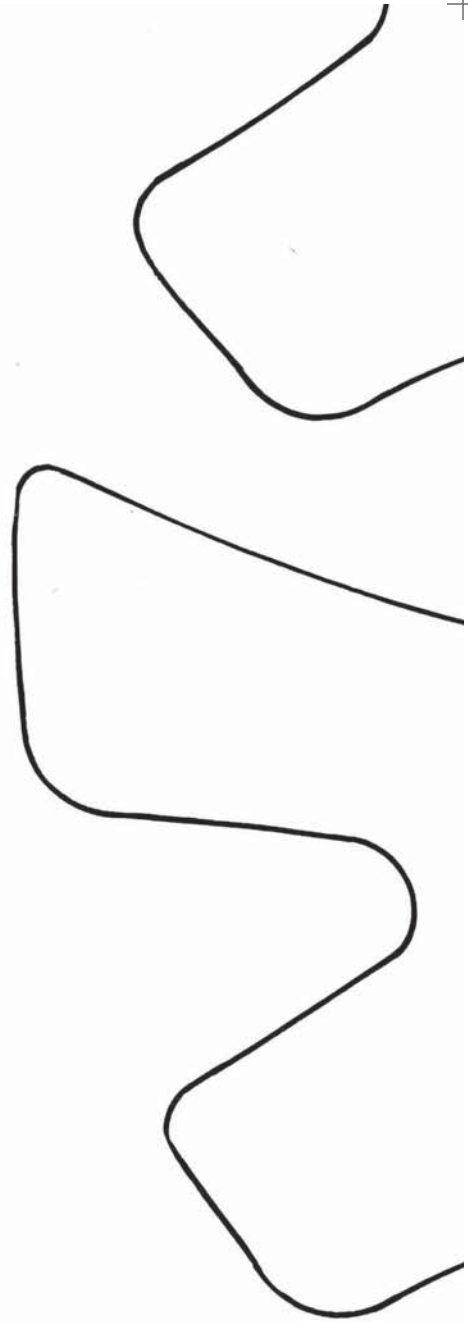

# Size 6

CUT 1 FOR RIGHT  
(Flop pattern, CUT 1 for left)

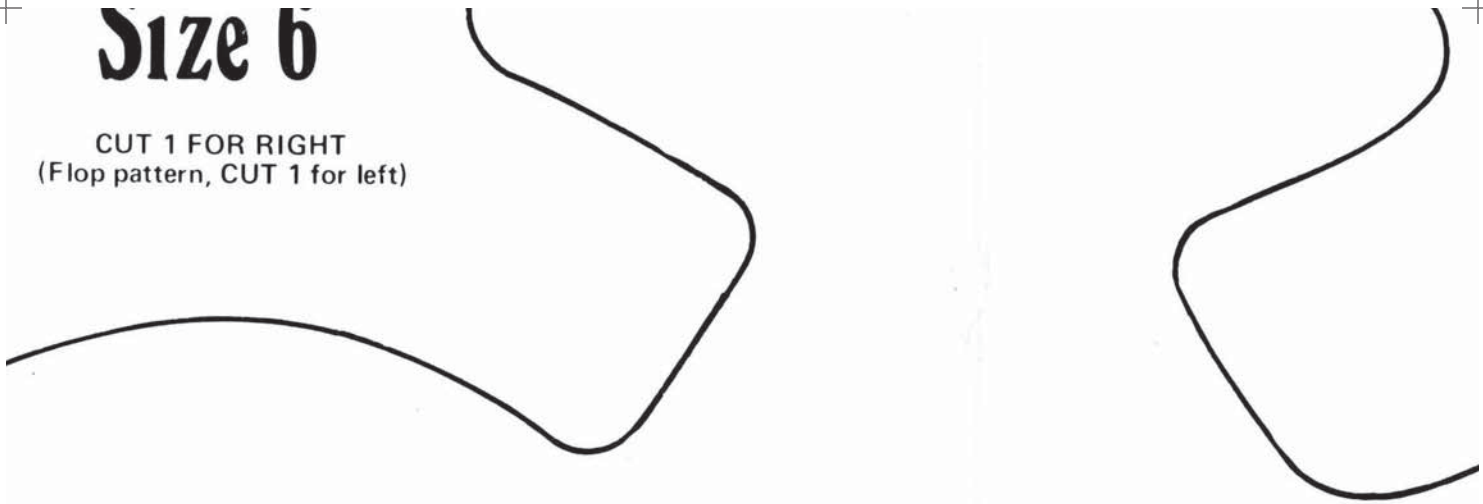

# Top Size 5

CUT 1 FOR RIGHT  
(Flop pattern, CUT 1 for left)

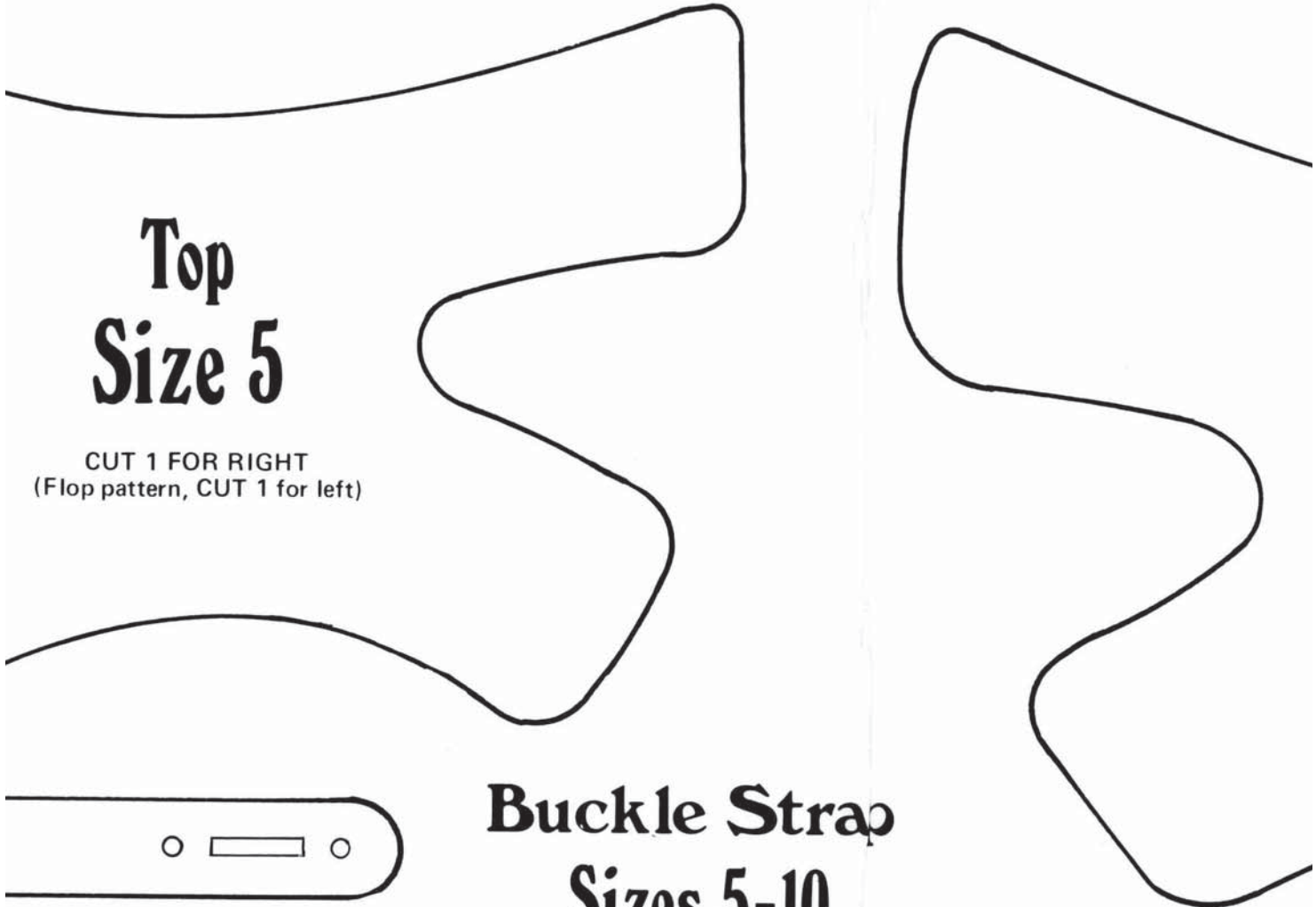

## Buckle Strap Sizes 5-10

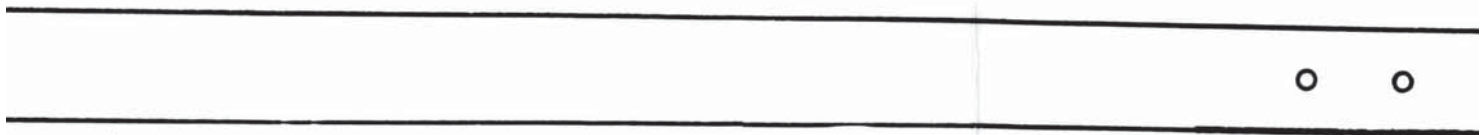

# Size 9

CUT 1 FOR RIGHT  
(Flop pattern, CUT 1 for left)

# Top Size 10

CUT 1 FOR RIGHT  
(Flop pattern, CUT 1 for left)



© Copyright 2010 by Tandy Leather Factory  
All Rights Reserved

## Photo Carves

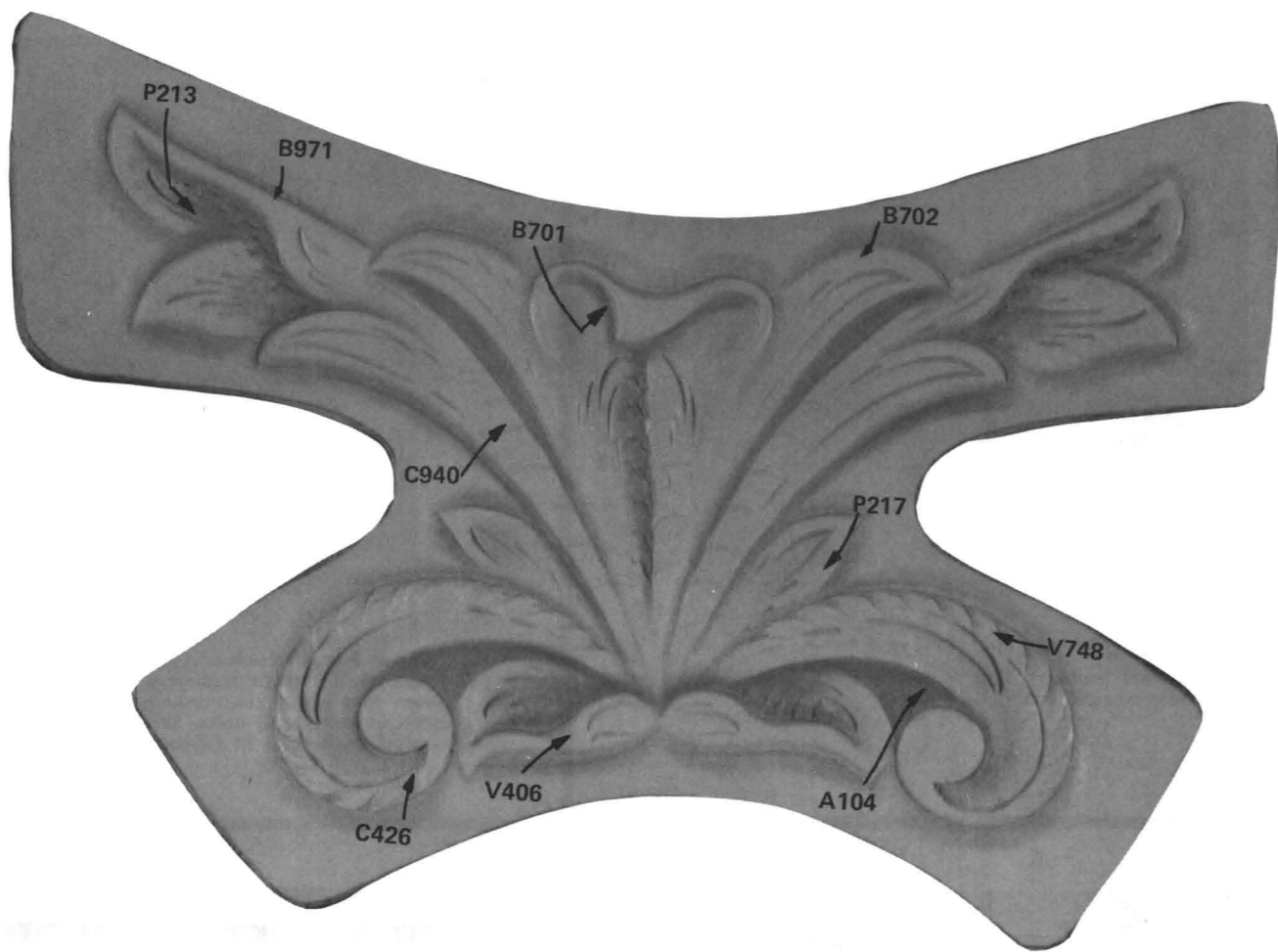
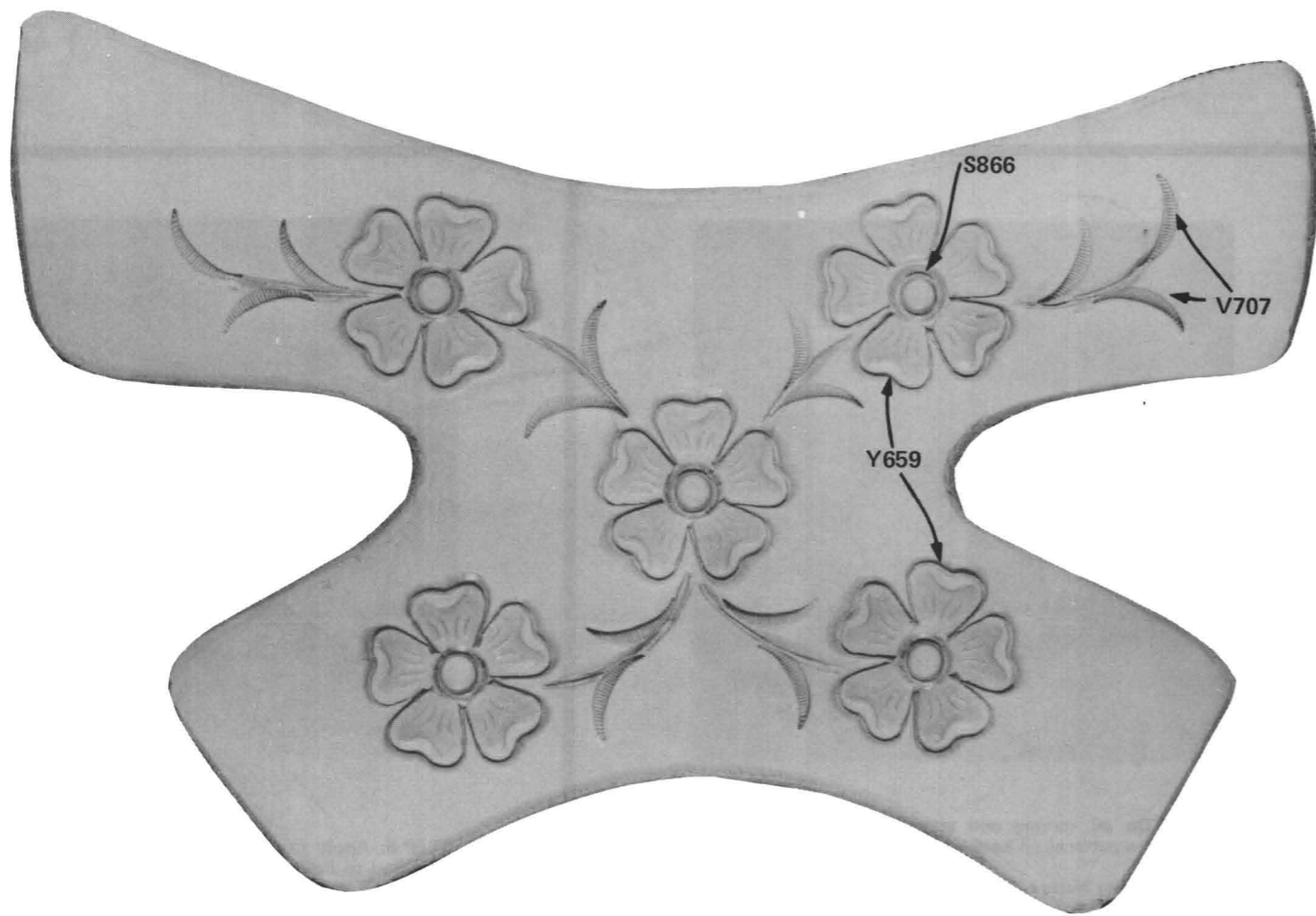
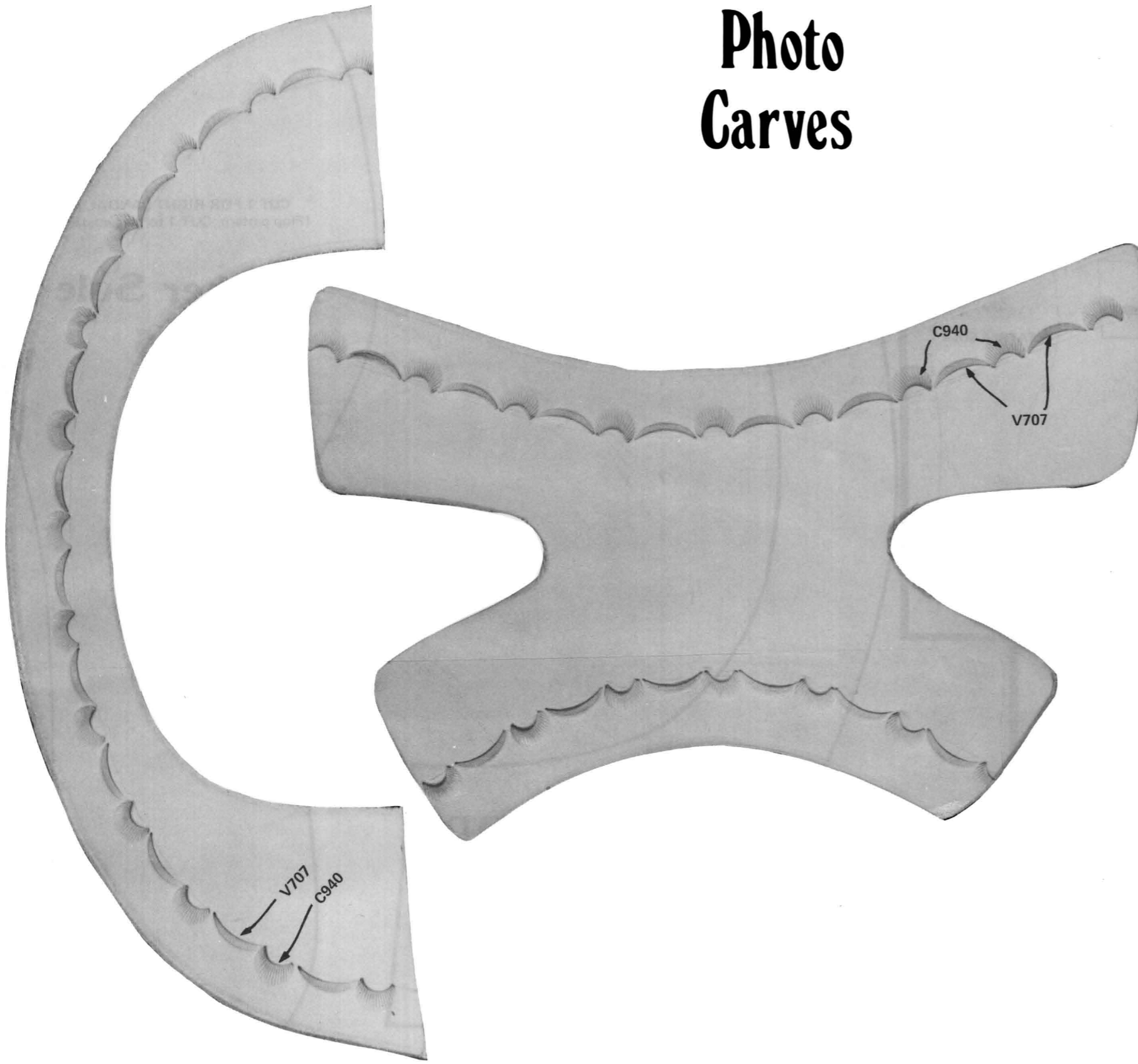

## Nature-Tand Dyeing Instructions

The Nature-Tand dyeing technique allows you to apply dye to the surface of the leather to contrast with the stamped and natural impressions in the leather. With this technique the dye will not enter the stamped impressions. The dyes used are spirit solvent such as Omega Dye.

**Step 1.** Wrap a length of cloth around a sponge or wooden block several times. Apply dye to the cloth and blot on a paper towel until cloth has enough dye remaining to color only the surface of the leather. If too much dye remains it may run into the impressions. For shading an edge or small area, use a small piece of sponge without a cloth or a wool dauber.

**Step 2.** With the cloth, apply dye to the surface of the leather, rubbing briskly so a burnished effect is achieved. Apply more dye to cloth as needed, blotting before applying to leather. Dye all edges.

For a distinctive edge, dye the edges and a border area along them with dark brown or black.

For a more finished look, the back side of the Nature-Tand leather may be dyed with Omega dye and finished with Carnauba Cream.

The basic colors recommended are; dark brown, medium brown, tan, a combination of red (applied first) and dark brown, light brown or cordovan.

**Step 3.** Your "nature design" can be enhanced by dyeing flowers and leaves with Cova Dye. Use a small brush.

**Step 4.** After dye has been applied wait until leather dries before applying a finish. Omega Carnauba Cream makes an excellent finish for this type leather and dye.

## Tracing Patterns

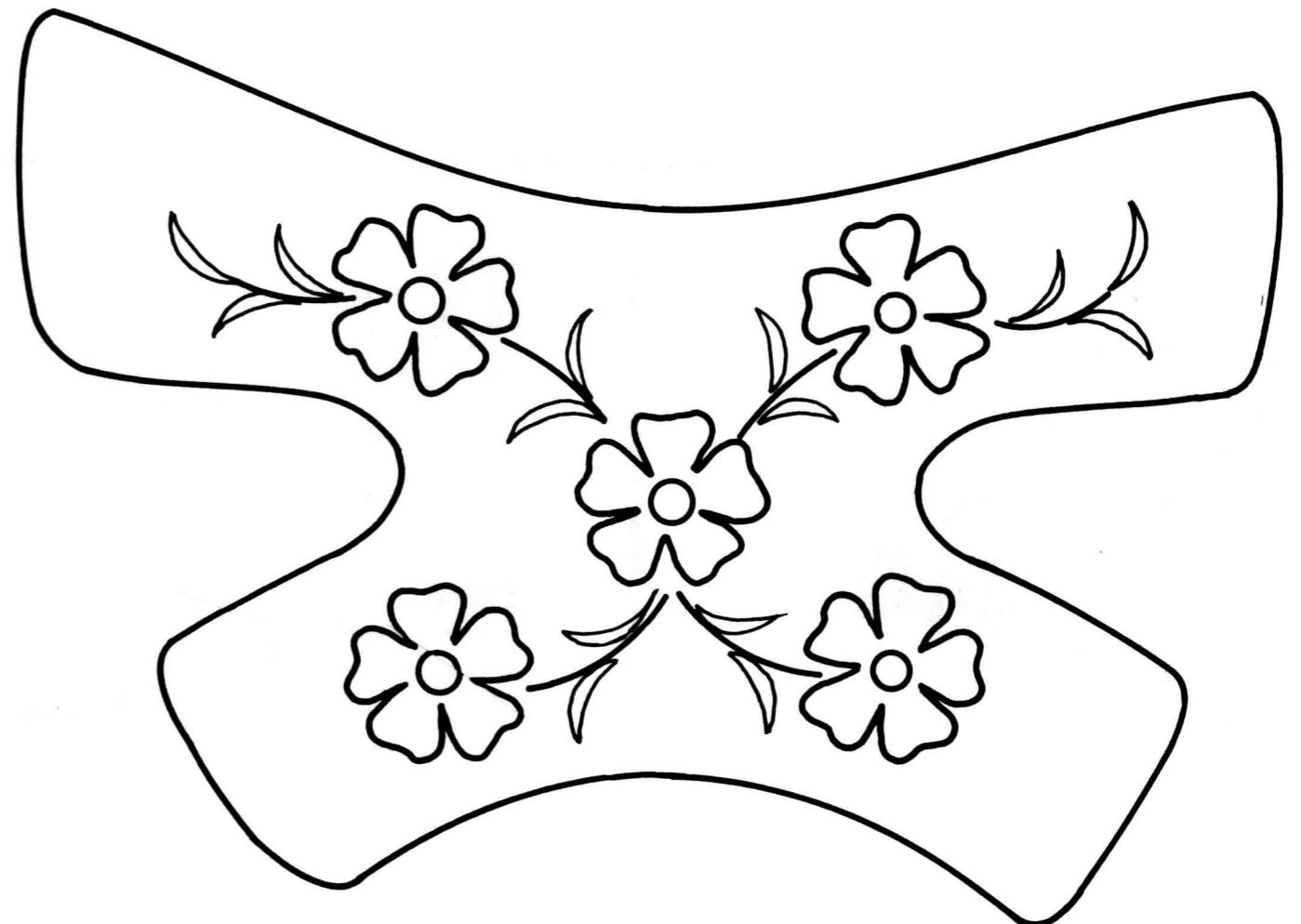

Flop Tracing Pattern for Left Shoe

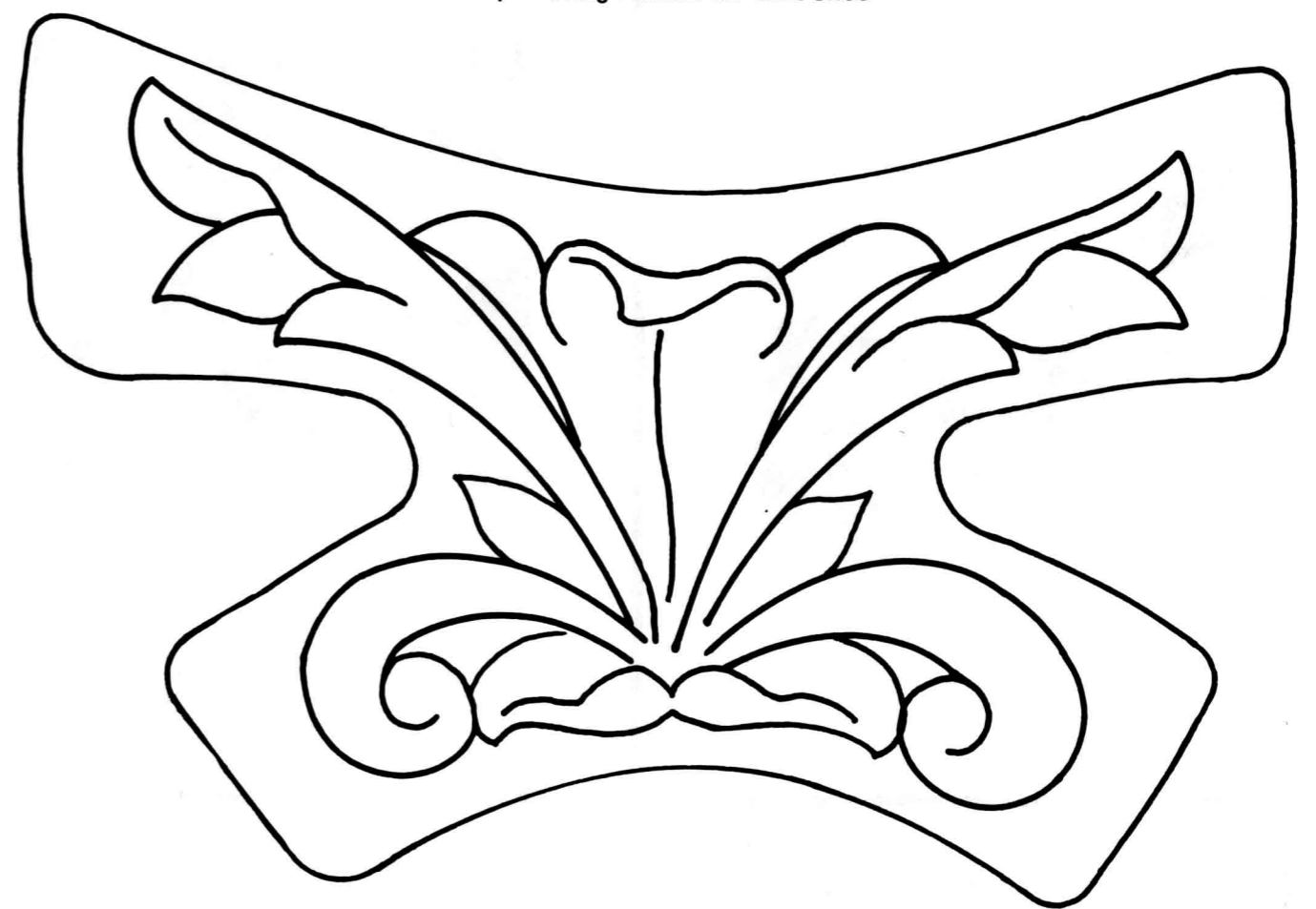

# Photo Carves

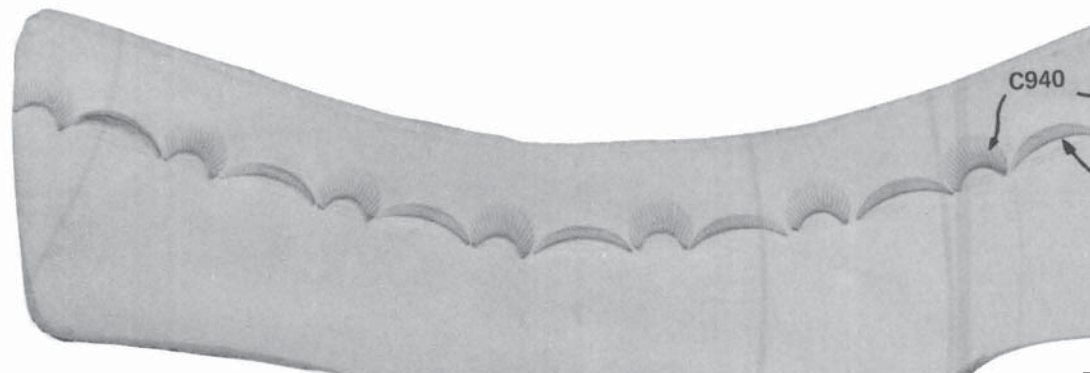



# Nature-Tand Dyeing Instructions

The Nature-Tand dyeing technique allows you to apply dye to the surface of the leather to contrast with the stamped and natural impressions in the leather. With this technique the dye will not enter the stamped impressions. The dyes used are spirit solvent such as Omega Dye.

**Step 1.** Wrap a length of cloth around a sponge or wooden block several times. Apply dye to the cloth and blot on a paper towel until cloth has enough dye remaining to color only the surface of the leather. If too much dye remains it may run into the impressions. For shading an edge or small area, use a small piece of sponge without a cloth or a wool dauber.

**Step 2.** With the cloth, apply dye to the surface of the leather, rubbing briskly so a burnished effect is achieved. Apply more dye to cloth as needed, blotting before applying to leather. Dye all edges.

For a distinctive edge, dye the edges and a border area along them with dark brown or black.

For a more finished look, the back side of the Nature-Tand leather may be dyed with Omega dye and finished with Carnauba Cream.

The basic colors recommended are; dark brown, medium brown, tan, a combination of red (applied first) and dark brown, light brown or cordovan.

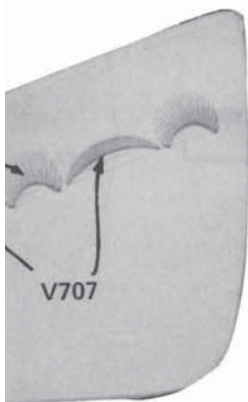

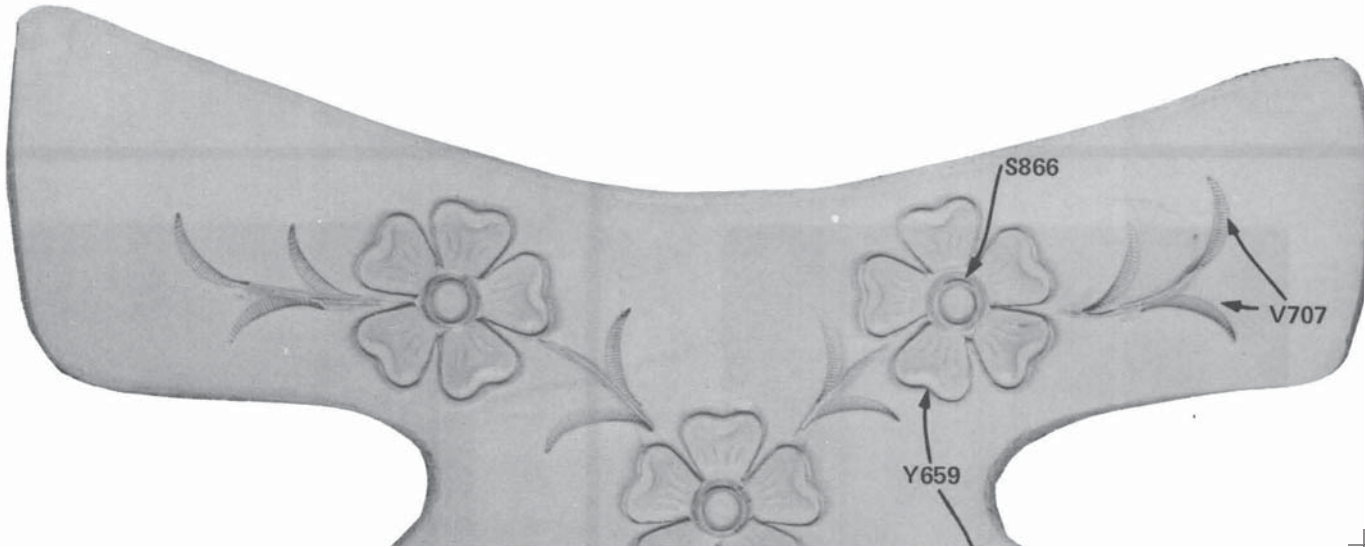
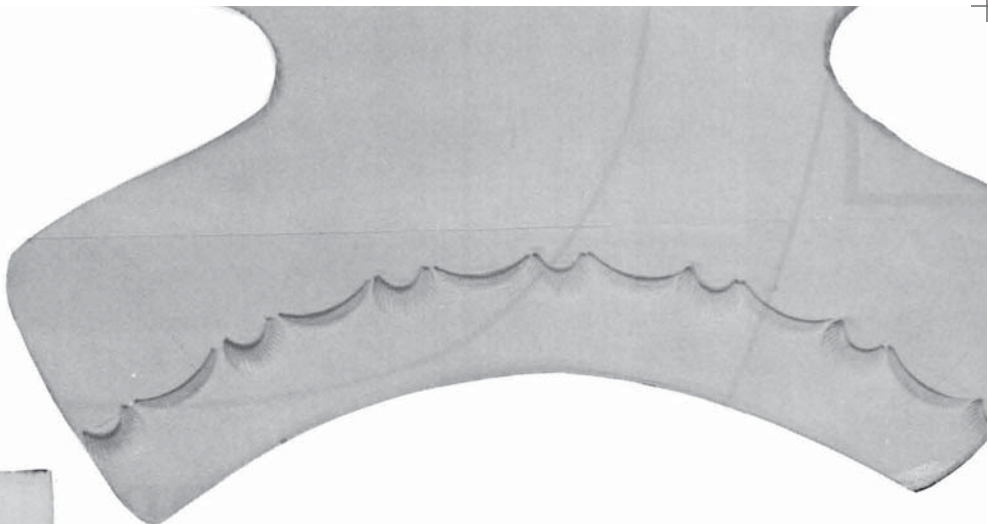
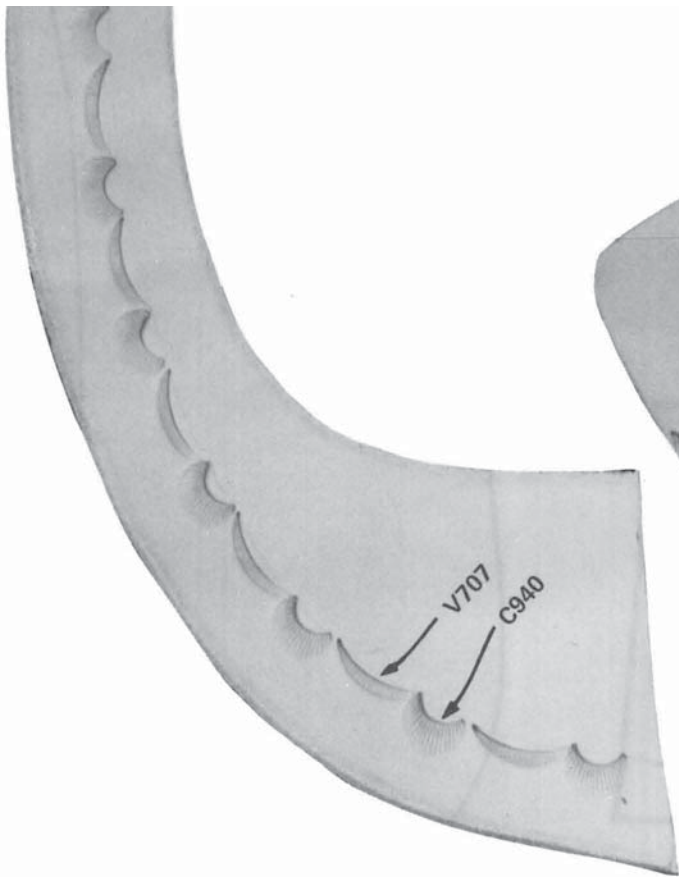

**Step 3.** Your "nature design" can be enhanced by dyeing flowers and leaves with Cova Dye. Use a small brush.

**Step 4.** After dye has been applied wait until leather dries before applying a finish. Omega Carnuba Cream makes an excellent finish for this type leather and dye.

## Tracing Patterns



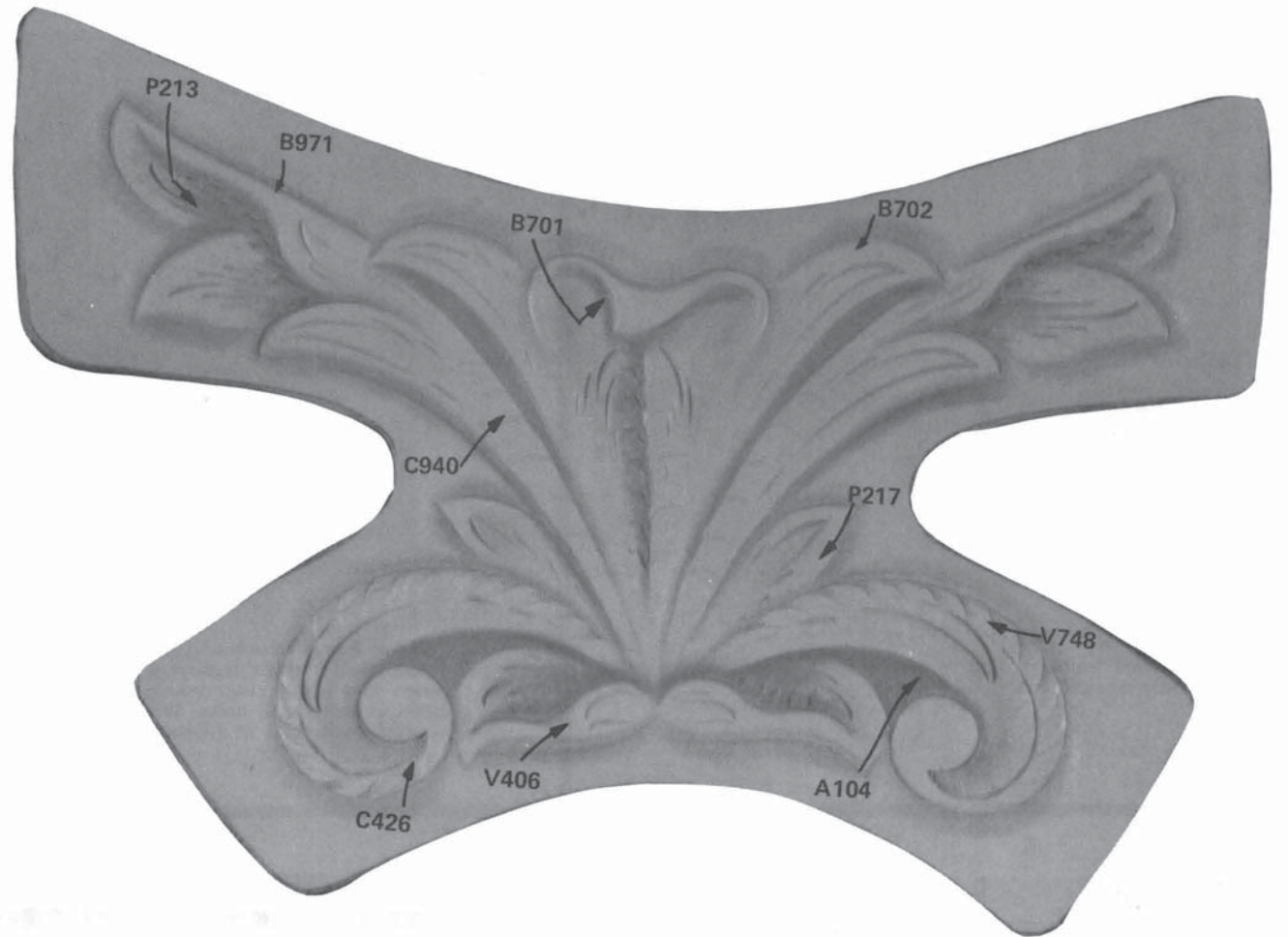



Flop Tracing Pattern for Left Shoe

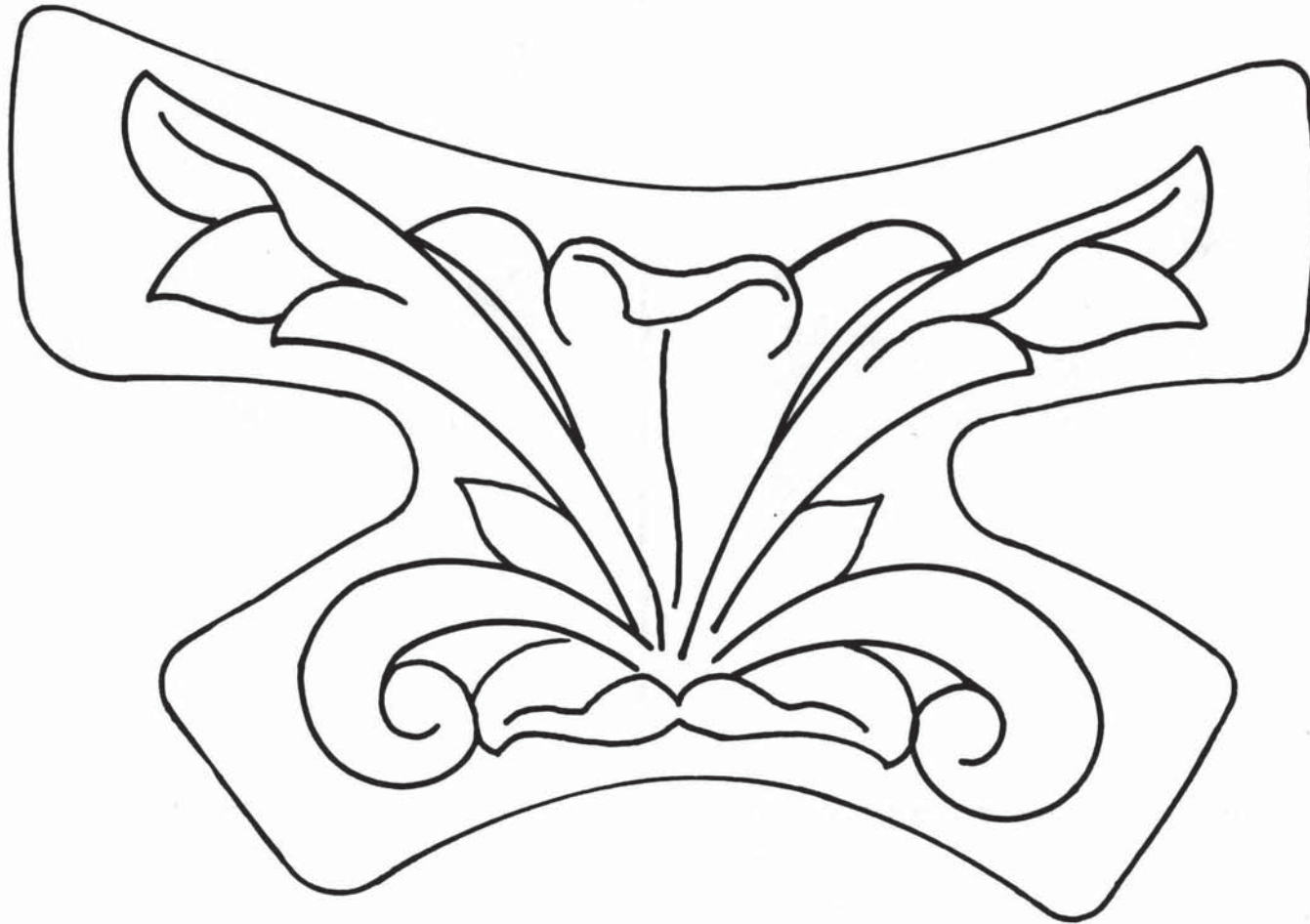



© Copyright 2010 by Tandy Leather Factory  
All Rights Reserved

# Wedge Sandal Style D



Distributed by Tandy Warehouse Co.,  
A Division of Tandy Leather Co.,  
Fort Worth, Texas

**KIT CONTAINS:**  
Nature-Tand Leather  
Tacks  
Buckles  
Medium Rapid Rivets  
Cutting and Pattern Sheets  
Assembly Instructions

**YOU WILL NEED:**  
Craftsman Cement  
Crafttools  
Knives  
Hammer  
Omega Dye  
Varnish  
8100 Rivet Setter (Optional)  
#3 Drive Punch

## Pattern Parts

**NOTE:** Cut sole pieces from smaller piece of leather and cut all other pieces from largest piece of leather.



## Assembly Instructions

**NOTE:** Read through all assembly instructions before beginning.

**SIZING:** After paper parts of pattern have been cut out, hold them to your feet, in the proper positions, to insure each pattern is large enough before cutting it out of the leather. This is especially important for the top piece which must come down far enough on the wooden sole, to be secured with tacks. If you find your first selection is too short; use the next largest size and trim the leather, as needed.

CUT 1 FOR RIGHT SANDAL  
(Flop pattern, CUT 1 for left sandal)

**Leather Sole  
Size 5**

CUT 1 FOR RIGHT SANDAL  
(Flop pattern, CUT 1 for left sandal)

**Leather Sole  
Size 7**

CUT 1 FOR RIGHT SANDAL  
(Flop pattern, CUT 1 for left sandal)

**Leather Sole  
Size 9**

**Leather Sole  
Size 6**

CUT 1 FOR RIGHT SANDAL  
(Flop pattern, CUT 1 for left sandal)

**Leather Sole  
Size 8**

CUT 1 FOR RIGHT SANDAL  
(Flop pattern, CUT 1 for left sandal)

**Leather Sole  
Size 10**

CUT 1 FOR RIGHT SANDAL  
(Flop pattern, CUT 1 for left sandal)

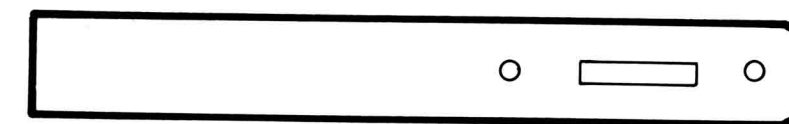

**Buckle Strap**

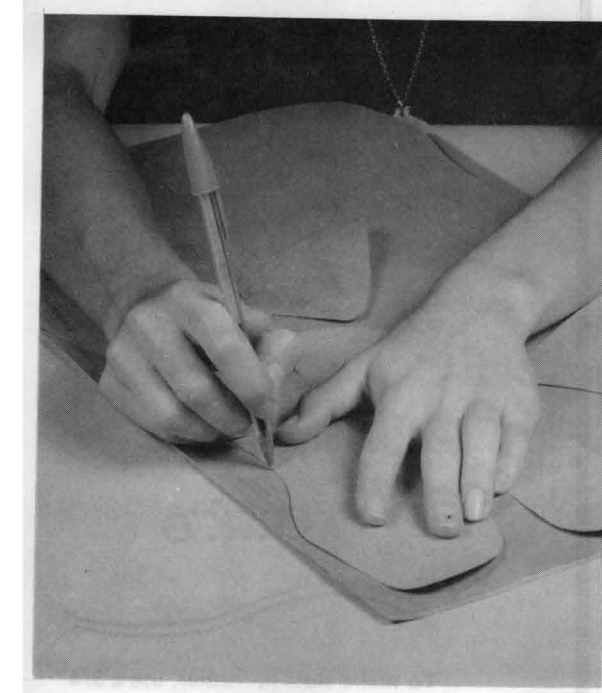

**STEP 1:** Select the correct size patterns (size indicated on wooden soles) to cut leather sole parts. Cut out the paper sole top and remaining parts with shears. Arrange all the pattern parts on grain side of leather and trace around them. (See photo.) To make both sole pieces, flop sole pattern and retrace.



**TRACING TIP:** Tracing the pieces of pattern on the leather will be easier if you make a set of cardboard patterns.  
**STEP 2:** Cut along the traced lines with a sharp knife.

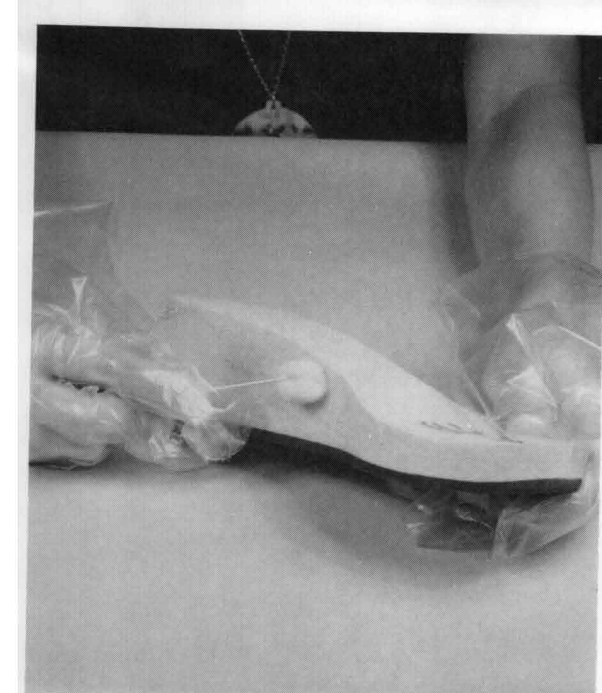

**STEP 3:** Stain and varnish, or just varnish the wooden soles.

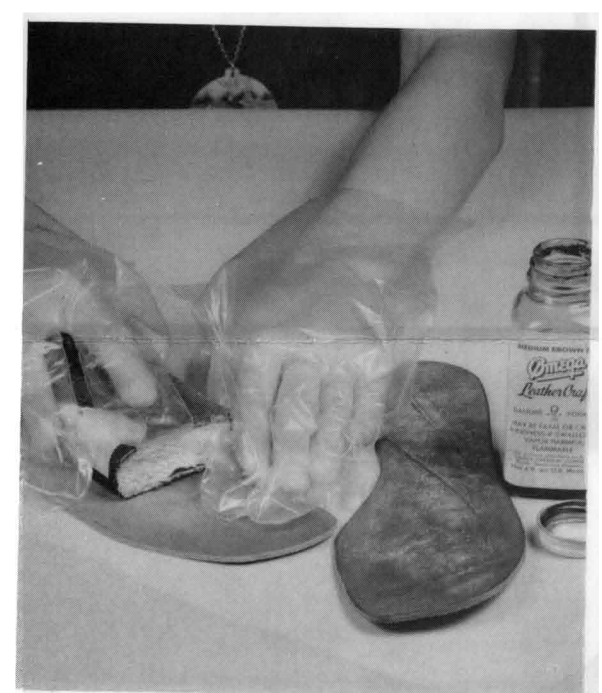

**NOTE:** Do all carving and stamping before dyeing (see photo-carve patterns).  
**STEP 4:** Using Nature-Tand dyeing techniques on back of this sheet, dye the leather parts and then apply Carnauba Cream. Let dry and buff to a shine.



**STEP 5:** Apply Craftsman Cement to the top of the wooden soles and to flesh side of the leather soles. Allow the cement to dry until it becomes tacky.



**STEP 6:** Aligning edges; carefully press the toe of the leather sole to the toe of the wooden sole, with edges aligned at toe. Press leather sole firmly in place. Press leather sole off edge of wooden sole, trim with a sharp knife and carefully dye edge again. (Use small brush.)

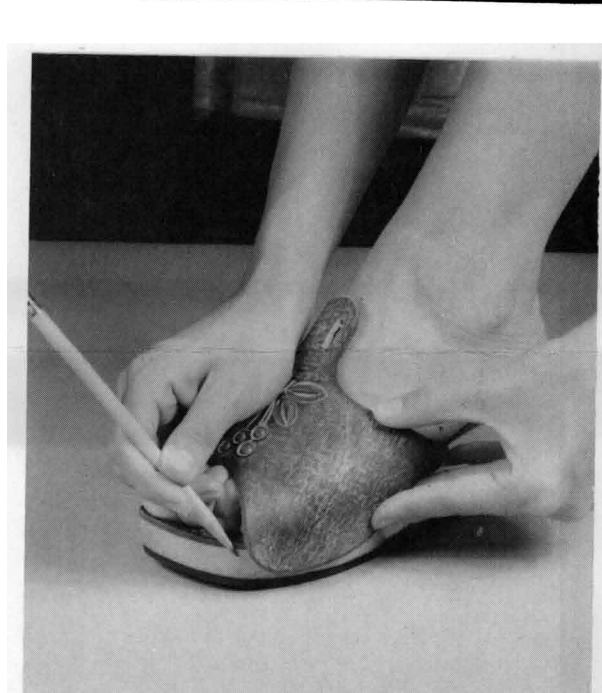

**STEP 7:** Place your foot on the sole and position leather top across top of foot, as shown. Mark wooden sole, lightly, with a pencil around edges of leather top for placement.



**STEP 8:** Nail leather top to wooden sole, as shown. You may wish to start hole in leather with awl, to hold nail while driving it in place. It's easier if you nail the ends first, center the middle tack, and then enter the last two tacks between the end tacks and the center tack.



**STEP 9:** Insert buckle tongue through slit from grain side of buckle strap. Fold buckle strap around buckle (grain side to grain side) and align rivet holes. Set rapid rivets using rapid rivet instructions on reverse side of this sheet.

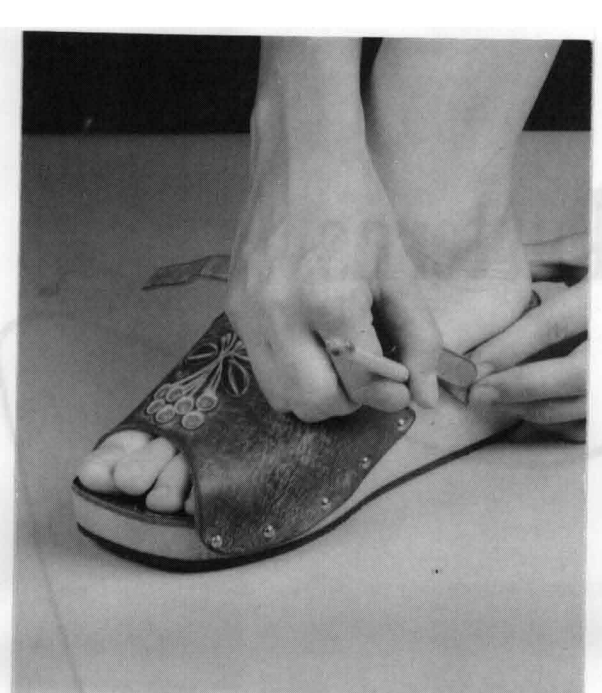

**STEP 10:** Attach top strap to buckle strap with buckle through the second hole to mark one unit. Slip strap and buckle strap through slit in top piece. Position buckle on side of foot. Mark and cut off excess leather, dye edges. Then mark sole lightly, with a pencil as edge, for placement.

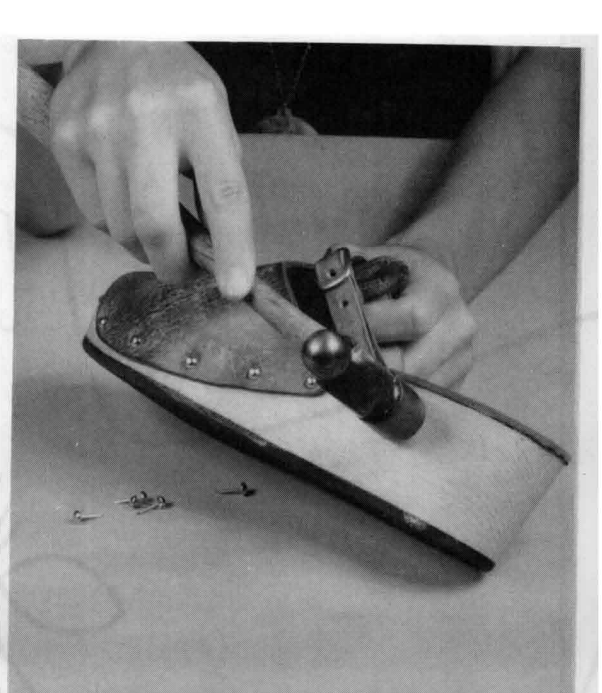

**STEP 11:** Nail strap in place.

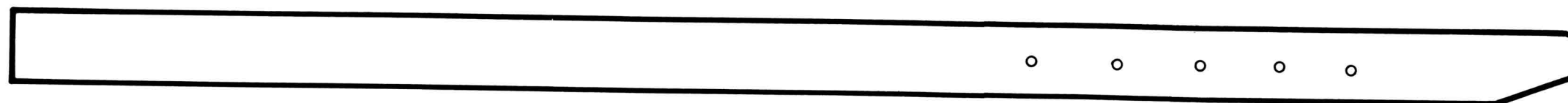

**Top  
Size 5**

CUT 1 FOR RIGHT  
(Flop pattern, CUT 1 for left)



**Top  
Size 6**

CUT 1 FOR RIGHT  
(Flop pattern, CUT 1 for left)

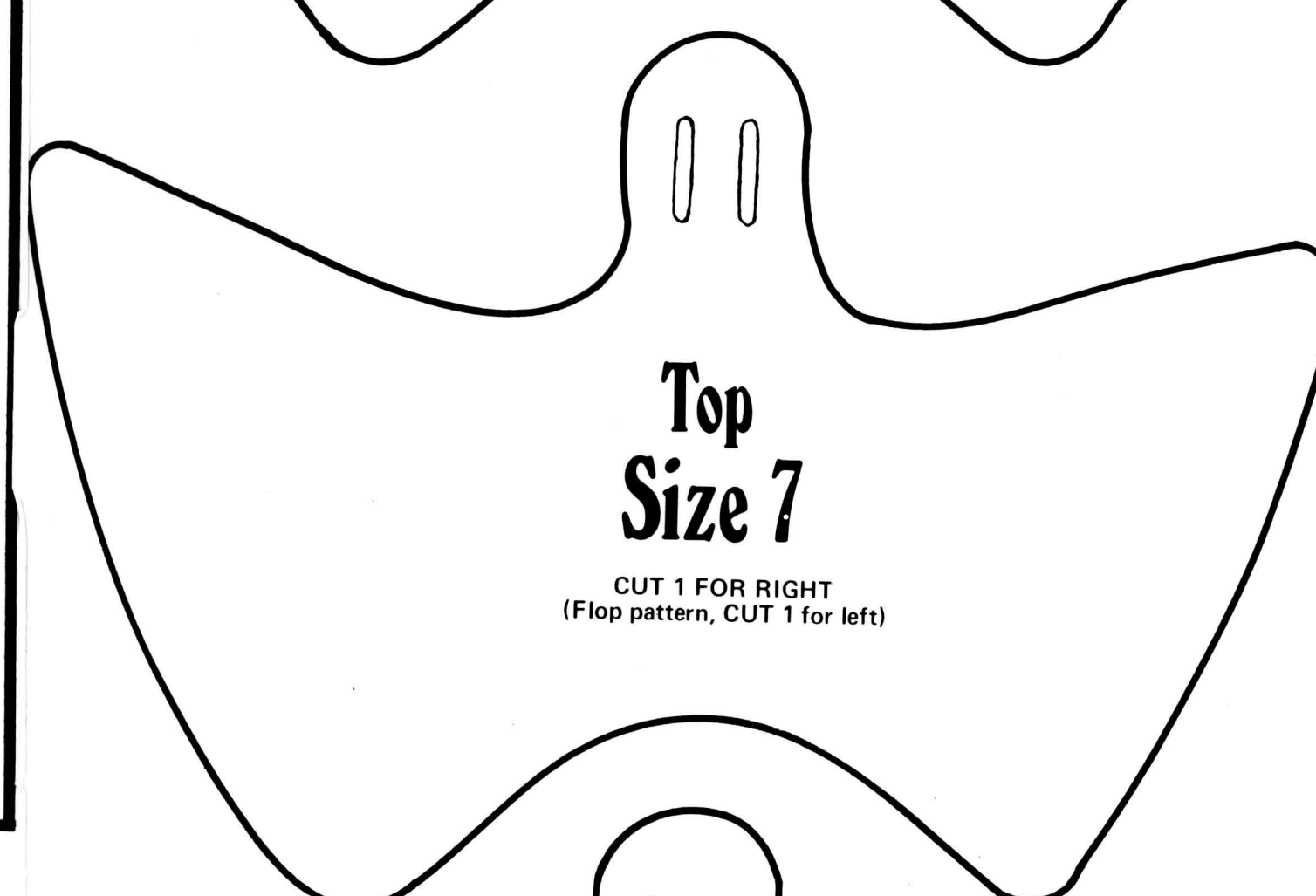

**Top  
Size 7**

CUT 1 FOR RIGHT  
(Flop pattern, CUT 1 for left)

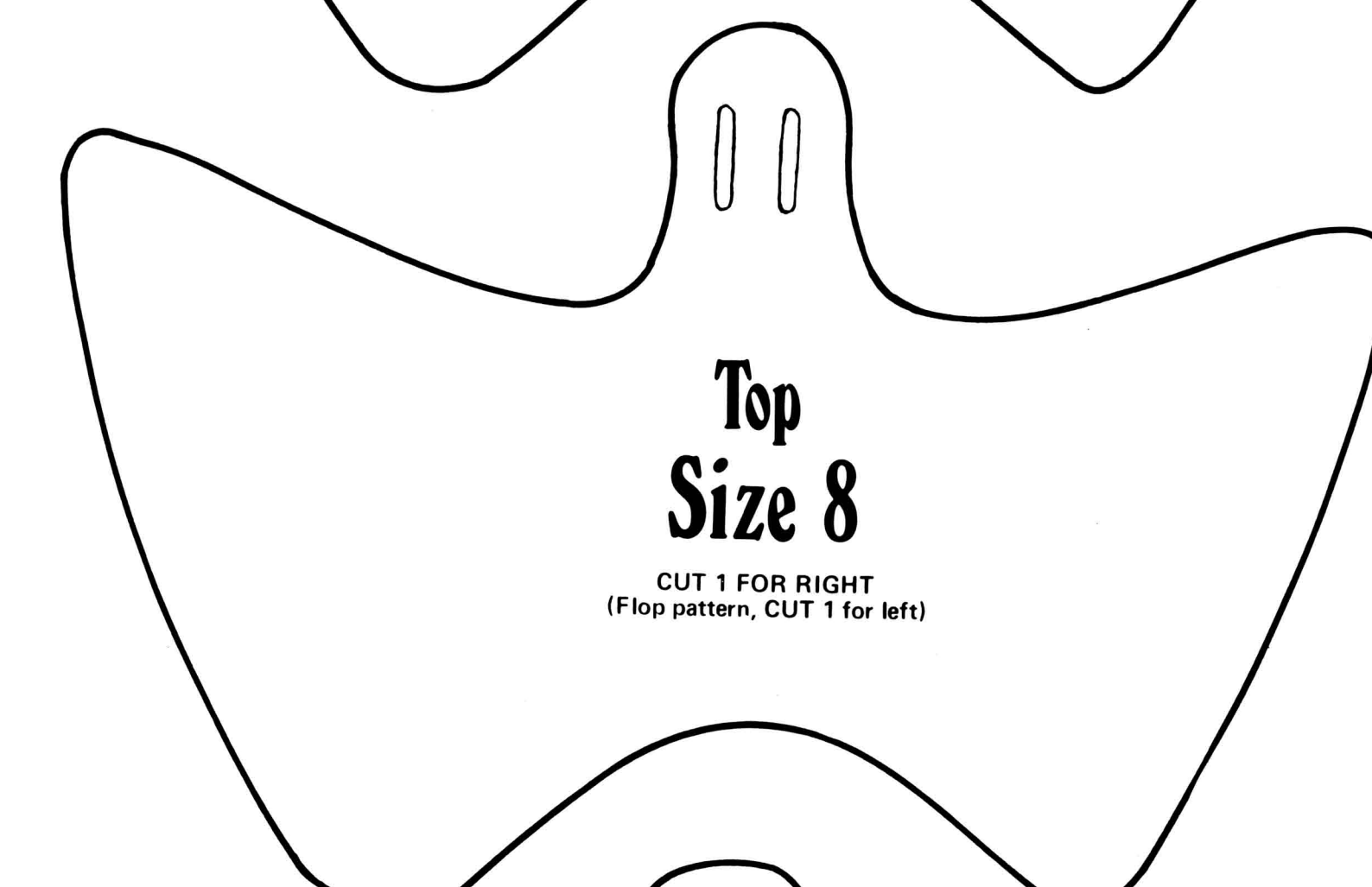

**Top  
Size 8**

CUT 1 FOR RIGHT  
(Flop pattern, CUT 1 for left)

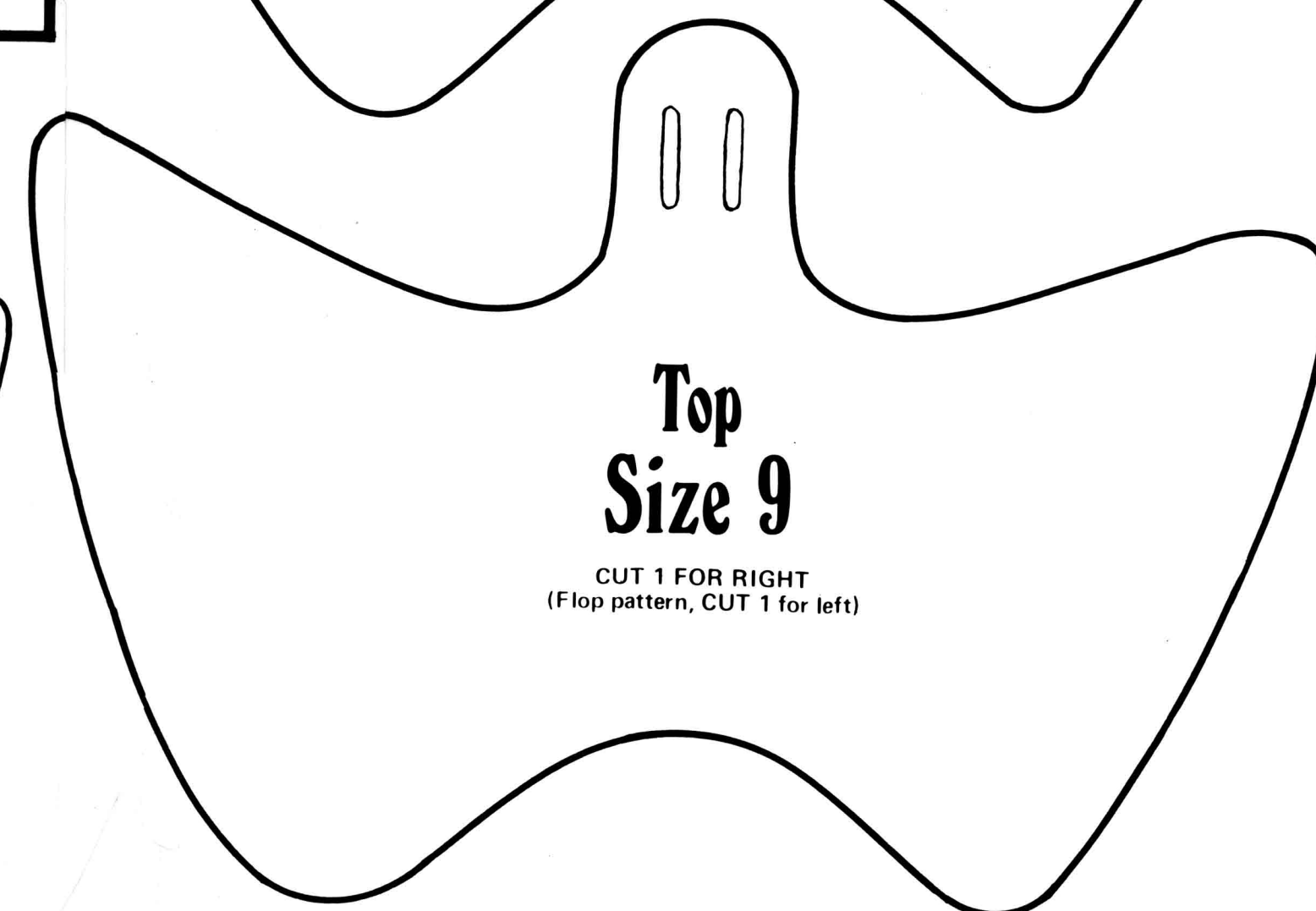

**Top  
Size 9**

CUT 1 FOR RIGHT  
(Flop pattern, CUT 1 for left)



**Top  
Size 10**

CUT 1 FOR RIGHT  
(Flop pattern, CUT 1 for left)

## Tracing Patterns

FLOP PATTERN FOR LEFT SHOE.

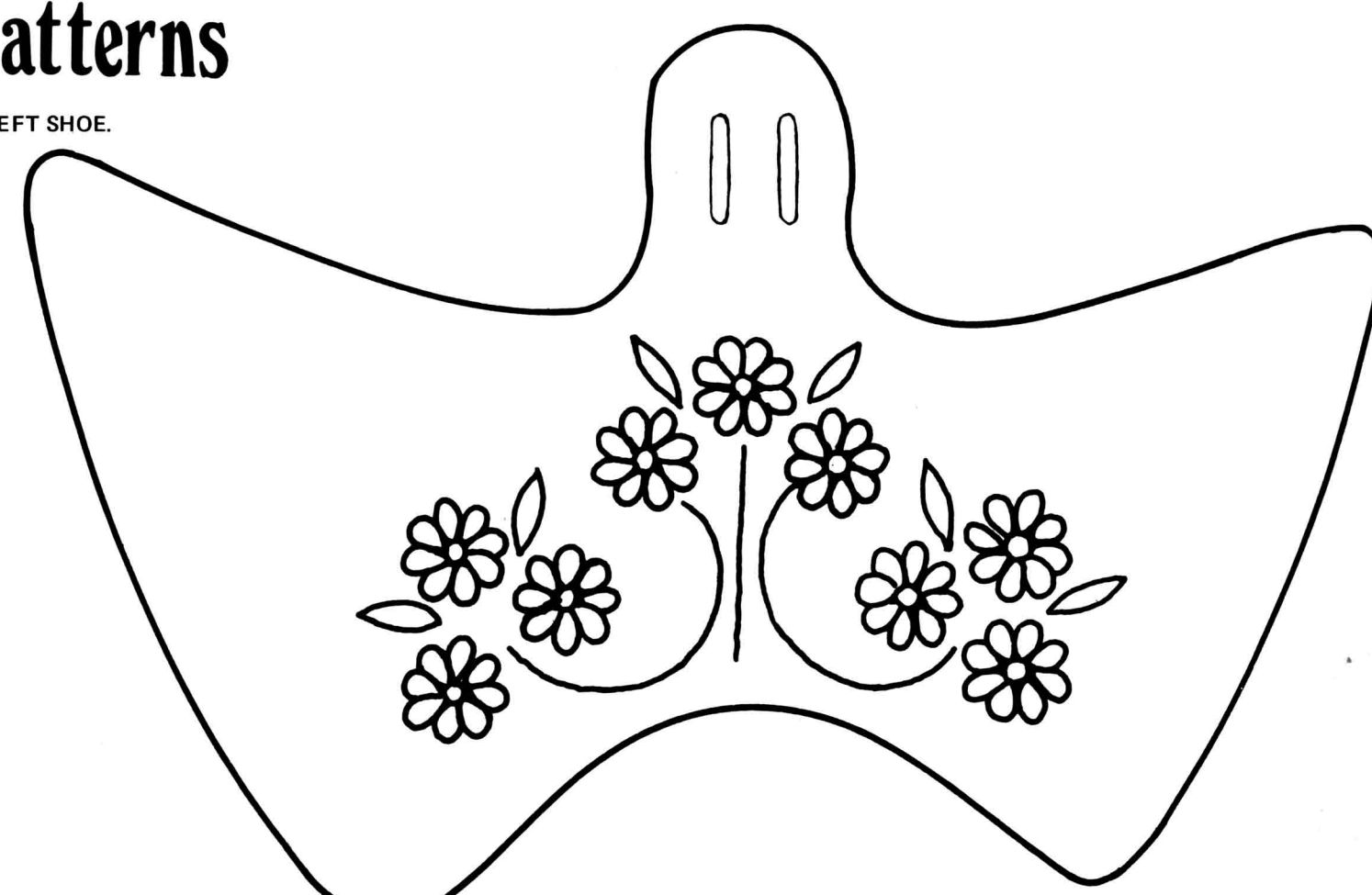
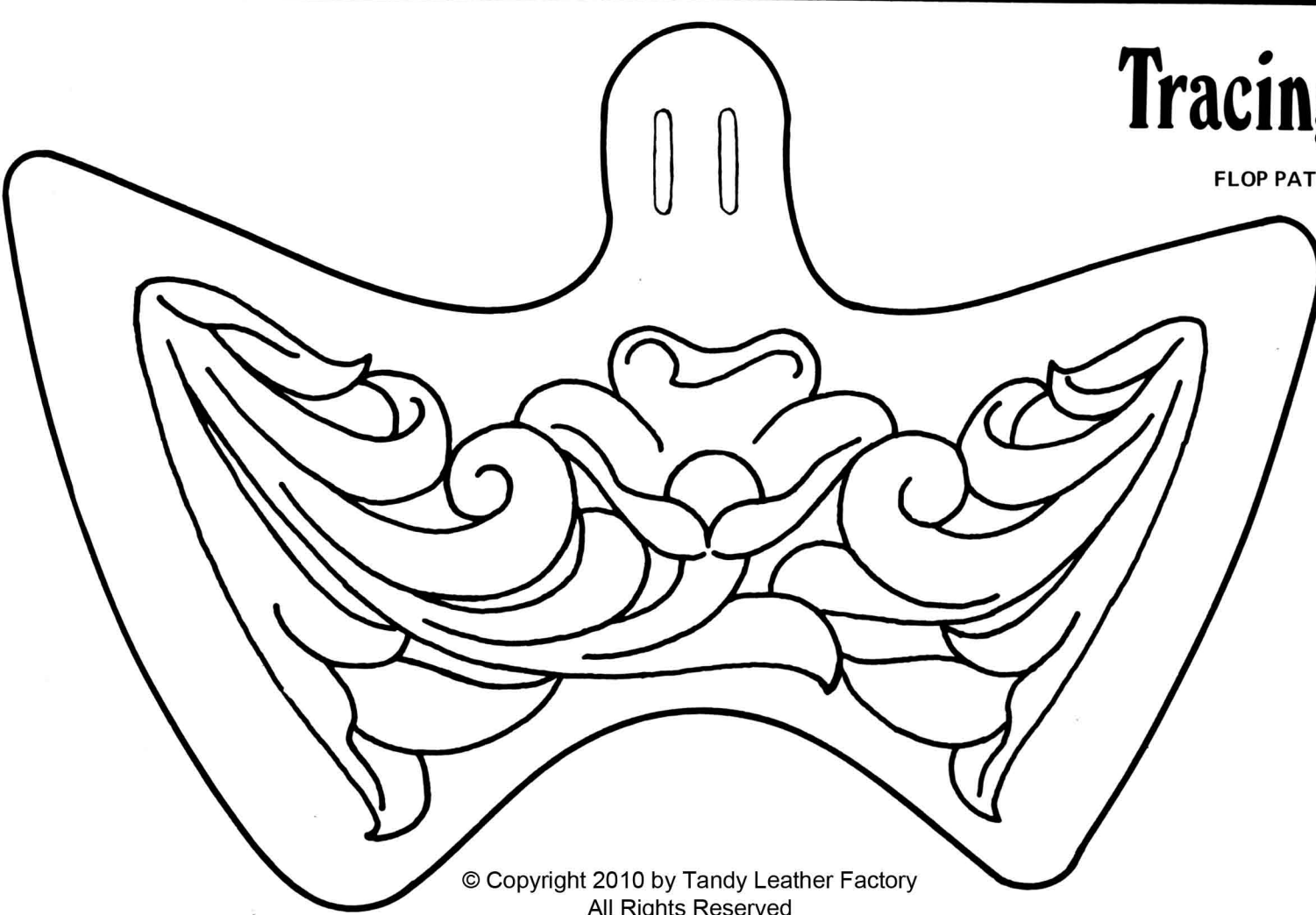



# Wedge Sandal Style



Distributed by Tandy Warehouse Co.,  
A Division of Tandy Leather Co.,  
Fort Worth, Texas

**KIT CONTAINS:**  
Nature-Tand Leather  
Tacks  
Buckles  
Medium Rapid Rivets  
Cutting and Pattern Sheets  
Assembly Instructions

**YOU WILL RECEIVE:**  
Craftsmen's  
Crafttools  
Knife  
Hammer  
Omega C  
Varnish  
8100 Rivets  
#3 Drive



# e D

## Pattern Parts

**NOTE:** Cut sole pieces from smaller piece of leather and cut all other pieces from largest piece of leather.

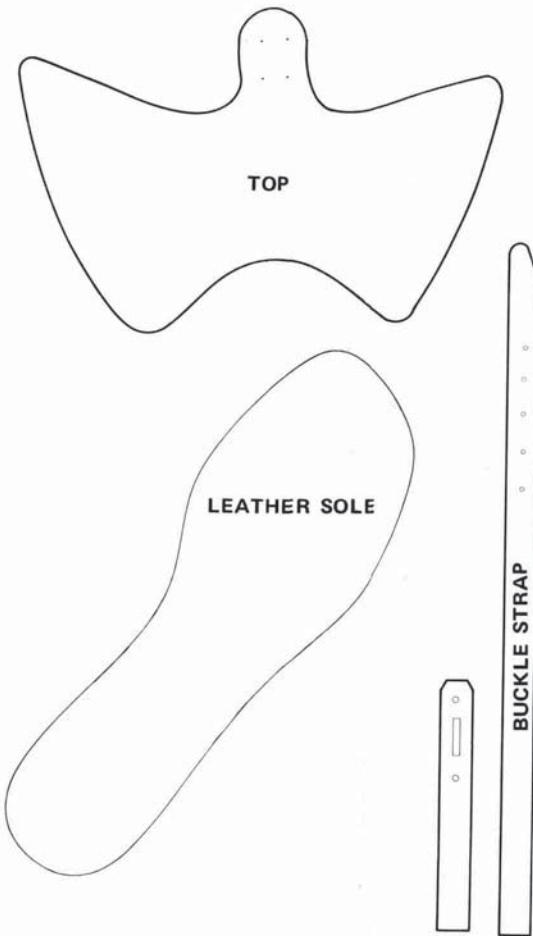

## Assembly Instruction

**NOTE:** Read through all assembly instructions beginning.

**SIZING:** After paper parts of pattern have been placed on your feet, in the proper positions; the pattern is large enough before cutting it out. This is especially important for the top piece, which must come down far enough on the wooden sole, with tacks. If you find your first selection is too small, the next largest size and trim the leather, as needed.

- ALL NEED:
- Thin Cement
- Scissors
- Leather
- Eye
- Eyelet Setter (Optional)
- Leather Punch



ns

ctions before

1 cut out, hold to insure each of the leather. e which must to be secured too short; use ded.

CUT 1 FOR RIGHT SANDAL  
(Flop pattern, CUT 1 for left sandal)

**Leather Sole**  
**Size 5**

**Leather Sole**  
**Size 6**



CUT 1 FOR RIGHT SANDAL  
(Flop pattern, CUT 1 for left sandal)

**Leather Sole**  
**Size 7**

CUT 1 FO  
(Flop pattern)

**Leat**  
**s**

**Leather Sole**

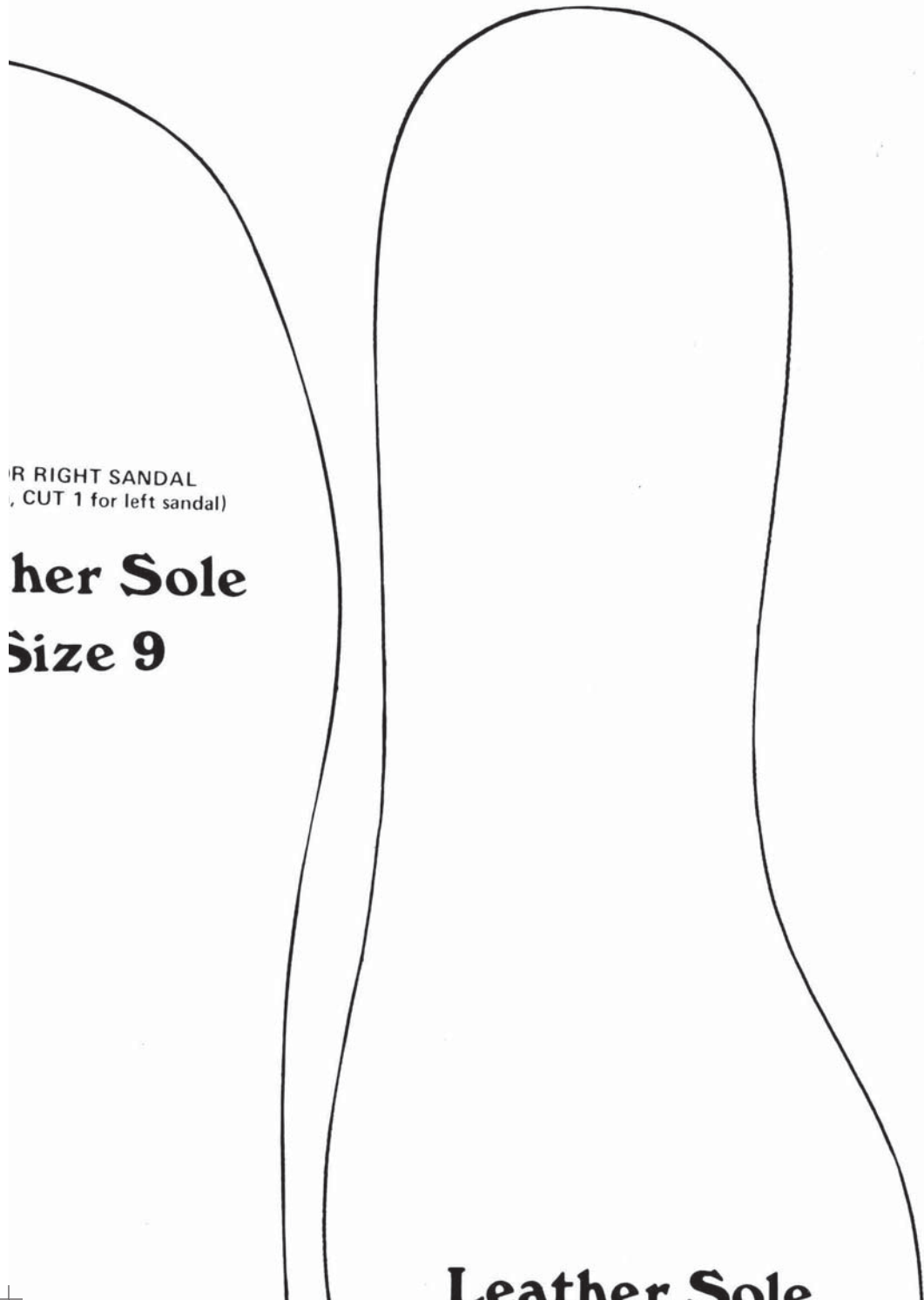

R RIGHT SANDAL  
(CUT 1 for left sandal)

**her Sole**  
**Size 9**

**Leather Sole**

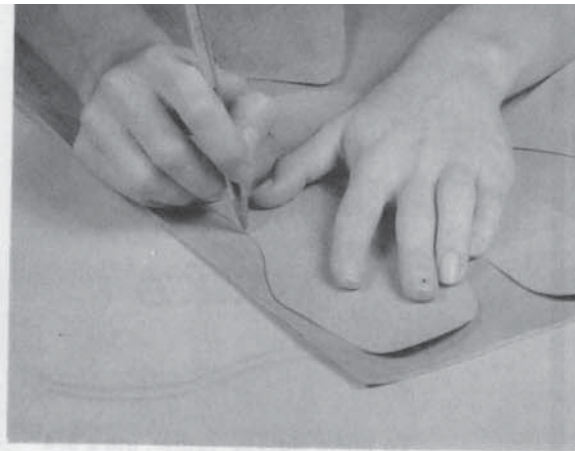

**STEP 1:** Select the correct size patterns (size indicated on wooden soles) to cut leather sole parts. Cut out the paper sole top and remaining parts with shears. Arrange all the pattern parts on grain side of leather and trace around them. (See photo.) To make both sole pieces, flop sole pattern and retrace.

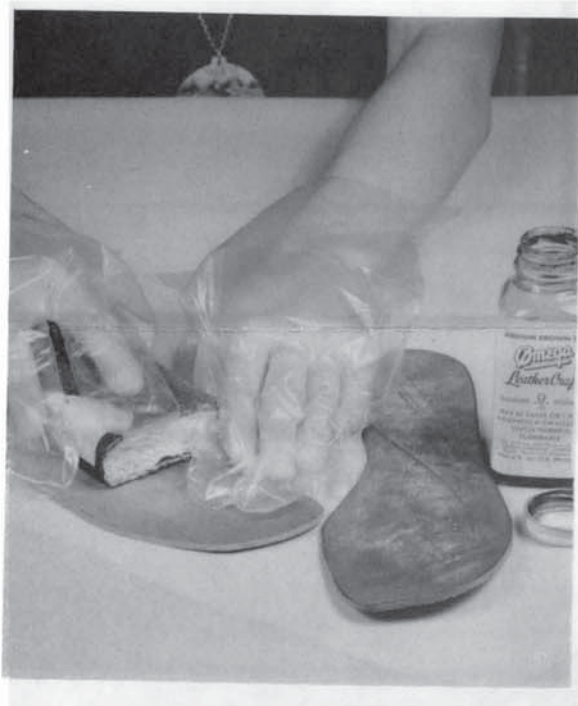

**NOTE:** Do all carving and stamping before dyeing (see photo-carve patterns).

**STEP 4:** Using Nature-Tand dyeing techniques on back of this sheet, dye the leather parts and then apply Carnauba Cream. Let dry and buff to a shine.



TI  
wi  
ST

STI  
sole  
to c

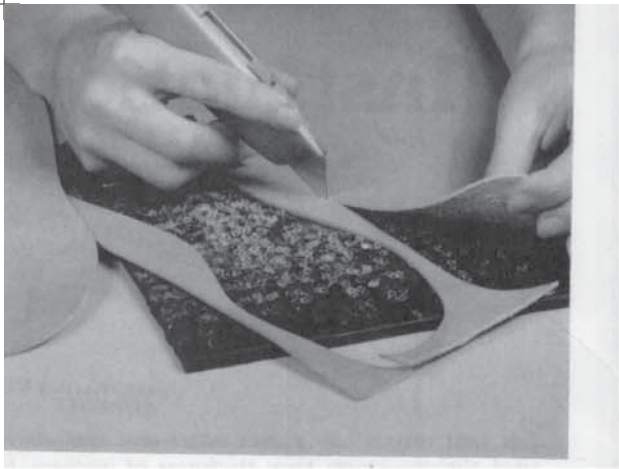

**RACING TIP:** Tracing the pieces of pattern on the leather will be easier if you make a set of cardboard patterns.

**STEP 2:** Cut along the traced lines with a sharp knife.

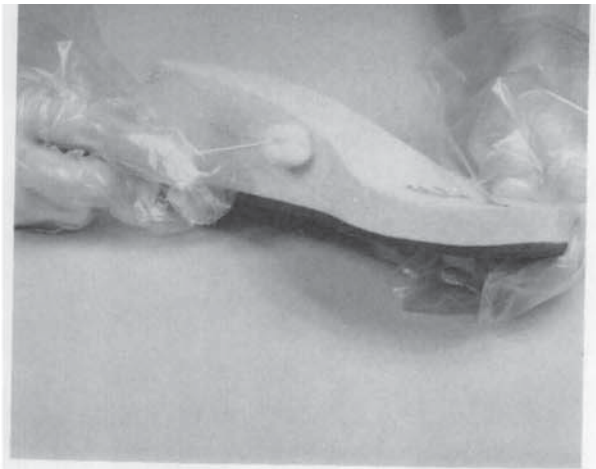

**STEP 3:** Stain and varnish, or just varnish the wooden soles.

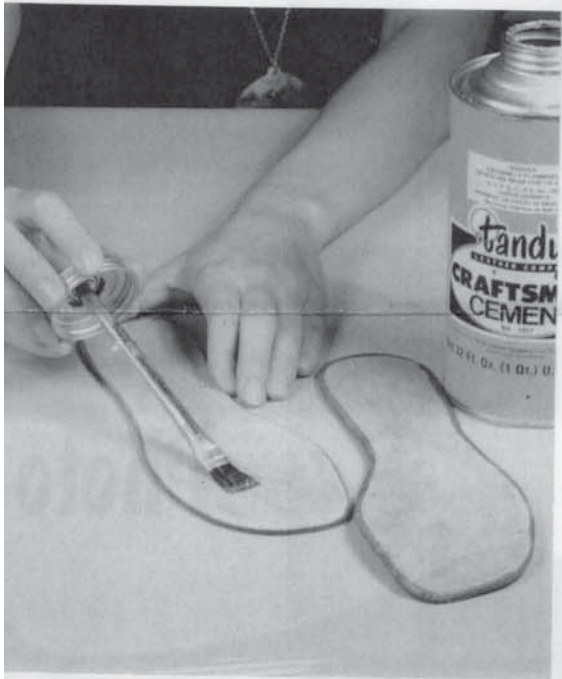

**STEP 5:** Apply Craftsman Cement to the top of the wooden soles and to flesh side of the leather soles. Allow the cement to dry until it becomes tacky.



**STEP 6:** Aligning edges; carefully press the toe of the leather sole to the toe of the wooden sole, with edges aligned at toe, work toward the heel. Press leather sole firmly in place. If leather extends off edge of wooden sole, trim with a sharp knife and carefully dye edges again. (Use small brush.)



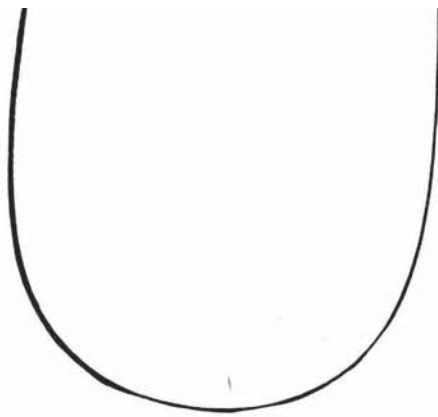

CUT 1 FOR RIGHT SANDAL  
(Flop pattern, CUT 1 for left sandal)

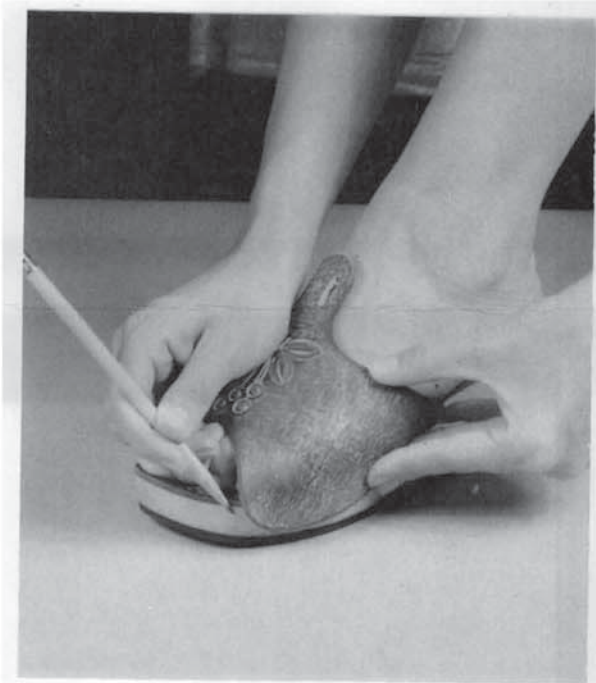

**STEP 7:** Place your foot on the sole and position leather top across top of foot, as shown. Mark wooden sole, lightly, with a pencil around edges of leather top for placement.

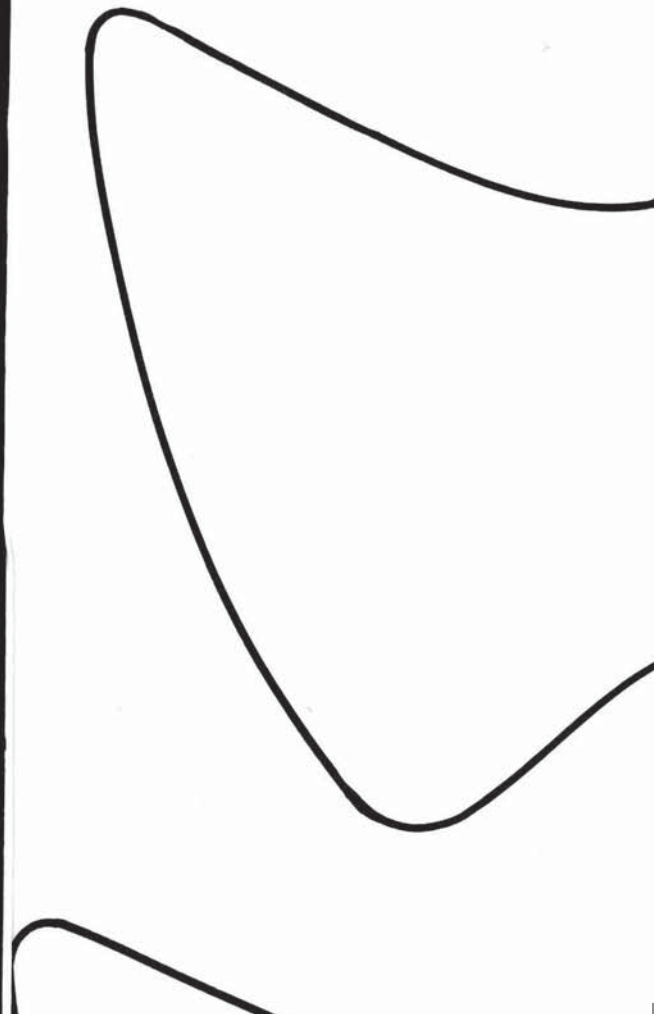



**Size 8**

CUT 1 FOR RIGHT SANDAL  
(Flop pattern, CUT 1 for left sandal)

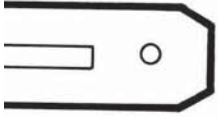

**Buckle Strap**



**Top  
Size 5**

CUT 1 FOR RIGHT  
(Flop pattern, CUT 1 for left)

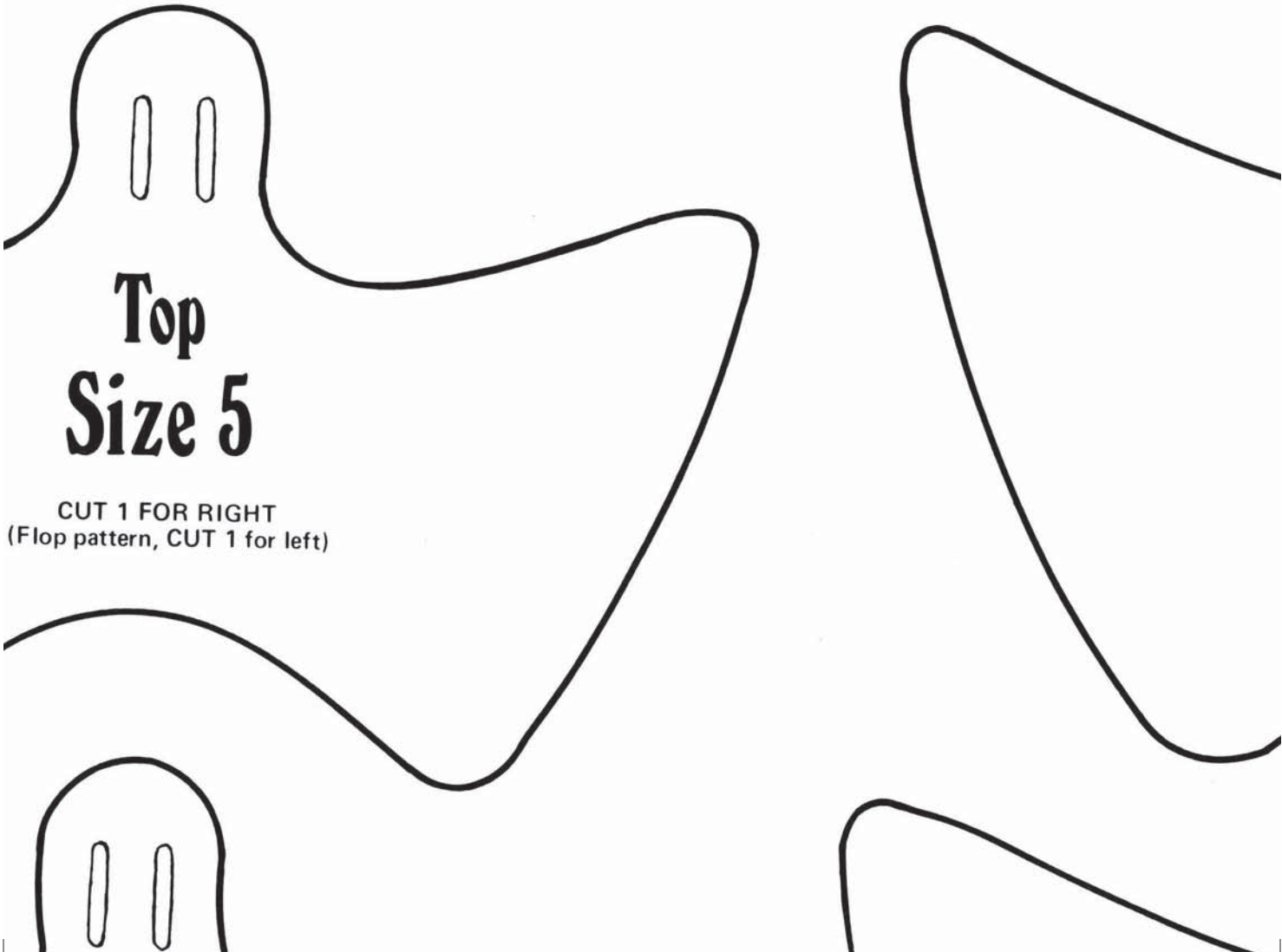

**LEATHER SOLE**

**Size 10**

CUT 1 FOR RIGHT SANDAL  
(Flop pattern, CUT 1 for left sandal)

**Top**  
**Size 6**

CUT 1 FOR RIGHT  
(Flop pattern, CUT 1 for left)

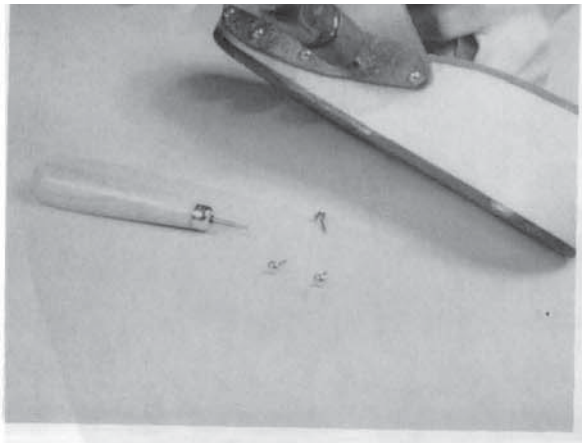

**STEP 8:** Nail leather top to wooden sole, as shown. You may wish to start hole in leather with awl, to hold nail while driving it in place. It's easier if you nail the ends first, center the middle tack, and then center the last two tacks between the end tacks and the center tack.

**STEP**  
buckl  
grain  
rivet

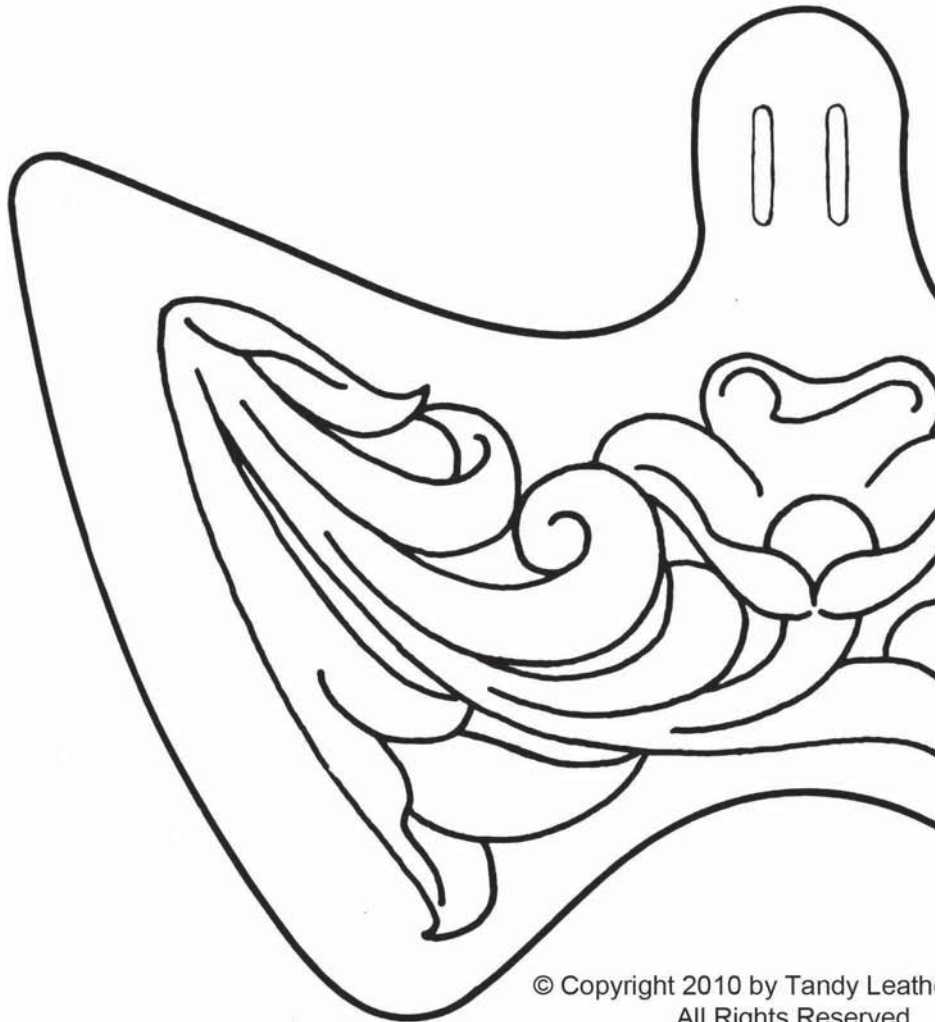

© Copyright 2010 by Tandy Leath  
All Rights Reserved

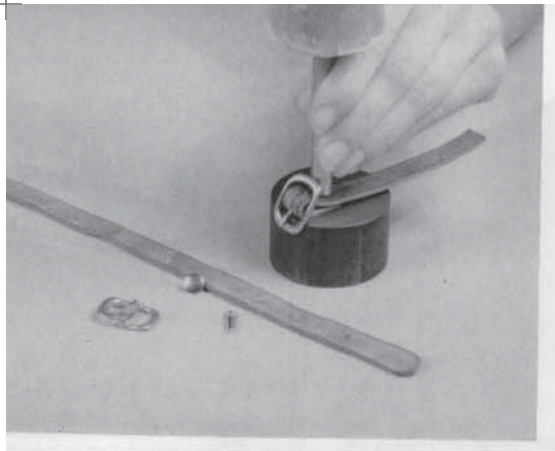

STEP 9: Insert buckle tongue through slit from grain side of the strap, fold buckle strap around buckle (grain side to side) and align rivet holes. Set rapid rivets using rapid instructions on reverse side of this sheet.



STEP 10: Attach top strap to buckle strap with buckle through the second hole to make one unit. Slip strap and buckle strap through slot in top piece. Position buckle on side of foot. Mark and cut off excess leather, dye edges. Then mark sole lightly, with a pencil at edges, for placement.

# Tracing Patterns

FLOP PATTERN FOR LEFT SHOE.

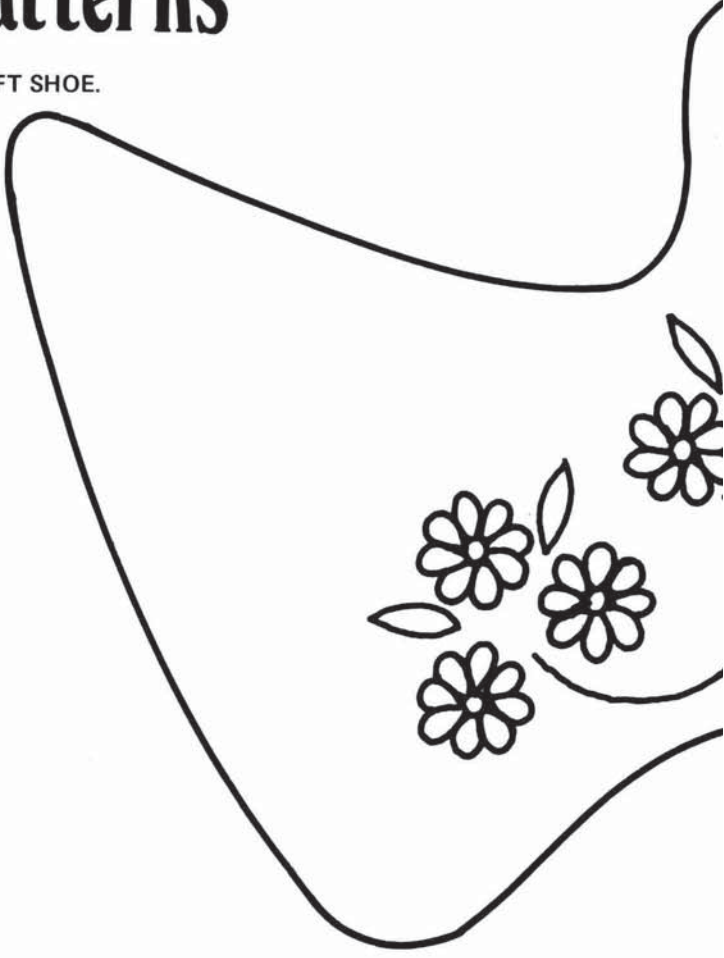
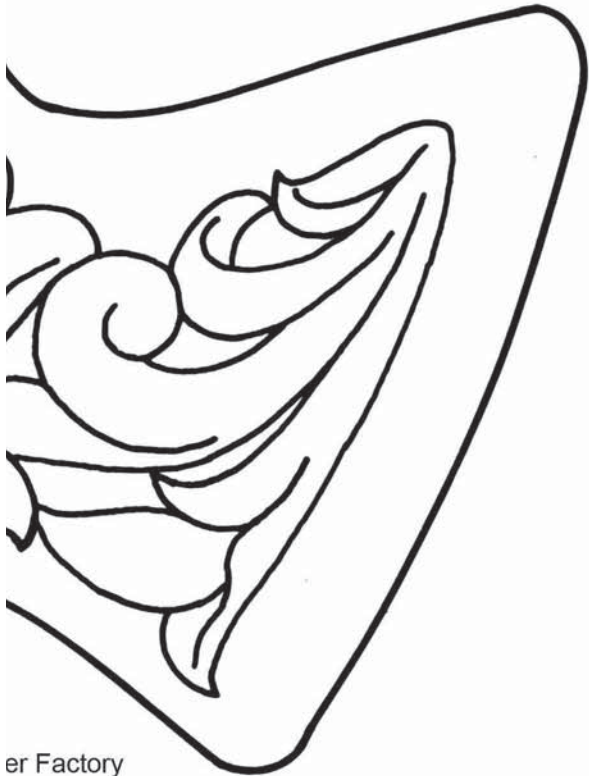

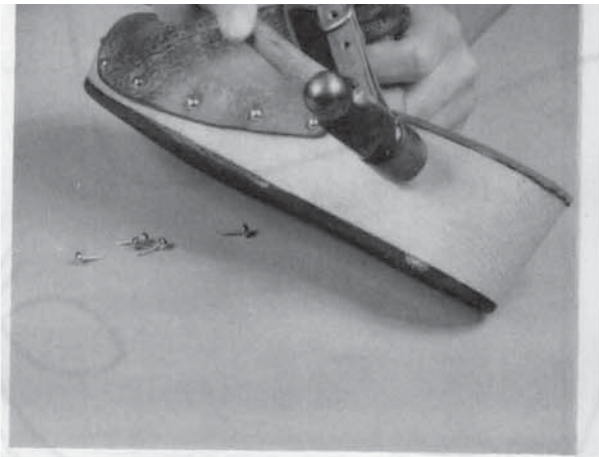

STEP 11: Nail strap in place.

(F

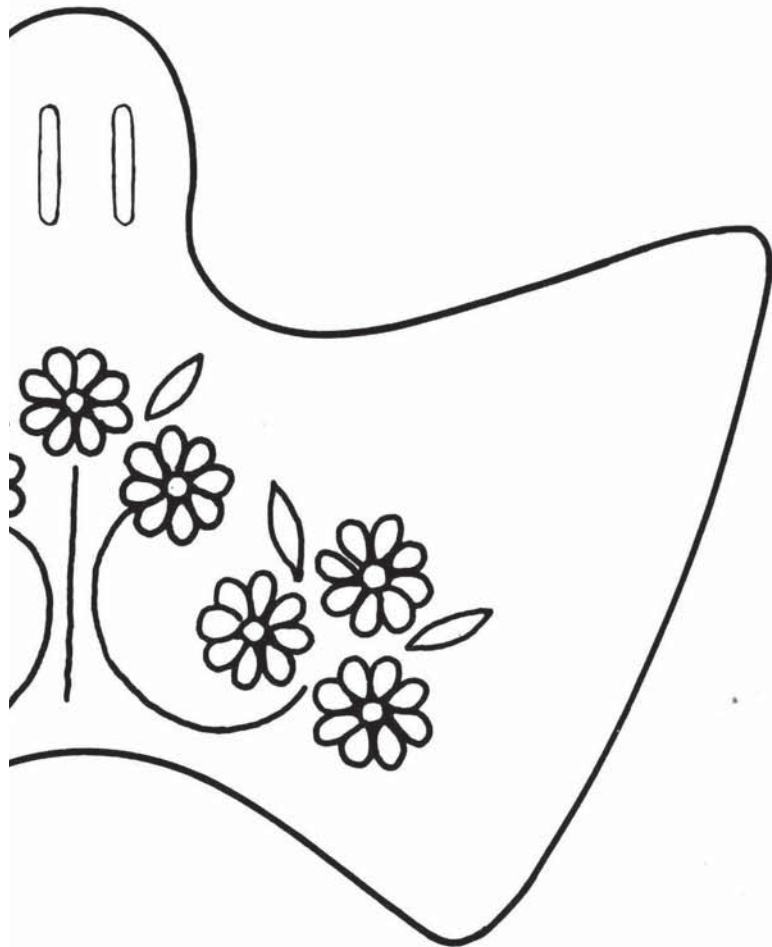

C  
(Flop

# Top Size 7

CUT 1 FOR RIGHT  
top pattern, CUT 1 for left)

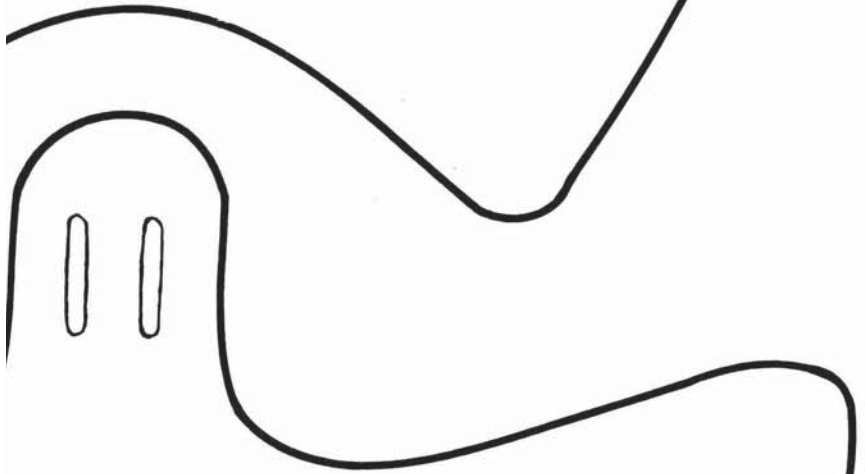

# Top Size 9

CUT 1 FOR RIGHT  
pattern, CUT 1 for left)

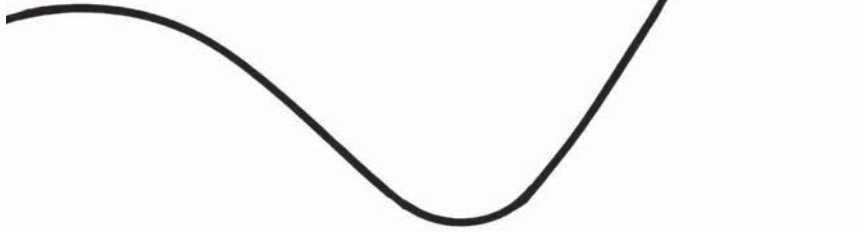

# Top Size 8

CUT 1 FOR RIGHT  
(Flop pattern, CUT 1 for left)

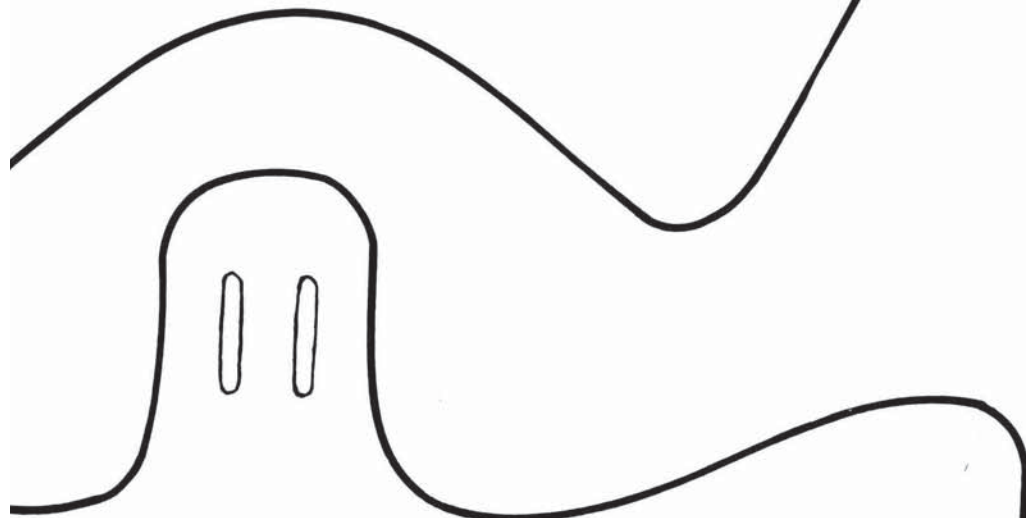

# Top Size 10

CUT 1 FOR RIGHT  
(Flop pattern, CUT 1 for left)

